



# PI

## Catalog

## Tap Position Indicator - PI

The Tap Position Indicator (PI) consists of a microprocessor based electronic device capable of monitoring and modifying, through the load tap changer (LTC), the positions of power transformer taps.

The PI incorporates the functions of several equipment gears that were used in past times for controlling the transformers LTC, such as selector switches Manual/Automatic and Local/Remote, manual control switch Raise/Lower and Tap Position Indicator, among others.

For this reason, the command wiring and the number of components are strongly reduced, raising substantially the general reliability and reducing the test and installation work time, besides that it greatly simplifies the maintenance.

The PI is even provided by signaling output contacts, indicating the tap position by current loop output, dry contacts input for remote command and serial port RS485, allowing complete data acquisition and total control of the LTC by distance.

The equipment was totally projected and tested for operating in the most unfavorable conditions found in electric substations, such as surges, impulses, electromagnetic interference and extreme temperatures.

## Main Features:

- Intelligent Tap Position Measurement: Automatic compensation of the interconnection cable resistance between potentiometric position transmitter and PI, allowing longer distances with smaller cables;
- Intelligent Tap Position Measurement: detection and alarming of bad electrical contact in the potentiometric position transmitter or in the interconnection cables;
- Indication of the LTC's position on display. Type of tap position indication is user-selectable: simple numeric (e.g. 1...33), bilateral numeric (e.g. -8...0...+8) or alphanumeric (e.g. 8L...N...8R);
- Number of positions set between 2 and 50. Programmable resistance values meets all types of LTC. Optional mA current input for position measurement.
- Local/Remote selection made directly on the front panel or through external dry contacts.
- Manual/Automatic operation mode selection made directly on the front panel or through external dry contacts.
- Manual Raise/Lower commands made directly on the front panel or through external dry contacts.
- Current loop output enables the remote indication and/or monitoring of the LTC's position. Output range selectable by user at front panel: 0...1, -1...+1, 0...5, -5...+5, 0...10, -10...+10, 0...20, -20...+20 or 4...20 mA;
- Four output relays to indicate status and/or alarms.
- All parameters can be configured through the PI's front panel or through the RS-485 communication port. All selections and commands can be performed also through the RS-485 with protocols Modbus RTU (standard) or DNP3.0 (using optional module COMM-04).
- Self-diagnosis: two micro-controllers with reciprocal supervision for detection of failures. Total absence of mechanical parts for parameter definition and calibration.

## Technical Data

Condition	Interval / Description
<b>Power Supply:</b>	38 to 265 Vdc/Vac 50/60Hz
<b>Consumption:</b>	< 5 W
<b>Operation Temperature:</b>	-10 to +70 °C
<b>Degree of Protection:</b>	IP 20
<b>Wire Size - removable connections:</b>	0,3 to 2,5mm <sup>2</sup> , 22 to 12 AWG
<b>Fixation:</b>	Built-in in panel
<b>Tap Measurement input:</b>	Potentiometric 3 wires or Current mA
<b>Number of Taps of the LTC:</b>	2 to 50
<b>Total resistance of the potentiometric transmitter:</b>	9,4 to 1000W
<b>Resistance by step of the potentiometric transmitter:</b>	4.7 to 20W (resistors precision 1% or better)
<b>Current Input (selectable):</b>	0...1mA 0...5mA 0...10mA 0...20mA 4...20mA
<b>Analog Output Options and Maximum Load:</b>	0 ... 1 mA - 12000W 0 ... 5 mA - 2400W 0 ... 10 mA - 1200W 0 ... 20 mA - 600W 4 ... 20mA - 600W -1 ... +1mA - 12000W -5 ... +5mA - 2400W -10 ... +10mA - 1200W -20 ... +20mA - 600W
<b>Maximum error of the Analog Output:</b>	0.5% of full scale
<b>Output Contacts:</b>	Free of potential
<b>Maximum Switching Power:</b>	70 W (dc) / 250 VA (ac)
<b>Maximum Switching Voltage:</b>	250 Vdc/Vac
<b>Maximum Conduction Current:</b>	2,0 A
<b>Serial communication portal:</b>	1 (one) RS485
<b>Communication Protocol with the Supervisor System:</b>	Modbus RTU slave (standard) DNP3.0 level 1 (using optional communication module COMM-04)

## Connection Diagram

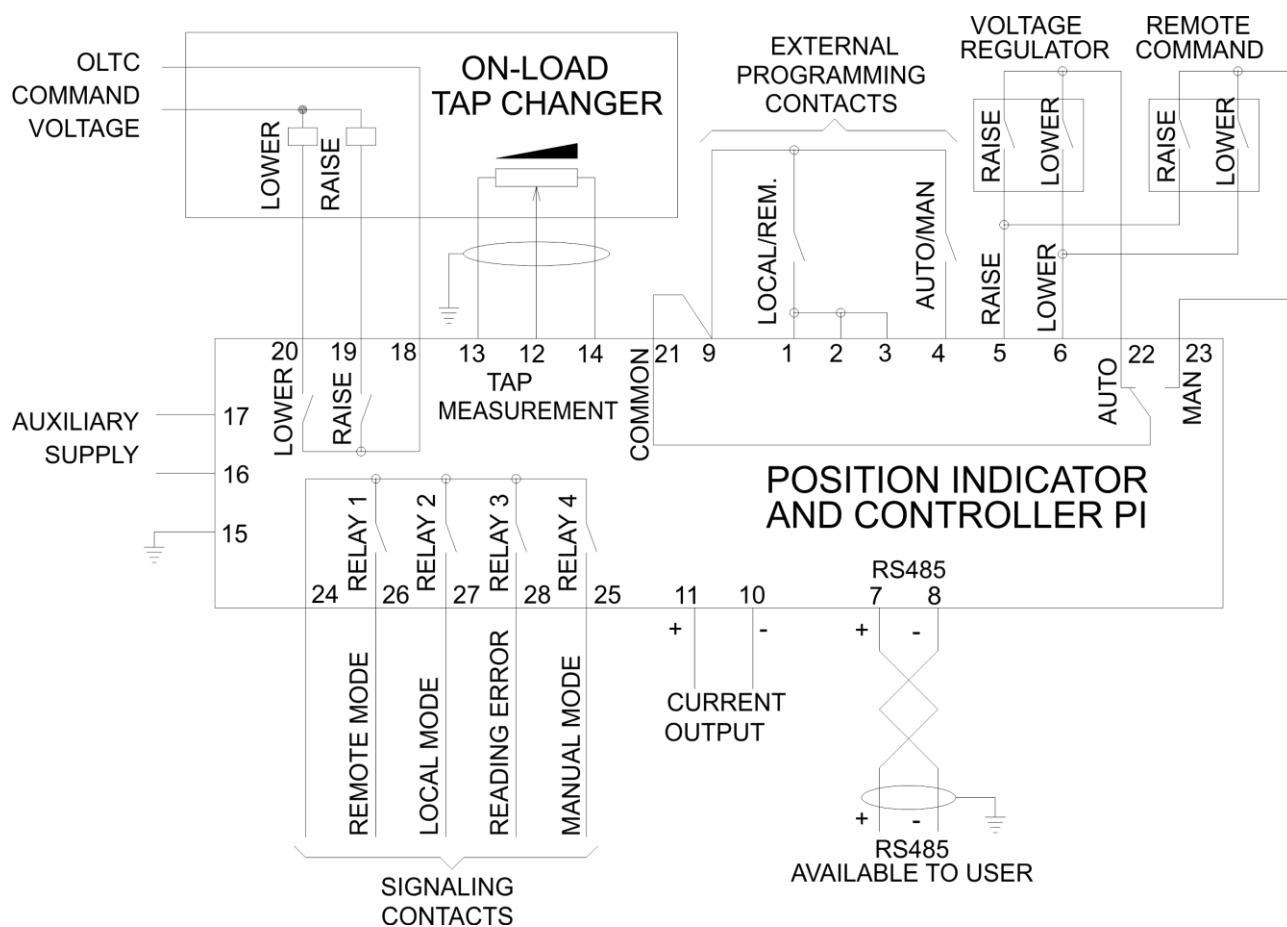

a) Potentiometric input (default)

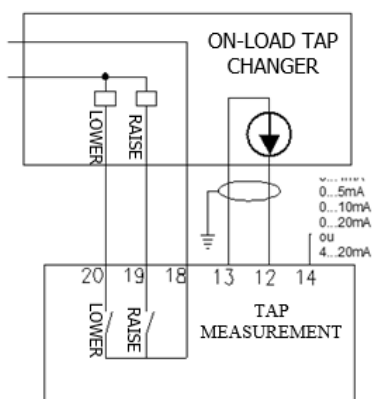

b) Current loop input  
0...5 / 0...10 / 0...20 / 4...20 mA

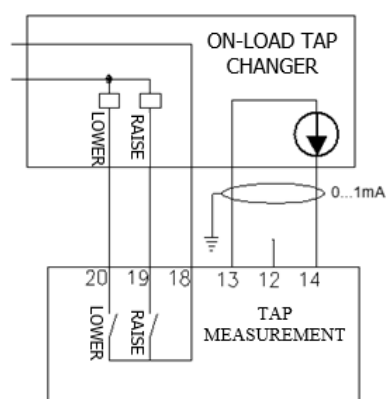

c) Current loop input  
0...1 mA

### Notes:

- 1) The resistors in the Load Tap Changer for remote position indication must have 1% precision or better.
- 2) All contacts shown with PI de-energized.

## Dimensions

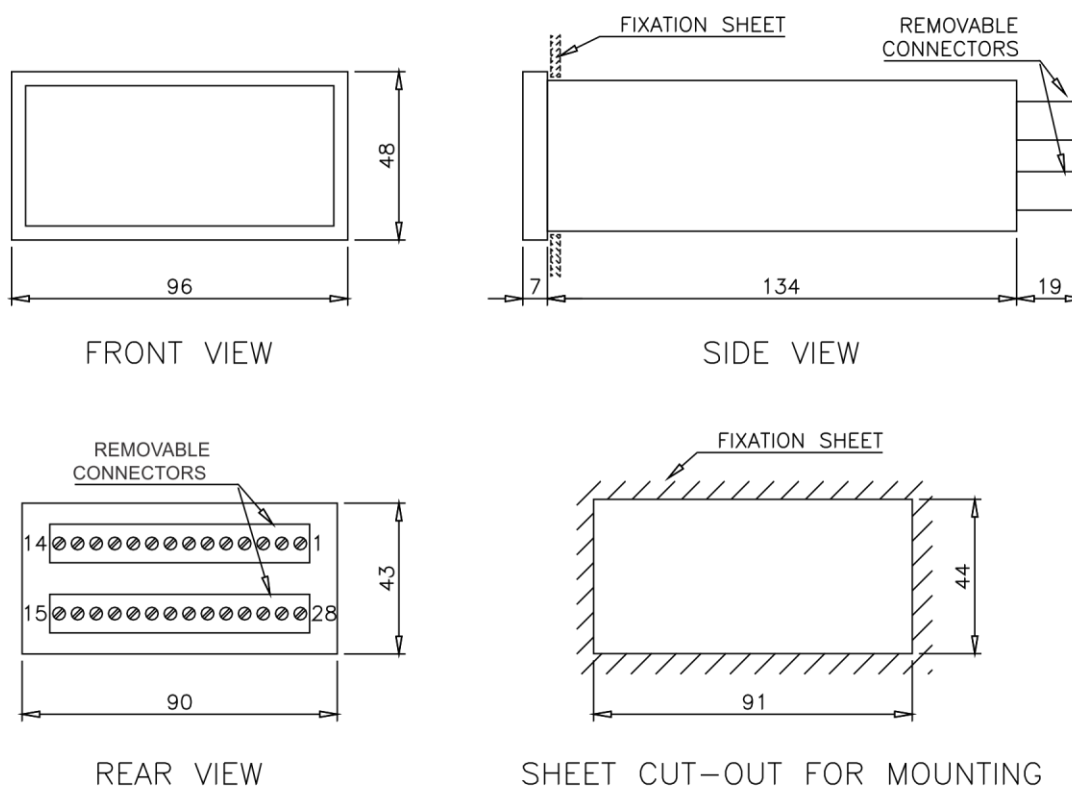

ALL DIMENSIONS IN mm

## Order Specification

The Tap Position Indicators PI are universal devices. The PI features are selected by using the programming menus. These adjustments can be made directly on the device's front panel or by way of the serial communication port RS485. The power feed input is universal (38 to 265 Vdc/Vac 50/60Hz).

Therefore, in purchase orders for the equipment only the following need to be informed:

- Tap Position Indicator PI
  - Type of tap measurement input:
    - Standard - Potentiometric input (Resistive input) - inform the code PI;
    - Optional - Current mA input - inform the code PI-I
  - Quantity.
- Optional accessories needed.

## Optional Accessories

### **Communication Module COMM-04 with Protocol DNP3.0**

Used together with the Position Indicator PI, the communication module COMM-04 with protocol DNP3.0 allows for every measurements, status, selections and tap changer control to be performed remotely using this protocol. The COMM-04 module must be specified with the optional DNP3.0 protocol.

## Type Testing

<b>Surge Immunity (IEC 61000-4-5):</b>	
<b>phase-neutral surges:</b>	1 kV, 5 per polarity (+/-)
<b>phase-ground and neutral-ground surges:</b>	2 kV, 5 per polarity (+/-)
<b>Electrical transients Immunity (IEC 60255-22-1):</b>	
<b>1st cycle peak:</b>	2.5 kV
<b>frequency:</b>	1.1 MHz
<b>time and repetition rate:</b>	2 seconds, 400 surges/sec.
<b>decay to 50%:</b>	5 cycles
<b>Voltage Impulse (IEC 60255-5):</b>	
<b>Wave form:</b>	1,2 / 50 ms
<b>Amplitude and energy:</b>	5kV, 0.5J
<b>Number of pulses:</b>	3 negative e 3 positive, 5s interval
<b>Insulation Voltage (IEC 60255-5):</b>	
<b>Industrial frequency insulation voltage:</b>	2 kV 60Hz 1 min. to ground
<b>Irradiated electromagnetic field Immunity (IEC 61000-4-3):</b>	
<b>Frequency:</b>	26 to 1000 MHz
<b>Field intensity:</b>	10 V/m
<b>Conduced electromagnetic perturbations immunity IEC 61000-4-6):</b>	
<b>Frequency:</b>	0.15 to 80 MHz
<b>Field intensity:</b>	10 V/m
<b>Electrostatic Discharge (IEC 60255-22-2):</b>	
<b>Air mode:</b>	8 kV, ten discharges per polarity
<b>Contact mode:</b>	6 kV, ten discharges per polarity
<b>Fast electrical transient immunity (IEC61000-4-4):</b>	
<b>Power supply, inputs and outputs:</b>	6 kV, ten discharges per polarity
<b>Serial communication port:</b>	2 kV
<b>Climatic test: (IEC 60068-2-14):</b>	
<b>Temperature range:</b>	-40 to +85°C
<b>Total test time:</b>	96 hours
<b>Vibration response: (IEC 60255-21-1):</b>	
<b>Application mode:</b>	3 axis (X, Y e Z), sinusoidal
<b>Amplitude:</b>	0,075mm from 10 to 58 Hz
<b>Duration:</b>	1G from 58 to 150 Hz
<b>Duration:</b>	8 min/axis
<b>Vibration resistance: (IEC 60255-21-1):</b>	
<b>Application mode:</b>	3 axis (X, Y e Z), sinusoidal
<b>Frequency:</b>	10 to 150 Hz
<b>Amplitude:</b>	2G
<b>Duration:</b>	160 min/axis



# Treetech

Treetech Tecnologia  
Rua José Alvim, 112, Centro  
CEP 12940-750 - Atibaia/SP  
+ 55 11 2410-1190

[www.treetech.com.br](http://www.treetech.com.br)