

TAP POSITION INDICATOR AND CONTROLLER

The logo consists of the letters 'PI' in a bold, black, sans-serif font, centered within a solid green square.

FOR TRANSFORMERS WITH ON-LOAD TAP CHANGER

Technical Manual

Index

Section	Title	Page
	Security and Warranty	ii
I	Operation Philosophy	I – 1
II	Operation	II – 1
III	Project and Installation	III – 1
IV	Start-up	IV – 1
V	Troubleshooting	V – 1
VI	Appendixes	VI – 1

Note: There is a detailed index of each section in the beginning of them.

SECURITY AND WARRANTY

This manual must be available for technicians responsible for the installation and for Position Indicators (PI) users.

The Position Indicator and Controller (PI) installation and operation generally does not offer danger for the operators, however the power transformers operation requests special caution and all the applicable standards, safety proceedings, safe working practice and good sense must be used during the equipment installation, operation and maintenance.

WARNING

To assure users safety, equipment protection and correct operation, the following cautions must be taken during the PI installation, operation and maintenance:

- 1) Read this manual carefully before the PI installation, operation and maintenance. Faults happened during the installation and adjustments can cause unsafe operation, implicating risks to the equipment, damage and undue trip of the transformer.

- 2) Instructed people who are proficient with control device and power transformers command circuits must do the PI installation, adjustments and operation.
- 3) Special attention must be taken to the PI installation (see Section III), including the type and size of the cables used, even as to the procedure during the start-up (Section IV), including the equipment parameterization.

TERM OF WARRANTY

The Tap Position Indicator and Controller PI shall be warranted by Treotech during 2 (two) years, counting from the acquisition date, exclusively for instances of eventual manufacture defects or quality flaws that can turn the equipment incapable to regular usage.

The warranty does not include damages caused to the product, upon accidents, maltreatment, improper handling, improper installation and application, improper testing and disruption of the warranty label.

The eventual requirement of technical assistance must be reported to TREETECH, or to a technical assistance designated by TREETECH.

None warranty, expressed or implied, further those mentioned above are provided by Treotech. Treotech does not provide any warranty of PI adequacy for a particular application.

The seller shall not be liable for any property damages whatsoever or for any loss or damage arising out of, connected with, or resulting from this contract, or from the performance or breach thereof, or from all services possibly furnished together with the equipment.

In no event shall the seller be liable for special, incidental, exemplary, or consequential damages, including but not limited to, loss of profits or revenue, loss of use of the equipment or any associated equipment, cost of capital, cost of purchased power, cost of substitute equipment, facilities or services, downtime costs, or claims or damages of customers or employees of the Buyer for such damages, regardless of whether said claim or damages is based on contract, warranty, tort including negligence, or otherwise.

Under no circumstance shall the Seller be liable for any personal injury whatsoever.

Section I – Operation Philosophy

Index of Subjects

Chapter	Title	Page
1	Introduction	I - 2
2	Basic Operation Philosophy	I - 2
2.1	Manual/Automatic Command Modes	I - 3
2.2	Local/Remote Command Modes	I - 3

Index of Pictures

Picture	Title	Page
1.1	Tap Position Indication and Controller PI	I - 2

1. Introduction

The Tap Position Indicator and Controller PI is a device developed by Treotech to control and to supervise the operation of on-load tap changers (OLTC) in power transformers.

Based on microcontrollers, the PI incorporates the functions of several equipment gears that were used in past times for controlling the OLTC, such as selector switches Manual/Automatic and Local/Remote, control switches for Raise/Lower manual commands and tap position indicators, among others. For this reason, the command wiring and the number of components are reduced, raising substantially the general reliability and reducing the tests and installation work time, besides that it greatly simplifies the equipment maintenance.

The PI is even provided by signaling output contacts, indication of tap position by current loop output, dry contacts input for remote command and serial port RS485, allowing complete data acquisition and total control of the OLTC by distance.

The equipment was totally projected and tested for operating in the most unfavorable conditions found in electric substations, such as surges, impulses, electromagnetic interference and extreme temperatures.



Figure 1.1 – Tap Position Indicator and Controller PI

2. Basic Operation Philosophy

In general, on-load tap changers (OLTC) are used in power transformers with the objective of allowing the regulation of secondary voltage to the loads without interruption in electrical energy supply. By changing the OLTC position it is possible to raise or lower the transformer secondary voltage. The total number of positions in the tap changer can vary according to the application needs.

2.1 Manual/Automatic Command Modes

Regarding to the type of raise/lower commands for the OLTCs, there are two possibilities: Manual Command or Automatic Command. By selecting the Manual Command mode, the tap changes occur only when requested by the operator, while the Automatic Mode enables the raise/lower tap commands sent by an Automatic Voltage Regulator Relay (relay 90).

2.2 Local/Remote Command Modes

Regarding to the local from where can be performed the selections Automatic/Manual and the commands raise/lower tap, there are three possibilities:

- a) Local Command, by the PI front keypad;
- b) Remote Command, by external dry contacts connected to the PI;

c) Remote Command, by the serial communication RS485, from a supervisor system.

If the Local Command is selected, both of the remote command modes remain blocked (in case of serial communication, only the information acquisition is possible). If the Remote command were selected, the system operation by the front keyboard remains blocked, liberating both of the remote command modes. In general, only one of the both remote command options is used, because one eliminates other's necessity. It is possible, however, to have both remote modes operating simultaneously.

Section II – Operation

Index of Subjects

Chapter	Title	Page
3	Local Operation of the PI	II – 2
3.1	Primary indications in the display	II – 2
3.2	Local/Remote and Manual/Automatic Selections	II – 3
3.3	Raise/Lower Tap manual command	II – 4
3.4	Error Conditions Alarms	II – 5
3.4.1	Tap Position Reading Error (E08)	II – 5
3.5	System Operation during error conditions	II – 7
3.5.1	E08 - Tap Position Reading Error	II – 7

Index of Pictures

Picture	Title	Page
3.1	Indication of the tap changer current position	II - 3
3.2	Indication during a change of position in progress	II - 3
3.3	Indication during an error condition occurrence	II - 4

3. Local Operation of PI

The local operation of the PI is done by its front panel, using the P, ↑ and ↓ keys, with the support of the equipment display.

3.1 Primary indications in the display

During the system autonomous operation, without the operator intervention by the front keys, the PI display can accomplish one of the following indications:

- a) Current position of the on-load tap changer associated to it. The display indicates permanently this information, which can be shown by simple numeric, bilateral numeric or alphanumeric formats (for example: 1...17, -8...0...+8 or 8L...N...8R respectively). See picture 3.1;



Picture 3.1 – Indication of the tap changer current position

- b) Intermittent indication of the tap changer current position and indication of the symbols ↑↑↑ or ↓↓↓, if a tap change is in progress to raise or lower

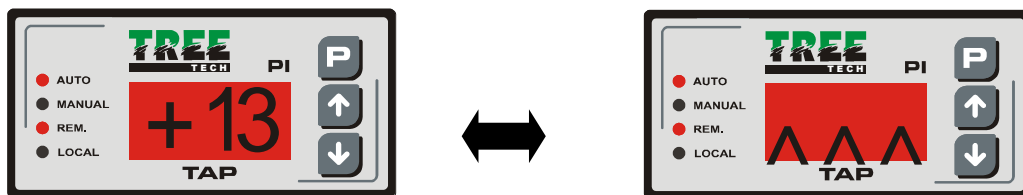

tap respectively. See picture 3.2;

Picture 3.2 – Indication during a change of a position in progress

- c) Intermittent indication of the tap changer current position and an error code. The description of the possible error conditions and the associated codes can be verified in the item 3.6. See picture 3.3.

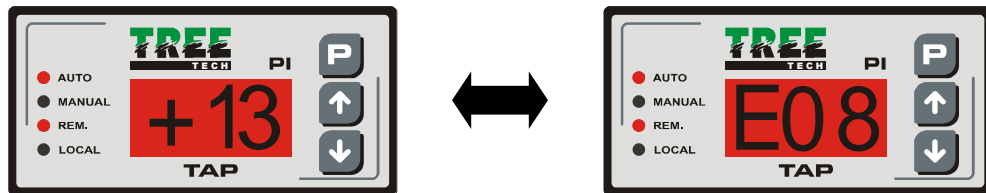











Picture 3.3 – Indication during an error condition occurrence

During the operator interventions by the front keyboard, the indications in the display are the following described in the item 3.2.



3.2 Local/Remote and Manual/Automatic Selections

The Local/Remote and Manual/Automatic selections can be operated in local manner, by the SPS front keyboard, as described below.

Procedure	Effect	Preview
Press Key P for a moment.	It is accessed the first programming menu, with the Local/Remote selection. The current status of this selection is displayed respectively by LOC or REM codes.	 <p style="text-align: center;">OR</p> 
Press ↑ or ↓ keys for a moment.	The selection is changed from Local to Remote or vice versa.	 <p style="text-align: center;">↕</p> 
Procedure	Effect	Preview
Press Key P for a moment	<p>If during the previous step the Remote mode was selected, the PI exists the programming menu, returning to the condition described in 3.1</p> <p>If during the previous step the Local mode was selected, it is accessed the second programming menu, with Manual/Automatic selection. The current status of this selection is displayed respectively by MAN or AUT codes.</p>	 <p style="text-align: center;">OR</p>  <p style="text-align: center;">OR</p> 
Press ↑ or ↓ keys for a moment	The selection is changed from Manual to Automatic or vice versa.	 <p style="text-align: center;">↕</p> 
Press Key P for a moment	The PI exits the programming menu, returning to the condition described in 3.1	

3.3 Raise/Lower Tap manual command

The manual command to Raise and Low the position of the on-load tap changer can be operated in local manner, using the ↑ and ↓ keys of the PI front, as described below. These commands will only be followed if a previous selection of the Local and Manual command modes is done.

Procedure	Effect	Preview
Press ↑ or ↓ keys for a moment	If the Remote mode were previously selected, the display will show the REM message during 1 second, indicating that the command will not be followed, because the PI is selected in this mode.	
	If the Local and Manual command modes are selected, the corresponding command will be sent to the on-load tap changer, and it will be displayed that the tap change is in progress by the periodical indication of the ↑↑↑ or ↓↓↓ symbols on the display.	 Or 

3.4 Error Conditions Alarms

The alarm conditions of the PI are signalized in the front display by the error codes listed below, besides that it allows its remote signaling by output contacts, as described in sub-chapter 5.6.

All the error indications are automatically restarted, that is, the indication displayed disappears when the error condition is eliminated, the same occurs with the corresponding signaling contact, which returns to its repose condition.

Code	Error Condition
E08	Tap position reading error

3.4.1 Tap Position Reading Error (E08)

It is caused by a reading fail of the current tap position of the load tap changer. It is detected by the following reading consistency verifications. For each one of these verifications is applied an error cause code, that is stored for posterior verification by the maintenance staff.

- a) Internal Error in the communication between the tap reading microcontroller and the principal microcontroller. This reading error cause is stored as the "C1" code,
- b) Unstable tap position reading, in other words, floating much more fast than what would be possible for the normal operation of the load tap changer. This reading error cause is stored as the "C2" code,
- c) Inconsistency in the tap position calculated from the several resistance measurements accomplished in the potentiometric transmitter of the tap changer. This reading error cause is stored as the "C3" code.

Without putting away another possibilities that can be verified, the possible causes for this error are:

- Excessive electromagnetic interference in the measurement cables of the potentiometric position transmitter, due to the usage of non-shielded cables (C2 cause);
- Excessive electromagnetic interference due to the lack of grounding of the measurement cables shield of the potentiometric position transmitter (C2 cause);
- Excessive Electromagnetic interference due to the grounding of the measurement cables shield of the potentiometric position transmitter in more than one point, enabling the current circulation by the shield due to the ground potential differences (C2 cause);

- Poor contact in the cursor of the potentiometric position transmitter or in the connection cables from this one to the PI (C3 cause);
- Connection cables from the potentiometric position transmitter to the PI with resistance superior to 8Ω per wire - very reduced size due to the roaming distance (C3 cause);
- Connection cables from the potentiometric position transmitter to the PI with different sizes or with different lengths in each wire (C3 cause);
- Defect in the PI tap measurement circuit (C1 cause).

3.5 System Operation during errors presence

An ideal proceeding during any error occurrence is, naturally, detecting and correcting its cause before continue the operation of the system.

However, when this proceeding is not possible to be done, or when there is no time left to the problem correction, due to the prompt necessity of the system operation, some emergency proceedings can be used, as suggested bellow. It must be taken all cares related to the indicated Special Cautions, to prevent conditions with risk of transformer trip by the protection operation or even with risk to the transformer integrity.

3.5.1 E08 – Tap Reading Error

Error condition and its Local	<ul style="list-style-type: none"> • E08 (tap reading error)
Contingency Procedure	<ul style="list-style-type: none"> • The transformer that contains error can only be operated from the on-load tap changer, as it is not possible to know by the PI what is the real tap position of the tap changer.
Special Cautions	<ul style="list-style-type: none"> • Use the mechanical position indicator in the OLTC motor cabinet for checking of the raise/lower commands performed.

Section III – Project and Installation

Index of Subjects

Chapter	Title	Page
4	Topology for PI application	III – 3
5	Inputs and Outputs	III – 5
5.1	Auxiliary power and ground	III – 5
5.2	Tap changer position measurement	III – 5
5.2.1	Connection cables for tap measurement	III – 5
5.2.2	Requirements for the tap position transmitter	III – 7
5.3	Analog output of tap changer position	III – 8
5.4	Raise/Lower Tap output Contacts	III – 9
5.5	Contact inputs for Remote Programming/Command	III – 10
5.5.1	Local/Remote programming input	III – 11
5.5.2	Manual/Automatic programming input	III – 11
5.5.3	Raise/Lower Tap command Inputs	III – 12
5.6	Output Relays for Signaling	III – 13
5.7	Serial communication RS485	III – 14
6	Connection diagrams	III – 14
7	Mechanical Installation	III – 15

Index of Pictures

Picture	Title	Page
4.1	Topology of PI application	III – 3
4.2	PI front panel	III – 4

Index of Pictures (continues)

5.1	Shield connection of the tap measurement cables	III – 6
5.2	Resistors configuration of the potentiometric transmitter in intermediary positions of the on-load tap changer	III – 8
5.3.a	Manual/Automatic remote programming using a single programming contact	III – 12
5.3.b	Manual/Automatic remote programming using two programming contacts	III – 12
5.4	Contacts connection of Raise/Lower external commands of Automatic and Manual operation devices	III – 13
5.5	PI signaling contacts	III – 13
6.1	PI connection diagram	III – 14
7.1	PI outline dimensions	III – 15

4. Topology for PI application

For each On-Load Tap Changer it is used a unity of the Position Indicator and Controller PI. The serial communication RS485 ports of the PI allow the serial communication of them with an external data acquisition system (supervisor system). See figure 4.1.

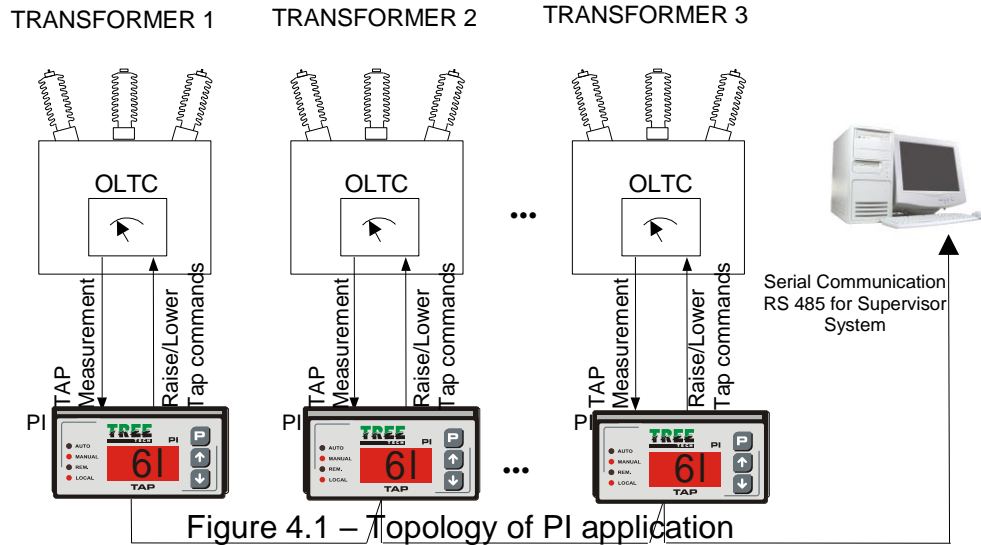

Figure 4.1 – Topology of PI application

In the picture 4.2 it is shown the PI front panel, composed by:

- 1) Indicator LED for the command mode Manual selected (in Automatic mode this LED turns off);
- 2) Indicator LED for the command mode Remote selected (in Local mode this LED turns off);
- 3) P, ↑ and ↓ front keys, with the functions:
 - Manual/Automatic and Local/Remote selections;
 - Raise/Lower tap position manual commands;
 - PI configuration.
- 4) Three-digit display for indicating:
 - Current tap position;
 - Position change in progress;
 - Support to the Manual/Automatic and Local/Remote selections;
 - Support to the PI configuration;
 - Indication codes for error conditions.

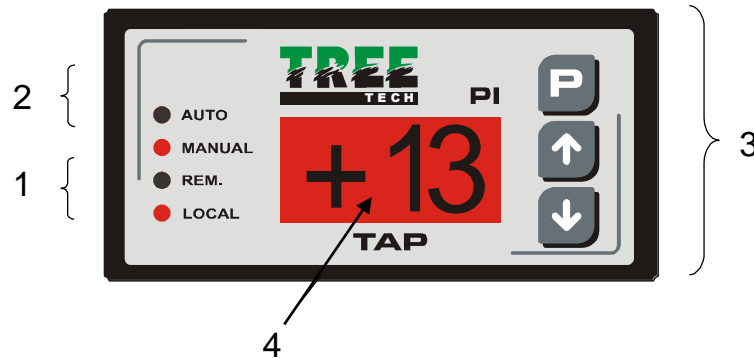

Figure 4.2 – PI Front panel

5. Inputs and Outputs

The following described Inputs and Outputs are available in the PI. A general vision of all the inputs and outputs can be observed in chapter 6.

5.1 Auxiliary power and Ground

The PI is capable to operate with auxiliary power in the range from 85 to 265V, in AC or DC, 50 or 60Hz, with consumption lower than 6W. It must be effected the connection of the terminal corresponding to the ground.

- ◆ Power input: terminals 16 and 17;
- ◆ Ground: terminal 15.

5.2 Tap changer position measurement

The PI performs the on-load tap changer position measurement in order to make this information available to the user. This measurement is accomplished by a PI input, specific for connecting a potentiometric position transmitter of the on-load tap changer.

The PI is provided by an internal microcontroller exclusively dedicated to the necessary calculation for the tap position measurement, verification of its consistency and compensation of the measurement cables resistance.

- ◆ Tap measurement input: terminals 12, 13 and 14 (cursor, start and end, respectively).

5.2.1 Connection cables for tap measurement

The connection of the pontentiometric position transmitter of the on-load tap changer to the PI is accomplished by three wires: the cursor, the start and the end of the potentiometric transmitter. The three wires must have the same length and size.

For this connection, it must be used shielded cable in the whole course, from the tap changer cabinet to the PI, with the shield grounded in a single point.

If it is not used a single shielded cable for the whole course, due to intermediary terminal blocks connection, the shield continuity must be ensured through the interconnection of the shield extremes. See picture 5.1. The unshielded stretch cable, due to seam, must be as short as possible.

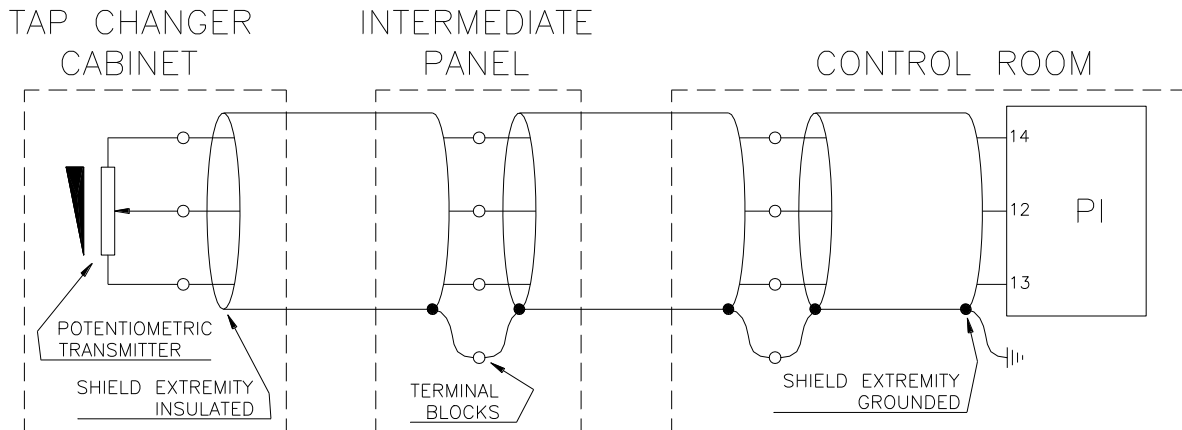

Figure 5.1 – Shield connection of tap measurement cable

The PI performs the automatic compensation of the connection cables resistance from the pontentiometric transmitter to the PI, and to such performance, the three wires must have the same length and size, and the maximum acceptable resistance for each wire is 8Ω . Due to this maximum resistance and the size of the cables used, it can be obtained the maximum permitted length for them.

Considering cables with typical resistance of $13.3 \Omega/\text{km}$, $7.98 \Omega/\text{km}$ and $4.95 \Omega/\text{km}$ for the sizes $1,5\text{mm}^2$, $2,5\text{mm}^2$ and 4mm^2 respectively (non-tinned cables), the maximum lengths are shown in the following table.

Cables Size	Typical Resistance	Maximum Length
0.5 mm ²	39.0 Ω/km	200 m
0.75 mm ²	26.0 Ω/km	300 m
1 mm ²	19.5 Ω/km	400 m
1.5 mm ²	13.3 Ω/km	600 m
2.5 mm ²	7.98 Ω/km	1000 m
4 mm ²	4.95 Ω/km	1600 m

5.2.2 Requirements for the tap position transmitter

The on-load tap changer position transmitter must be of the potentiometric type, with its resistance changing from zero to the maximum value for the start and finish tap changer positions respectively.

In case of tap changers with "intermediary" positions, namely, transition positions that have the same voltage of other adjacent positions, as shown in the following table, the resistors of the potentiometric crown relative to these positions must be removed and/or short circuited, as shown in the example of the picture 5.2. All the intermediary positions (in the example, 6A, 6 and 6B) will be indicated as tap "6", because they have the same voltage.

Tap Position	Voltage (V)	Current(A)	Resistance Cursor/Initial Position (example for 10Ω/step)
1	12420	3220,6	0
2	12696	3150,6	10
3	12972	3083,6	20
4	13248	3019,3	30
5	13524	2957,7	40
6A	13800	2898,6	50
6			50
6B			50
7	14076	2841,7	60
8	14352	2787,1	70
9	14628	2734,5	80
10	14904	2683,8	90
11	15180	2635,0	100

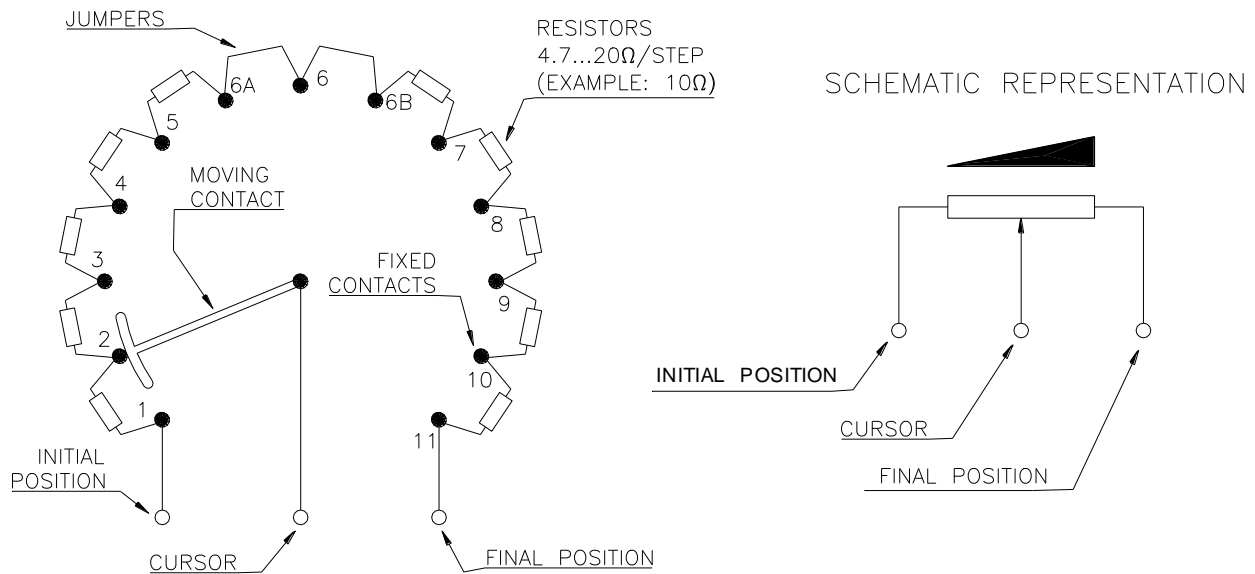

Figure 5.2 – Configuration of potentiometric transmitter resistors at tap changer intermediate positions

The SPS accepts resistance by potentiometric transmitter step (the value of each individual transmitter shown in the picture 5.2) in the range from 4,7 to 20Ω, and the total resistance of the transmitter from 9,4 to 1000Ω. The mobile contact (cursor) of the potentiometric transmitter can be "close before open" or "open before close" type, indifferently.

5.3 Analog output of tap changer position

The PI has an analog output in current loop for remote indication of the tap changer position. The current output value range can be selected using the programming performed in the front of the PI as shown in one of the following options. The output maximum voltage is 12V, what accepts that be connected the maximum loads indicated by the side of each option:

Output Option	Maximum Load	Output Option	Maximum Load
0...1mA	12000Ω	-1...+1mA	12000Ω
0...5mA	2400 Ω	-5...+5mA	2400 Ω
0...10mA	1200 Ω	-10...+10mA	1200 Ω
0...20mA	600 Ω	-20...+20mA	600 Ω
4...20mA	600 Ω	-	-

The current output will change linearly inside the selected range, proportionally to the current tap position. This way, the output value for a given tap position can be calculated by the simple formula as follows:

$$\text{mA output} = \frac{(\text{mA end scale}) - (\text{mA begin of scale})}{(\text{Final Tap}) - (\text{Initial Tap})} \times (\text{Present Tap} - \text{Initial Tap}) + (\text{mA begin of scale})$$

If a Tap Reading Error (E08) occurs, the current output will keep indicating the last read tap position before the Error has occurred.

- ◆ Analog output: terminals 10(-) and 11(+).

5.4 Raise/Lower Tap output contacts

The output contacts for the Raise Tap and Lower Tap commands of the PI are directly connected to the command circuit of the corresponding on-load tap changer, and generally will act energizing the Raise/Lower contactors, which energize the driving motor.

All the tap changing commands, originated locally by the front of the PI, remotely by dry contacts or by serial communication, are retransmitted to the on-load tap changer by the Raise/Lower Tap output contacts.

These contacts have momentary acting, in such manner that for each tap changing command emitted by the PI, they will close a single time for about 0,5 second. For this reason, on-load tap changers with intermediary positions, namely, transition positions that have the same voltage of others adjacent positions, as exemplified in the sub-chapter 5.2.2, must have automatic skipping of the intermediary positions. Still considering the example of the sub-chapter 5.2.2, if the tap changer is at the position 5, and the PI emits a single Raise Tap command, the on-load tap changer must move from the position 5 to 6a, and right after from 6a to 6, automatically.

The Raise/Lower Tap output contacts can switch loads up to 250Vdc or 250Vac, with maximum power of 70W or 220VA respectively. Their conduction capacity (thermal current) is 2A continuously:

- ◆ Raise/Lower Tap output contacts: terminals 18 (common point), 19 (Raise Tap) and 20 (Lower Tap).

5.5 Contact inputs for Remote Programming/Command

The inputs for dry contacts of each PI allow that the programming and the commands to the OLTC be remotely performed. The contacts connected to these inputs must be free of any external potential, and they are energized by an internal potential of the PI, by a common point for all the contacts.

To ensure that a transmitted command be recognized by the PI, the contacts must keep closed for a minimum time of 0.2 second.

- ◆ Local/Remote programming input: terminals 1, 2 and 3 connected together;
- ◆ Manual/Automatic programming input: terminal 4;
- ◆ Raise/Lower Tap command inputs: terminals 5 (Raise) and 6 (Lower);
- ◆ Common point for all the inputs: terminal 9.

5.5.1 Local/Remote Programming

This input allows the remote selection of the Local/Remote command mode.

A pulsed command must be used; this command mode is reversed (from Local to Remote or vice versa) every time the contact connected to the programming input is momentarily closed. If the contact closes and keep closed, there will be an only inversion in the Local/Remote command mode. Additional inversions will be possible only if the contact opens and returns to close.

5.5.2 Manual/Automatic programming input

This input allows the remote selection of the Manual/Automatic command mode. It must be used command by pulse; the command mode is reversed (from Manual to Automatic or vice versa) every time the contact connected to the Manual/Automatic programming input is momentary closed. If this contact close and keep closed, there will be an only inversion in the Manual/Automatic command mode. Additional inversions will be possible only if the contact opens and returns to close.

It is also possible to perform the Manual/Automatic selection using two independent contacts instead of a single contact, being one of them with the Manual function and the other one with the Automatic function. For this proceeding, it must be used the Manual/Automatic reversible auxiliary contact. Comparing to the picture 5.3.a, where it is shown the alternative of a single command contact, and the picture 5.3.b, with the alternative of independent contacts, it can be observed that in both cases, the programming input receives pulses for state inversion, but in the second case the pulse only reaches this input if the contact corresponding to the opposite condition to the current SPS programming is closed. If the contact corresponding to the current SPS condition is closed, this input does not receive the inversion pulse and it is kept in the current condition.

Observe that the Automatic/Manual auxiliary contact of the SPS shown in the picture 5.3.b is used simultaneously in the circuit of the Raise/Lower Tap external command contacts, as described in the sub-chapter 5.5.3.

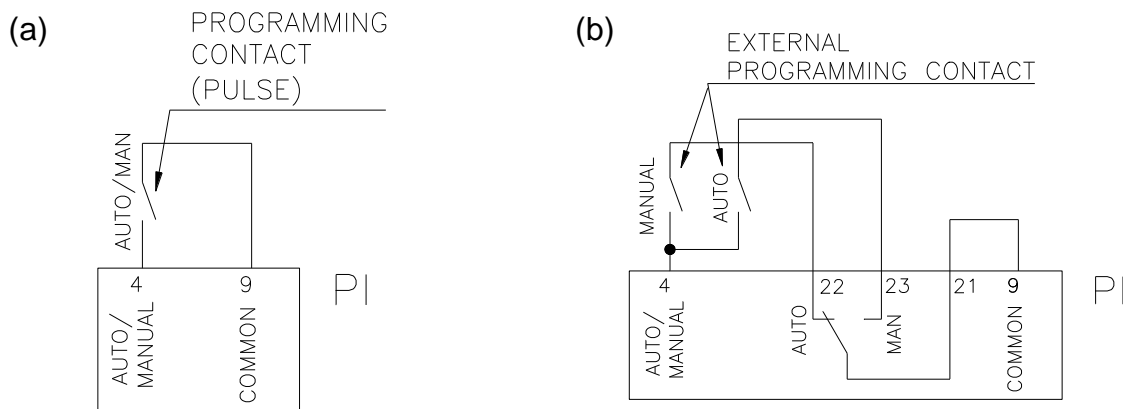

Figure 5.3 – Remote programming Manual/Automatic. (a) Using a single programming contact. (b) Using two programming contacts.

5.5.3 Raise/Lower Tap Command inputs

By these inputs, it is possible that Raise/Lower Tap commands be generated by external devices to the PI. These devices are divided into two categories, Automatic command and Manual command. As an example, we can mention two of the most commonly used, which are the Voltage Regulator Relay for automatic command and the RTU (Remote Terminal Unity) for remote manual command.

Among the four possible combinations for the PI's Manual/Automatic and Local/Remote command modes, in only one of them the commands received in the Raise/Lower Tap contacts inputs are not obeyed, that it is the Manual and Local combination. For this reason, to avoid that the Automatic and Remote Manual commands be received and followed simultaneously by the PI, it is used the Manual/Automatic auxiliary contact of the PI for the interlocking, as shown in the picture 5.4.

Observe that the Automatic/Manual auxiliary contact of the PI shown in the picture 5.4 can be used simultaneously in the circuit of Manual/Automatic remote selection, as described in the sub-chapter 5.5.2.

It must be carefully observed the correspondence between the raise/lower tap and raise/lower voltage commands. In some applications, raise tap can mean lower voltage and vice versa. The Raise/Lower inputs of the PI always refer to the tap position.

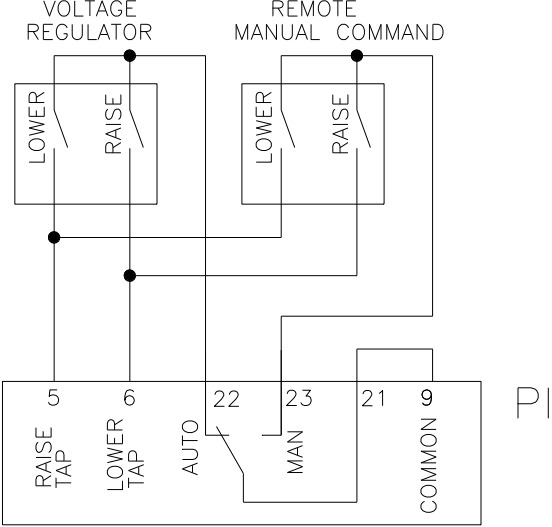

Figure 5.4 – Connection of external command contacts Raise/Lower for Automatic and Manual operation devices.

5.6 Output Relays for Signaling

The PI is supplied by output contacts for signaling of the operative conditions and/or of alarm that can be present.

The signaling contact distribution is shown in the picture 5.5.

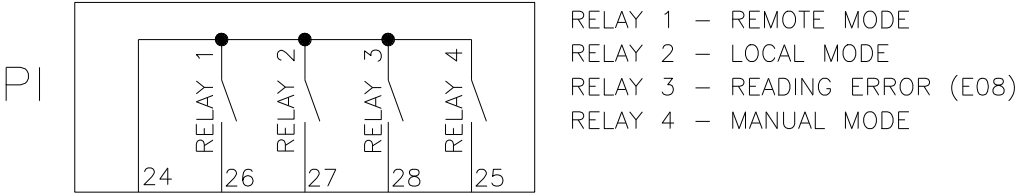

Figure 5.5 – PI signaling contacts.

5.7 Serial Communication RS485

Each PI has a serial communication port RS485. By this communication channel can be accessed all the information, selections and commands of PI.

It must be used a 120Ω termination resistor in each extreme of the communication network. The cable used must be the shielded twisted-pair type, grounded in a single point.

If it is not used a single shielded twisted-pair cable for the whole course, due to intermediary terminal blocks connection, it must be ensured the shield continuity, by connecting the shield extremes of the several cables. The cable stretch without shield, due to seam, must be as short as possible. Maximum length of the RS485 serial communication cables must be 1300 meters.

6. Connection diagrams

In the picture 6.1 are shown the PI inputs and outputs connections.

Chapter 5 shows a more detailed view of the function and of the operation manner of each input/output, here described.

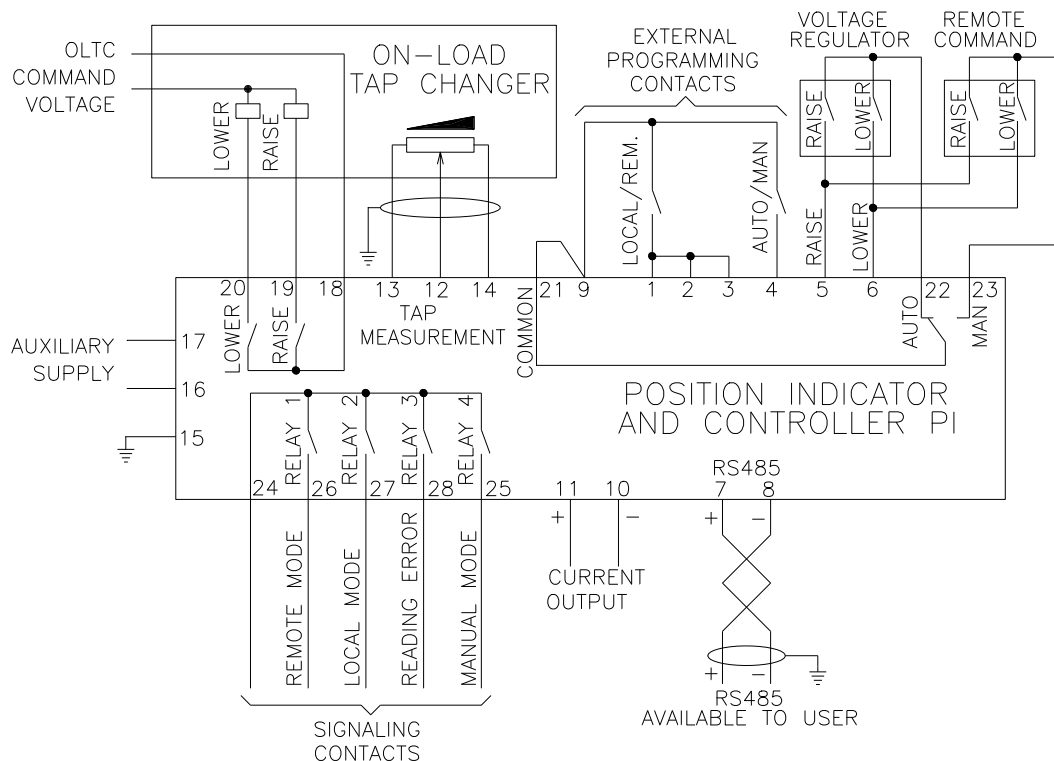

a) Potentiometric input (default)



Figura 6.1 – PI Connection Diagram

7. Mechanical Installation

The PI must be installed protected from weather, inside the control panels or sheltered in building. In any of these cases, there must be an anti-condensation system.

The PI is appropriate for installation of the built-in type; it can be fixed, for an example, in control cubicle door or front plate. The fixing straps are provided with the PI. In the picture 7.1 are shown the equipment outline dimensions, and the dimensions of the sheet cutout for its insertion. Special attention must be given to the thickness of the painting layers in the sheet where the is going to be inserted, because in some cases, when a large thickness painting is used, the lowering of the indenting area can even block the equipment insertion.

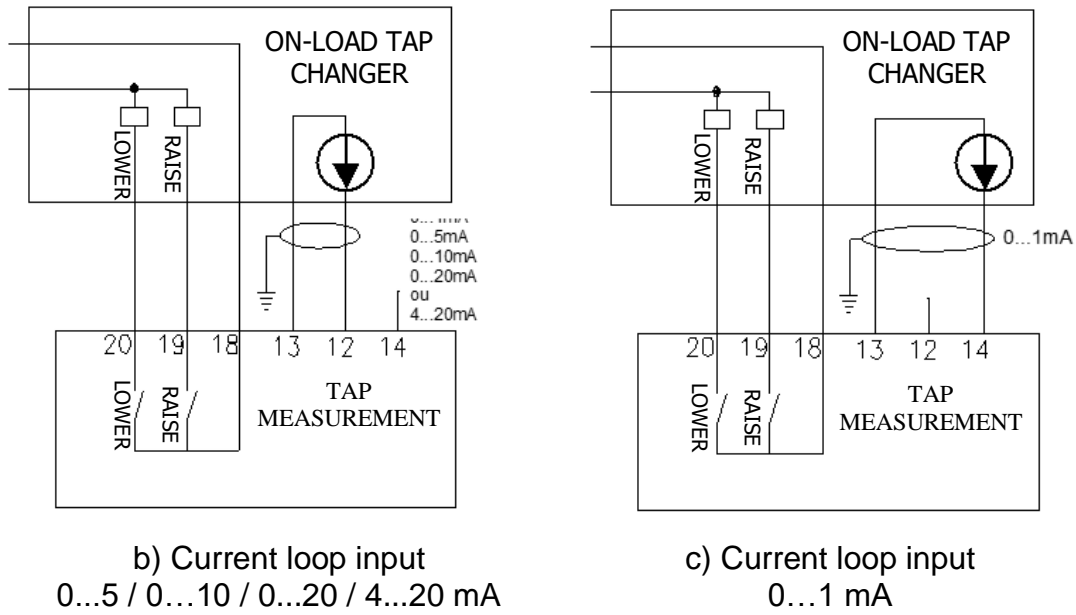
The connection terminals are installed in 2 removable connectors in the rear part of the PI, favoring the connections. It can be used cables from 0.5 to 2.5mm², nude or with terminals of pin (or needle) type.

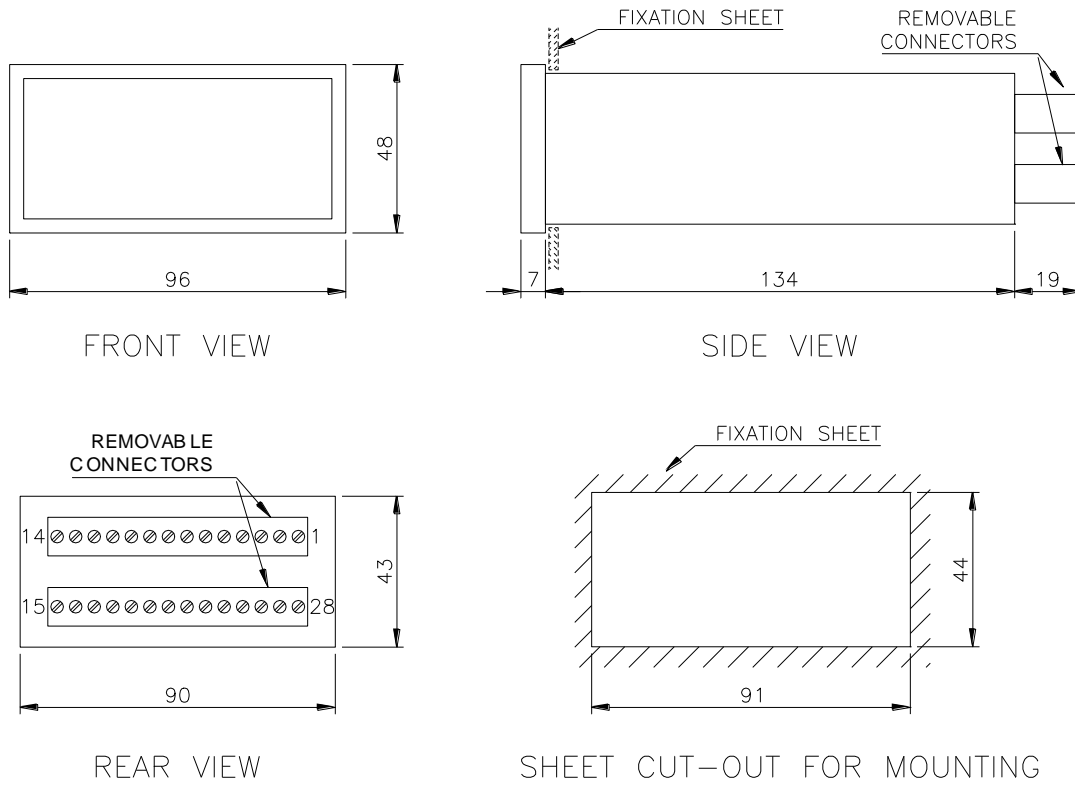

ALL DIMENSIONS IN mm

Figura 7.1 – PI Outline Dimensions

Section IV – Start-up

Index of Subjects

Chapter	Title	Page
8	Proceeding to start the operation	IV – 2
9	Parametering	IV – 3
9.1	Parameter ADR	IV – 4
9.2	Parameter TAP	IV – 4
9.3	Parameter IDC	IV – 5
9.4	Parameter CNT	IV – 6
9.5	Parameter RES	IV – 6
9.6	Parameter CMT	IV – 7
9.7	Parameter OCS	IV – 8

Index of Pictures

Picture	Title	Page
9.1	Individual resistors (step resistance) of the on-load tap changer potentiometric transmitter	IV – 7

8. Proceeding to start the operation

As soon as the equipment installation according to the Section III of this manual is done, the starting the operation must follows the following basic steps.







- Disable the OLTCs commands (example: turn off the motors switches or select the OLTC for Local command) before energizing the PI. During this period, the commands that maybe necessary for the tap change must be performed in the proper tap changer cabinet;
- Check the correction of the electric connections (e.g.: by continuity tests);
- Energize the PI with the power voltage of 85 ~ 265Vdc/Vac;
- Perform the whole PI parameterization, according to the instructions in the sup-chapter 9;
- Put the PI in Local and Manual command modes (see sub-chapter 3.2);
- If there is no error indications (see sub-chapter 3.6), enable the tap changers remote command, allowing the command by the PI;
- Command manually the OLTC by the corresponding PI, passing by all the tap positions. Observe if there is no inversion between the raise and lower tap commands, and also observe if the tap indication is correct in all the positions and if there is no occurrence of tap reading errors (E08);
- Simulate the several operative conditions (local, remote, manual and automatic), verifying the operation of the signaling contacts;
- Select the final configuration desired for operation, that is, command modes Manual or Automatic and Local or Remote.





9. Parametering

To ensure the correct operation of the PI, several parameters must be settled in it, which will provide the equipment the necessary information for its operation. Its front keyboard can perform the adjustments, with the display assistance, or by the serial communication port available to the user.

The proceeding to access the several adjustment parameters of the PI is presented below. Observe that, to access the parameterization, it is primarily necessary to enter in the programming menu.

Forward, in the sub-chapters 9.1 to 9.7, is the description of each parameter, and all the advises for their selection.

Procedure	Effect	Preview
Press Key P for a moment.	It is accessed the first programming menu, with the Local/Remote selection. The current condition of this selection is shown in the display by the initials LOC or REM respectively.	 <p>OR</p> 
Press key P again, keeping it pressed for around 3 seconds	It is accessed the first parameter for adjustment, indicated in the display by the initial ADR (PI address in the serial communication).	
Press ↑ or ↓ keys for a moment	It is indicated in the display the current value of the parameter ADR	
Press ↑ or ↓ keys for a moment	The value of the parameter ADR is changed	 <p>...</p> 

Procedure	Effect	Preview
Press Key P for a moment.	Repeating these 3 steps, the all the further PI parameters can be accessed and edited : <ul style="list-style-type: none"> - TAP (total number of taps of the tap changer) - IDC (tap indication type) - CNT (central tap of the tap changer) - RES (resistance by step of the potentiometric transmitter) - CMT (time for tap change) - OCS (output current mA) 	
Press ↑ or ↓ keys for a moment		
Press ↑ or ↓ keys for a moment		
		
Press Key P for a moment.	The PI leaves the parameterization menu, returning to the indications described in 3.1 (in general, the current tap position)	

9.1 Parameter ADR

It is the PI address in the serial communication with a supervisory system. As general rule, each device connected to the same communication network must have a single address, without repetition.

Adjustment range: 0 to 31.

9.2 Parameter TAP

It is the total number of on-load tap changer positions. In cases of tap changers with “intermediary” positions, in other words, transition positions that have the same voltage than other adjacent positions, as exemplified in the following table, the parameter TAP value must not include the intermediary positions, because these positions (in the examples: 6A, 6 and 6B) will be indicated as tap “6”, as they have the same voltage. In this example, the parameter TAP is programmed as 11.

Tap position	Voltage (V)	Current (A)
1	12420	3220.6
2	12696	3150.6
3	12972	3083.6
4	13248	3019.3
5	13524	2957.7
6A	13800	2898.6
6		
6B		
7	14076	2841.7
8	14352	2787.1
9	14628	2734.5
10	14904	2683.8
11	15180	2635.0

Adjustment range: 2 to 50.

9.3 Parameter IDC

It is the tap indication type adopted for presentation in the PI display, that generally follows the same indication type used in the proper on-load tap changer. There are four indication options, shown in the following table.

Parameter IDC	Description	Example 1	Example 2
0	Bilateral numerical	-8 ... 0 ... +8	-12 ... 0 ... +20
1	Inverted bilateral numerical	+8 ... 0 ... -8	+12 ... 0 ... -20
2	Alphanumerical	8L ... N ... 8R	12L ... N ... 20R
3	Inverted alphanumerical	8R ... N ... 8L	12R ... N ... 20L
4	Simple numerical	1 ... 17	1 ... 33

In the example 1, it is presented a tap changer with a total tap number equal 17 (TAP=17), with the neuter position (0 and N) centralized in the Bilateral numerical and Alphanumerical indications. The example 2 presents a tap changer with a total

of 33 taps, with the neuter position decentralized in the Bilateral numerical and Alphanumerical indications.

9.4 Parameter CNT

It is the position, counted from the beginning of the measurement range, where the on-load “neuter” tap changer is found. This parameter will have practical effects only when the Bilateral numerical and Alphanumerical indication types are selected (see sub-chapter 9.3), because it allows that the tap changer positions with raise and lower ranges of asymmetric voltage be indicated.

The following table exemplifies the effect caused by this parameter in the tap indication for a 33-position tap changer and Bilateral numerical and Inverted alphanumerical indication types.

Parameter CNT	Bilateral numerical Example	Inverted alphanumerical Example
15	-14 ... 0 ... +18	14R ... N ... 18L
16	-15 ... 0 ... +17	15R ... N ... 17L
17	-16 ... 0 ... +16	16R ... N ... 16L
18	-17 ... 0 ... +15	17R ... N ... 15L
19	-18 ... 0 ... +14	18R ... N ... 14L

Adjustment range: 2 to 50.

9.5 Parameter RES

It is the resistance by step of the on-load tap changer potentiometric transmitter (in other words, each individual resistor value, shown in the picture 9.1).

Adjustment range: 4.7 to 20Ω.

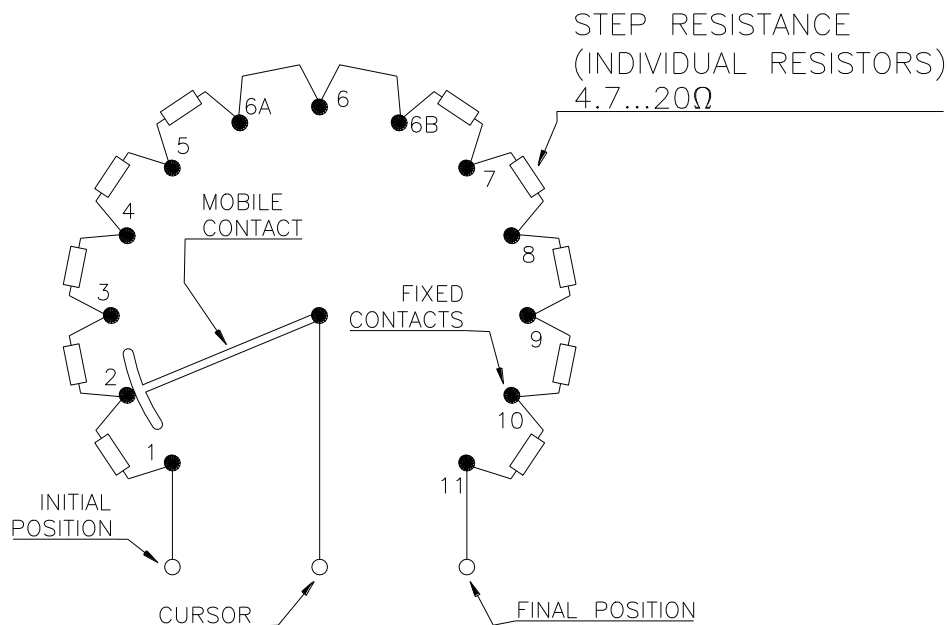

Figure 9.1 –Individual resistors (step resistance) of OLTC potentiometric position transmitter

9.6 Parameter CMT

The parameter CMT (time for a tap change) is associated to the period of time that the on-load tap changer takes to perform a complete tap change. The time adjusted for this parameter is used by the PI for the following:

- Timing for tap measuring error E08, to avoid undesirable alarm during a tap change due to potentiometric transmitter momentary opening or short-circuiting of adjacent positions.
- During the CMT time counting, after the emission of a tap change command, the PI indicates in its display that the tap change is in progress by presenting the symbols $\wedge\wedge\wedge$ or $\vee\vee\vee$ (raising or lowering tap changer, respectively).

Due to these functions performed by the PI, based on the parameter CMT, its adjustment must be superior, with a 2-second minimum margin, than the longest time that the tap changer takes to tap change. In the case of transformers with intermediary tap, the longest change time is located in the tap change that demands to pass by intermediary positions. Consider the following example, which the time to perform only one tap change is 5 second:

Tap changer position	1	2	3	4	5	6A	6	6B	7	8	9	10	11
Tap change time (s)													

As it can be observed, the change from position 5 to 6 and from 6 to 7 demands to pass by the intermediary positions 6A and 6B, respectively. Thus, the longest change time is, as a matter of fact, 10 seconds, and not 5, as initially thought. This way, the parameter CMT adjustment must be the longest tap change time (10s) plus the minimum delay (2s), totaling the ideal 12-second adjustment.

It is allowed adjustments longest than the one described above, however they present an inconvenience that can unnecessarily turn the successive tap changes very slow.

Adjustment: 1 to 100 seconds.

9.7 Parameter OCS

It is the selection of the value range of current in loop analog output of the PI, for remote indication of the on-load tap changer position. The sub-chapter 5.3 presents details of the operation mode of the current output.

The options shown in the following table are available:

Parameter OCS	output Range	Parameter OCS	output Range
1	0...1mA	2	-1...+1mA
3	0...5mA	4	-5...+5mA
5	0...10mA	6	-10...+10mA
7	0...20mA	8	-20...+20mA
9	4...20mA	-	-

Section V – Troubleshooting

Index of subjects

Chapter	Title	Page
10	Troubleshooting	V – 2
10.1	Manual/Automatic Selection	V – 2
10.2	Raise/Lower tap commands	V – 2
10.3	Local and remote indication of tap position	V – 3
10.7	Error indication E08	V – 4

10. Troubleshooting

If difficulties or troubles appear in the operation the PI, we suggest you to consult the possible causes and simple solutions presented below. If this information is not sufficient to solve the difficulties, please get in contact with Treotech's technical assistance or its authorized agent.

10.1 Manual/Automatic Selection

- The PI does not allow the Manual/Automatic selection to be performed in its front panel

Probable Causes	Possible Solutions
The PI is in Remote operation mode, therefore, it only follows the selections performed via dry contacts or via serial communication	Select the PI for Local mode (see sub-chapter 3.2)

- The PI does not allow the Manual/Automatic selection to be performed via dry contacts or via serial communication

Probable Causes	Possible Solutions
The PI is in Local operation mode, therefore, it only follows the selections performed in its front panel	Select the PI for Remote mode (see sub-chapter 3.2)

10.2 Raise/Lower tap commands

- The PI does not follow the Raise and Lower tap commands performed in its front panel

Probable Causes	Possible Solutions
The PI is in Remote operation mode, therefore, it only follows the selections performed via dry contacts or via serial communication	Select the PI for Local mode (see sub-chapter 3.2)
The PI is in the Automatic mode, therefore, it only follows the commands generated by the voltage regulator relay (or similar device)	Select the PI for Manual mode (see sub-chapter 3.2)
The on-load tap changer is in Local mode or it is turned off, or there is no power/command supply, or any charging switch is turned off	Verify the on-load tap changer, the power/command circuit charging switches and the auxiliary power.

- The PI does not follow the Raise and Lower tap commands performed via dry contacts or via serial communication

Probable Causes	Possible Solutions
The PI is in Local operation mode, therefore, it only follows the selections performed in its front panel	Select the PI for Remote mode (see sub-chapter 3.2)
The PI is in the Automatic mode, therefore, it only follows the commands generated by the voltage regulator relay (or similar device)	Select the PI for Manual mode (see sub-chapter 3.2)
The on-load tap changer is in the Local mode or it is turned off, or there is no power/command supply, or any charging switch is turned off	Verify the on-load tap changer, the power/command circuit charging switches and the auxiliary power.

10.3 Local and Remote Tap position indications

- The indication of the tap position in the front panel of the PI does not correspond to the real position of the tap changer

Probable Causes	Possible Solutions
It was not selected the correct option of PI tap indication type	Select the indication type corresponding to your tap changer according to the instructions described in the sub-chapter 9.3
It was not selected the correct "neuter" tap position option of the tap changer, related to indication of bilateral numerical (-/+) or alphanumerical (L/R) type.	Select the "neuter" tap position of the tap changer according to the instructions described in the sub-chapter 9.4

- The on-load tap changer has bilateral numerical (-/+) or alphanumerical (L/R) tap indication, and the tap position indication in the front of the PI is inverted in relation to the real position

Probable Causes	Possible Solutions
It was not selected the correct option of tap indication type of the PI	Select the indication type corresponding to your tap changer according to the instructions described in the sub-chapter 9.3

- The PI's current output mA for remote indication of tap position does not correspond to the expected value

Probable Causes	Possible Solutions
It was not selected the correct option of the PI's output current range	Select the wanted output current range according to the instructions described in the sub-chapter 9.7
The calculation of the expected value for the current output is mistaken	See the calculation formula of the expected value for the current output in the sub-chapter 5.3

10.4 Error Indication E08 – Tap position reading error

To easy the tap reading error diagnostic, it is convenient to consult in the PI the cause of the reading error and the tap position that it was at the moment of the error occurrence. Follow the following proceeding:

- Press momentarily the key P;
- Press simultaneously the keys P and ↑. It will be shown in the display the cause code of the last reading error occurred, C1, C2 or C3;
- Press momentarily the key P. It will be shown in the display the tap position that was the tap changer at the moment the error occurred.

Having the cause code of the reading error, verify the probable causes and possible solutions in the table below.

Code	Probable Causes	Possible Solutions
C1	Internal defect in the PI (communication failure between microcontrollers)	Replace the defected PI by a reserve unity
C2	Connection cables of the potentiometric transmitter are not shielded type	Replace the connection cables from the potentiometric transmitter to the PI by shielded cables, according to instructions described in the sub-chapter 5.2.1
	Shield of the connection cables from the potentiometric transmitter to the PI are grounded in more than one point or are not grounded, or without of shield continuity along the course.	Ground the connection cables shield from the transmitter to the PI in a single point, and keep the shield continuity, according to the instructions described in sub-chapter 5.2.1
	Poor contact in the potentiometric position transmitter cursor or in the connection cables from it to the PI	Fix the poor contact in the cables or in the potentiometric transmitter cursor
C3	Connection cables from the potentiometric transmitter to the PI with resistance higher than 8 ohms by wire – very reduced size in function of the traveled distance	Replace the connection cables from the potentiometric transmitter to the PI by cables with an adequate size, according to the instructions described in the sub-chapter 5.2.1
	Connection cables from the potentiometric transmitter to the PI with different sizes or lengths in each wire	Replace the connection cables from the potentiometric transmitter to the PI by shielded cables with identical sizes in the 3 wires, according to instructions described in the sub-chapter 5.2.1
	Poor contact in the potentiometric position transmitter cursor or in the connection cables from it to the PI	Fix the poor contact in the cables or in the potentiometric transmitter cursor
	Error in the adjustment of the TAP and/or RES parameters of the PI	Correct the adjustment of the TAP and/or RES parameters according to the instructions described in the sub-chapters 9.2 and 9.5
	The potentiometric transmitter has step resistors installed in the intermediary positions of the tap changer	Remove the resistors from the intermediary positions of the tap changer, replacing them by jumpers, according to the instructions described in the sub-chapter 5.2.2
	The step resistors of the potentiometric transmitter have tolerance higher than 1% of its nominal value	Replace the step resistors of the potentiometric transmitter by other of better precision or equal to 1%

Section VI – Appendix

Index

Appendix	Title	Page
A	Technical Data	VI – 2
B	Type tests	VI – 3
C	Order Specification	VI – 4
D	Optional Accessories	VI – 5
D.1	Transmitter of Potentiometric Position of Magnetic type	VI – 5
E	Registers Map	VI – 6
E.1	General Information	VI – 6
E.2	Read and Write Registers	VI – 6
E.3	Read Only Registers	VI – 7

Appendix A – Technical Data

Power Voltage:	85 to 265 Vdc/Vac 50/60Hz
Consumption:	< 5 W
Operation Temperature:	-10 a +70 °C
Protection Degree:	IP 40
Fixation:	Built-in panel
Tap Measurement input:	Potentiometric, 3 wires
Number of Taps of the OLTC:	2 to 50
Total resistance of the potentiometric transmitter:	9.4 to 1000Ω
Resistance by step of the potentiometric transmitter:	4.7 to 20Ω
Analog Output Options and Maximum Load:	0 ... 1 mA - 12000Ω 0 ... 5 mA - 2400Ω 0 ... 10 mA - 1200Ω 0 ... 20 mA - 600Ω 4 ... 20mA - 600Ω
Maximum error of the Analog Output:	0.5% of the scale ending
output Contacts:	Potential free
Maximum Switching Power:	70 W / 250 VA
Maximum Switching Voltage:	250 Vdc/Vac
Maximum Current of Conduction:	2.0 A
Serial communication portal:	1 (one) RS485 for connection to supervisory system
Communication Protocol:	Modbus RTU (slave)

Appendix B –Type Tests

Surges and transients (IEC 60255-6)

Peak value 1 ^o cycle:	2,5 kV
Frequency:	1,1 MHz
Time:	2 s
Repetition Rate:	400 (surges/s)
Declining a 50%:	5 cycles

Impulse (IEC 60255-5)

Wave form:	1,2/50 µs
Amplitude:	5 kV
Number of pulses:	3 negative e 3 positive with break of 5 seconds among pulses.
Energy:	0,5J

Applied Voltage (IEC 60255-5)

Tolerable voltage nominal to the industrial frequency:	2,0 kVrms, 60 Hz, for 1 minute between circuits and mounting panel.
--	---

Electromagnetic Susceptibility (IEC 61000-4-3)

Severity Level:	3
Frequency:	20 to 2000MHz
Field intensity:	10 V/m

Electrostatic Discharges (IEC 61000-4-2)

Air mode:	10 discharges level 3 (8kV)
Contact mode:	10 discharges level 3 (8kV)

Prompt Electric Transients (IEC 61000-4-4)

Severity Level:	4
Test in the Power input:	4kV
Test in the inputs/outputs:	2kV

Climatic Assay(IEC 60068-2-14)

Temperature Range:	-10 a +70°C
Test timing:	6 hours

Appendix C – Specification for Order

The PI was schemed to allow a universal application, exempting specific data information during the equipment purchase. The following selections contribute for its universal application. These selections are performed in the firmware (internal software) of the PI by its front panel (see sub-chapter 8.1):

- Number of tap changer positions: from 2 to 50;
- Tap indication type: simple numerical, bilateral numerical or alphanumeric, with direct or inverted indication and with “neuter” tap that can be selected;
- Resistance by step of the potentiometric transmitter: from 4,7 to 20 ohms;
- Maximum tap change time of the tap changer: from 1 to 100 seconds;
- Current output for tap remote 0-1, 0-5, 0-10, 0-20 or 4-20mA, with bipolar output option (-/+);

Thus, during the PI purchase it is not necessary to inform none of the data above described, because the user parameterizes the device according to its use. Informing that you want to get the PI is enough.

Appendix D – Optional Accessories

D.1 Potentiometric Position Transmitter of Magnetic type

The majority of the recent on-load tap changers, and some of the antique ones, is supplied in the factory by potentiometric position transmitter or dry contacts that allow the creation of the transmitter by means of the adequate step resistors installation.

However, in case of tap changers that do not have any of these alternatives, Treetech can provide potentiometric position transmitters magnetically operated, without mechanical contacts, what makes its installation easy in antique equipment already in operation.

Contact us regarding to this equipment supply and to get its installation services.

Appendix E – Registers Map

The information described in this appendix permit that all the measurements, selections, commands and adjustments of the PI be performed by the serial communication port RS485. The utilization of this serial communication is optional.

E.1 General Information

Protocol:	Modbus
Mode:	RTU (binary)
Transfer rate:	9600 bps
Data Bits:	8
Stoppage Bits:	2
Parity:	None
Type of memory variable:	40000
Implemented commands:	03 (read, in blocks or individually) 06 (write, only individually)

E.2 Read and Write Registers

Register	Bit (0=LSB, 7=MSB)	Description	Measurement Range or state	Step
0	-	Internal use		
1	-	Taps number (TAP, see sub-chapter 9.2)	2...50	1
2	-	Tap indication type (IDC, see sub-chapter 9.3)	0...4	1
3	-	Neuter tap position (CNT, see sub-chapter 9.4)	2...50	1
4	-	Resistance by step (RES, see sub-chapter 9.5)	47...200 (corresponds to 4,7...20,0 ohm)	1
5	-	Time for tap-change (CMT, see sub-chapter 9.6)	1...100	1
6	-	Internal use		
7	-	Internal use		
8	-	Internal use		
9	-	Internal use		
10	-	Internal use		
11	-	output option mA (OCS, see sub-chapter 9.7)	0...9	1
12	-	Internal use		
13		Internal use		
14		Internal use		
15		Internal use		
16		Internal use		
17		Internal use		
18		Internal use		
19 20	0	Raise command	0=idle 1=raise pulse	-
	1	Lower command	0=idle 1=lower pulse	-
	2	Internal use		
	3	Internal use		
	4	Internal use		
	5	Select Automatic mode	0=idle 1=go to Auto/Bank	-
	6	Select Manual mode	0=idle 1=go to Manual/Ind. Phase	-
	7	Invert Local/Remote selection	0=idle 1=invert	-

E.3 Read Only Registers

33	-	Current tap position	1...50	1
34	0	Internal use		
	1	Internal use		
	2	Command mode Local / Remote	0=Local 1=Remote	-
	3	Command mode Manual / Automatic	0=Manual 1=Automatic	-
	4	Internal use		
	5	Internal use		
	6	Internal use		
	7	Internal use		
35	0	Internal use		
	1	Internal use		
	2	Internal use		
	3	Tap measuring error E08	0=inactive 1= error E08	-
	4	Internal use		
	5	Internal use		
	6	Internal use		
	7	Internal use		