



English

www.treetech.com.br

TECHNICAL MANUAL

TEMPERATURE MONITOR

TM1/TM2



Treetech

Table of contents

1 FOREWORD.....	6
1.1 LEGAL INFORMATION.....	6
1.2 PRESENTATION.....	6
1.3 TYPOGRAPHICAL CONVENTIONS.....	6
1.4 GENERAL AND SAFETY INFORMATION.....	6
<i>Safety Symbols</i>	7
<i>General Symbols</i>	7
<i>Minimum profile recommended for the TM1/TM2 operator and maintainer</i>	7
<i>Environmental and voltage conditions required for installation and operation</i>	8
<i>Instructions for test and installation</i>	8
<i>Cleaning and decontamination instructions</i>	9
<i>Inspection and Maintenance instructions</i>	9
1.5 TECHNICAL ASSISTANCE.....	10
1.6 WARRANTY TERM.....	11
1.7 REVISION CONTROL.....	12
2 INTRODUCTION.....	13
2.1 MAIN FEATURES.....	13
2.2 OPTIONAL FEATURES.....	15
2.3 OPERATION PHILOSOPHY.....	16
3 OPERATION.....	19
3.1 INITIAL SETTINGS.....	19
3.2 FUNCTION OF KEYS.....	21
3.3 CONSULTATION SCREENS.....	21
<i>TM1 Consultation Screens</i>	21
<i>Consultation Screen TM2</i>	23
3.4 COMMANDS.....	24
4 PROJECT AND INSTALLATION.....	26
4.1 SYSTEM TOPOLOGY.....	26
4.2 INPUTS AND OUTPUTS.....	26
4.3 PROJECT AND INSTALLATION.....	28
<i>RTD Temperature Sensors</i>	29
<i>Serial Communication Ports RS485</i>	30
<i>Analogic Outputs</i>	31
<i>Current Transformers</i>	31
<i>Forced Cooling Control</i>	33
4.4 TYPICAL APPLICATION DIAGRAMS.....	41
4.5 MECHANICAL INSTALLATION.....	46
5 PARAMETERIZATION.....	47
5.1 PROGRAMMING.....	47
5.2 ACCESS TO THE PROGRAMMING MENU.....	48
5.3 ACCESS TO SUBMENUS.....	49
<i>Submenu LNG</i>	50
<i>Submenu CLK</i>	50
<i>Submenu ALM</i>	51
<i>Submenu CNF</i>	53
<i>Submenu TRF</i>	61

<i>Submenu FAN</i>	65
<i>Submenu LTC</i>	69
<i>Submenu LOG</i>	71
5.4 TYPICAL ADJUSTS	73
6 START-UP PROCEDURE FOR PUTTIN EQUIPMENT IN OPERATION	74
7 TROUBLESHOOTING	80
7.1 THE DEVICE DISPLAYS SELF-DIAGNOSIS MESSAGES ON THE DISPLAY	80
7.2 TM1/TM2 READS INCORRECT VALUES FOR TEMPERATURES	87
7.3 TM1/TM2 READS INCORRECTLY VALUES FOR LOAD CURRENTS	88
7.4 TM1/TM2 INDICATES INCORRECT VALUES FOR WINDING TEMPERATURES	88
7.5 TM1 DOES NOT COMMUNICATE WITH THE DATA ACQUISITION SYSTEM	88
7.6 REMOTE READING THROUGH ANALOG OUTPUT INCORRECT	89
7.7 TM1/TM2 DOES NOT CORRECTLY ACTIVATE THE FORCED COOLING	89
8 ATTACHMENTS	90
8.1 ATTACHMENT A	90
8.2 ATTACHMENT B	91
8.3 ATTACHMENT C	92
8.4 ATTACHMENT D	93

List of figures

FIGURE 1 – TEMPERATURE MONITORS TM1 AND TM2	14
FIGURE 2 – TEMPERATURE MEASUREMENTS OF LTC, TRANSFORMER AND TEMPERATURE DIFFERENTIAL	17
FIGURE 3 - INSTANTANEOUS AND FILTERED TEMPERATURE DIFFERENTIALS	18
FIGURE 4 – TEMPERATURE INDICATIONS	19
FIGURE 5 – SIGNALING LEDs ON TEMPERATURE MONITOR TM1	20
FIGURE 6 – SIGNALING LEDs ON TEMPERATURE MONITOR TM2	20
FIGURE 7 – SELF-DIAGNOSTIC INDICATIONS	21
FIGURE 8 – BLOCK DIAGRAM	26
FIGURE 9 – DETAIL SHIELD CONNECTION OF RTD SENSOR	30
FIGURE 10 – SHIELD CONNECTION OF SERIAL COMMUNICATION.....	31
FIGURE 11 – CONNECTION DETAILS OF CURRENT TRANSFORMERS DIRECTLY TEMPERATURE MONITORS	32
FIGURE 12 – CONNECTION DETAILS OF CURRENT TRANSFORMERS TO TEMPERATURE MONITORS PREPARED FOR EXTERNAL CILIP-ON CTS.....	33
FIGURE 13 – COMMAND OF 4 EQUAL FORCED COOLING GROUPS SHIFTING THE OPERATION OF GROUPS	35
FIGURE 14 – COMMAND OF 1 FORCED COOLING GROUP WITH PUMPS AND 3 EQUAL GROUPS WITH FANS SHIFTING THE OPERATION OF FAN GROUPS	36
FIGURE 15 – COMMAN OF 2 EQUAL FORCED COOLING GROUPS WITH PUMPS AND 2 EQUAL GROUPS WITH FANS, WITH INDEPENDENTE SHIFTING FOR THE OPERATION OF THE PUMP GROUPS AND THE FAN GROUPS.....	37
FIGURE 16 – COMMAND OF 4 EQUAL FORCED COOLING GROUPS IN 2 TEMPERATURE STAGES, WITH TIMER FOR MOTORS START AND SHIFTING THE GROUPS	39
FIGURE 17 – COMMAND OF 2 EQUAL FORCED COOLING GROUPS WITH COMMAND REDUNDANCY	40
FIGURE 18 – OPTION 1 – 2 RTDs WITH 3 WIRES.....	41
FIGURE 19 - OPTION 2 – 1 RTD WITH 4 WIRES	42
FIGURE 20 – OPTION 3 – 1 RTD WITH 3 WIRES, RTD A.....	43
FIGURE 21 – OPTION 4 – 1 RTD WITH 3 WIRES, RTD B.....	43
FIGURE 22 – CONNECTION TM1/TM2	44
FIGURE 23 – CONNECTION TM1 / MT2	44
FIGURE 24 – CONNECTION MT1 / TM2	45
FIGURE 25 – CONNECTION TM1 / SYNCHRONISM SIGNAL IRIG-B	45
FIGURE 26 – DIMENSIONS OF TM1 AND TM2	46
FIGURE 27 – SELF-DIAGNOSTIC INDICATIONS	80

List of Tables

TABLE 1 – OPERATING CONDITIONS	8
TABLE 2 – REVISION CONTROL	12
TABLE 3 – TM1/TM2 INPUTS	27
TABLE 4 - TM1/TM2 OUTPUTS	28
TABLE 6 – DIGIT 1 FAILURES	81
TABLE 7 – DIGIT 2 FAILURES	82
TABLE 8 – DIGIT 3 FAILURES	84
TABLE 9 – DIGIT 4 FAILURES	86
TABLE 10 – INCORRECT READING OF VALUES FOR TEMPERATURES	87
TABLE 11 – INCORRECTLY VALUES FOR LOAD CURRENTS	88
TABLE 12 – INCORRECT VALUES FOR WINDING TEMPERATURES	88
TABLE 13 – NO COMMUNICATION BETWEEN TM1 AND DATA ACQUISITION SYSTEM	88
TABLE 14 – REMOTE READING THROUGH ANALOG OUTPUT INCORRECT	89
TABLE 15 - INCORRECT ACTIVATE THE FORCED COOLING	89
TABLE 16 – COMPATIBILITY BETWEEN FIRMWARES.....	93

1 Foreword

1.1 Legal Information

The information contained in this document is subject to changes without prior notice.

This document belongs to Treetech Sistemas Digitais Ltda. and may neither be copied, transferred to third parties nor used without express authorization, in terms of law 9.610/98.

Disclaimer:

Treetech Sistemas Digitais reserves the right to make changes without prior notice in all products, circuits and functionalities described herein with the aim of improving their reliability, function or design. Treetech Sistemas Digitais does not assume any liability resulting from application or use of any product or circuit described herein, and does not transmit any licenses or patents under its rights, not even third party rights.

Treetech Sistemas Digitais Ltda. may own patent or other types of registrations and intellectual property rights described in the content of this document. Possession of this document by any person or entity does not give such person or entity any right over these patents or registrations.

1.2 Presentation

This manual presents all the recommendations and instructions for installation, operation and maintenance of the Temperature Monitor – TM1/TM2.

1.3 Typographical Conventions

Throughout this text, the following typographical conventions were adopted:

Bold: Symbols, terms and words that are in bold have greater contextual importance. Therefore, pay attention to these terms.

Italics: Terms in foreign language, alternative or with their use outside the formal situation are written in italics.

1.4 General and Safety Information

This section presents relevant aspects of safety, installation and maintenance of the TM1/TM2.

Safety Symbols

This manual uses three types of risk classification, as shown below:

Caution



The **Caution** symbol is used to alert the user of a potentially hazardous operating or maintenance procedure that demands greater caution in its conduction. There may be minor or moderate injuries, as well as damages to the equipment.

Warning



The **Warning** symbol is used to alert the user of a potentially hazardous operating or maintenance procedure in which extreme caution must be taken. There may be serious injuries or death. Possible damages to the equipment are irreparable.

Electric Shock Hazard



The **Electric Shock Hazard** symbol is used to alert the user of an operating or maintenance procedure that may result in electric shock if not strictly observed. There may be minor, moderate, serious injuries or death.

General Symbols

This manual uses the following general symbols:

Important



The **Important** symbol is used to highlight relevant information.

Tip:



The **Tip** symbol represents instructions that facilitate use and access of functions in the TM1/TM2.

Minimum profile recommended for the TM1/TM2 operator and maintainer

Installation, maintenance and operation of equipment in electric power substations require special cares and, therefore, all recommendations of this manual, applicable standards, safety procedures, safe work practices and good judgment must be used during all handling stages of the Temperature Monitor (TM1 and TM2).

For use of this manual, an authorized and trained person has knowledge of the inherent risks – both electrical and environmental – involved in handling the TM1 and TM2.



Only authorized and trained personnel – operators and maintainers – should handle this equipment.

- a) The operator or maintainer must be trained and authorized to operate, ground, turn on and turn off the TM1/TM2, following maintenance procedures according to the safety practices established, under the sole responsibility of the TM1/TM2 operator and maintainer;
- b) Be trained in the use of IPEs, CPEs and first-aid;
- c) Trained in the working principles of the TM1 and TM2, as well as its configuration.
- d) Follow regulatory recommendations regarding interventions in any type of equipment included in an Electric Power System.

Environmental and voltage conditions required for installation and operation

The table below lists important information on the environmental and voltage requirements:

Table 1 – Operating Conditions

Condition	Interval/Description
Application	Equipment for sheltered use in substations, industrial environments and similar.
Internal/External Use	Internal Use
Degree of Protection (IEC 60529)	IP 20
Altitude* (IEC EN 61010-1)	Up to 2000 m
Temperature (IEC EN 61010-1)	
Operation	-40 °C to +85 °C
Storage	-50 °C to +95 °C
Relative Humidity (IEC EN 61010-1)	
Operation	5% to 95% – Uncondensed
Storage	3% to 98% – Uncondensed
MAINS Supply Voltage Fluctuation (IEC EN 61010-1)	Up to ±10% of the Rated voltage
Overvoltage (IEC EN 61010-1)	Category II
Level of Pollution (IEC EN 61010-1)	Level 2
Atmospheric Pressure** (IEC EN 61010-1)	80 kPa to 110 kPa

* Altitudes greater than 2000 m already have successful applications.

** Pressures of less than 80 kPa already have successful applications.

Instructions for test and installation

This manual must be available to those responsible for installation, maintenance and users of the Temperature Monitor – TM1/TM2.

To guarantee user safety, equipment protection and correct operation, the following minimum cares must be followed during the TM1/TM2 installation and maintenance:

1. Read this manual carefully before installation, operation and maintenance of the TM1/TM2. Errors in installation, maintenance or adjustments of the TM1/TM2

can cause undue operations of the tap changer in load, unsatisfactory voltage regulation, undue alarms or pertinent alarms may also fail to be emitted.

2. The installation, adjustments and operation of the TM1/TM2 must be done by personnel trained and acquainted with the electric motors, power transformers, tap changers on load or voltage regulators, control devices and control circuits of substation equipment.
3. Special attention must be paid to installation of the TM1/TM2, including the type and size of the cables and terminal strips used, as well as the procedures for commissioning, including correct parameterization of the equipment.



The TM1/TM2 must be installed in a sheltered environment (a panel without doors in a control room or in a closed panel, in cases of outdoor installation) where the temperature and humidity specified for the equipment are not exceeded.



If the panel where the TM1 / TM2 was installed has a window , use a G20 film - or higher - to avoid direct incidence of sunlight (UV) at the equipment . Even if the glass of this window is dark, such procedure is necessary.



Do not install the TM1/TM2 near sources of heat like heat resistors, incandescent lamps and devices with high power or with heat dissipaters. Its installation near ventilation orifices or where it can be affected by forced air flow, like outlet or inlet of cooling fans or forced ventilation ducts, is not recommended.



On conducting dielectric strength tests on the wiring (applied voltage), the ground cables connected to terminal 17 of the TM1/TM2 must be disconnected in order to prevent destruction of the protections against overvoltage existing inside the device due to application of high voltages for a long period (e.g.: 2 kV for 1 minute).

Cleaning and decontamination instructions

Take care when cleaning the TM1/TM2. Use ONLY a cloth wet with soap or detergent diluted in water to clean the cabinet, front plate or any other part of the equipment. Do not use abrasive materials, polishers or aggressive chemical solvents (like alcohol or acetone) on any of its surfaces.



Turn off and unplug the equipment before cleaning any of its parts.

Inspection and Maintenance instructions

The following observations must be followed for inspection and maintenance of the TM1/TM2:



Do not open the equipment. In it, there are no parts reparable by the user. This should be done by the Treetech technical assistance, or by technicians accredited by it.

This equipment is completely maintenance-free, being that visual and operational inspections, periodical or not, may be conducted by the user. These inspections are not mandatory.



Opening of the TM1/TM2 at any time will imply in loss of the product warranty. In cases of undue opening of the equipment, Treetech will also not be able to warrant its correct functioning, regardless of the warranty period having expired or not.



All parts of this equipment must be supplied by Treetech, or by one of its accredited suppliers, according to its specifications. If the user wishes to purchase it otherwise, he must strictly follow Treetech's recommendations for this. This way, the performance and safety for the user and the equipment will not be compromised. If these specifications are not followed, the user and the equipment may be exposed to unforeseen and unnecessary risks.

1.5 Technical Assistance

To obtain technical assistance for the TM1/TM2 or any other Treetech product, contact us through the address below:

Treetech Sistemas Digitais Ltda. – Assistência Técnica

Rua José Alvim, 100 – Salas 03 e 04 – Centro

Atibaia – São Paulo – Brazil

Zip Code: 12940-800

CNPJ [Corporate taxpayer's roll]: 74.211.970/0002-53

IE [State Tax ID]: 190.159.742.110

PHONE: +55 (11) 2410-1190 x201

FAX: +55 (11) 2410-1190 x702

Email: suporte.tecnico@treetech.com.br

Site: <http://www.treetech.com.br>

1.6 Warranty term

The Temperature Monitor is guaranteed by Treetech for the term of 2 (two) years, counted from the date of purchase, exclusively against eventual manufacture defects or quality vices that render the equipment unfit for use.

The warranty will not cover damages sustained by the product, as a consequence of accidents, improper handling, incorrect installation and use, inadequate tests or in case the warranty seal has been breached.

The eventual need for technical assistance must be informed to TREETECH, or to a technical assistance service appointed by the same, with the equipment being delivered together with the purchase invoice.

Treetech does not supply, nor is liable to, any other warranty, express or understood, in addition to the ones mentioned above. Treetech does not supply any guarantee of suitability of the TM1/TM2 to any specific application.

The dealer is not liable to any claims for damage to property, nor any other form of losses that might occur, in connection to or stemming from the acquisition of the equipment, of the performance of the equipment or of any other service possibly supplied together with the TM1/TM2.

Under no circumstances will the dealer be made responsible for any losses incurred, included but not limited to: loss of profit or revenue, impossibility in using the TM1/TM2 or any other associated item of equipment, costs of capital, costs of energy acquired, costs of replacement equipment, facilities or services, costs of outages, complaints from clients or employees of the buyer, regardless of whether said damages, complaints or losses are based on contracts, warranties, negligence, felony or any other reason.

Under no circumstances can the dealer be made liable for any personal damage of any sort.

1.7 Revision Control

Table 2 – Revision Control

Revision	Issued	Description	Author
2	2004-11-11	Add submenu PRT (serial communication protocol selection) and review control page. General text revision. Note: This manual version is applied just for Temperature Monitor with firmware V2.0.2	Fco
3	2004-12-08	Included optional functions of forced cooling, clock and calendar, DNP3.0 information. Note: This manual version is applied just for Temperature Monitor with firmware V2.0.4	Fco
4	2005-07-15	Setting range of TRC parameter changed (chapters 5.3.4.1 and 5.3.4.2). Added Modbus registers 67...72. Note: This manual version is applicable only to Temperature Monitor with firmware V2.0.7 and higher (unless a specific manual version is available)	Marcos
5	2006-10-31	Recommendations for insulation tests and parameter sheets included. Revised temperature scale, register maps and troubleshooting. General text revision. Note: This manual version is applicable only to Temperature Monitor with firmware V3.0.0 and higher (unless a specific manual version is available)	Marcos
6	2007-06-01	Optional functions Mass Memory and LTC Temperature Differential included. Note: This manual version is applicable only to Temperature Monitor with firmware V4.0.0 and higher (unless a specific manual version is available)	Marcos
7	2008-04-14	Revised DNP3.0 Device Profile – Analog Inputs 42-49 and Binary Inputs 64-71 included. Revised Modbus Register Map – registers 1025-1031, 1505 and 1506 included. Added figures 4.4.and 4.5. Note: This manual version is applicable only to Temperature Monitor with firmware V4.0.3 and higher (unless a specific manual version is available)	Marcos
8	2008-07-15	Revised Forced Cooling control, chapters 2.2, 3.1, 3.4, 4.1, 4.2, 4.2.4, 4.3, 5.3, 5.3.5, 5.3.5.1, 5.3.5.2, 7.7 and Appendix D. Note: This manual version is applicable only to Temperature Monitor with firmware V4.0.5 and higher (unless a specific manual version is available)	Marcos
9	2013-01-15	Additional functions PBT, SCT, BG1...BG4 included. Some menus were divided in submenus. Note: This manual version is applicable only to Temperature Monitor with firmware V5.0.0 and higher (unless a specific manual version is available)	William Botelho
10	2015-05-21	International Representatives updated	João V. Miranda
11	2015-07-06	New design; parameterization updated; compatible with 4.16 firmware.	João V. Miranda
12	2015-09-17	Procedure for film installation added	João V. Miranda
13	2016-01-20	Figure 26 (Dimensions) Updated	João V. Miranda
14	2016-03-21	Connection Diagram Updated	João V. Miranda

2 Introduction

The Treetech's TM Temperature Monitors form a complete Temperature Monitoring system for transformers and reactors immersed in oil. Designed as a modular system, it can be used in simple, low cost applications, as well as in complete monitoring systems. The system is comprised of modules TM1 and TM2:

- TM1 monitors the temperature of the oil and one winding. The device is equipped with:
 - Configurable input for one 4-lead RTD sensor, for oil temperature, or two 3-lead sensors - redundant reading of oil temperature or simple reading for oil temperature and one additional temperature (e.g.: ambient or LTC);
 - One load current measuring input, for calculating temperature of the winding.
- TM2, applied as complement to TM1, monitors the temperature of one or two additional windings. It is equipped with:
 - Two current measuring inputs, for calculating the temperature of two additional windings;
 - Configurable input for one 4-lead RTD sensor, one 3-lead RTD sensor in input A, one 3-lead RTD sensor in input B or two 3-lead sensors in inputs A and B for reading additional temperatures (e.g.: ambient, LTCs or others).

Além destas funções básicas, estão disponíveis nos monitores TM1 e TM2 diversos opcionais. Vide Funções Opcionais adiante.

2.1 Main Features

- Input for Pt100 ohms at 0°C sensors with self-calibration, precision of 0.2% of the end of scale and high level of stability in a broad range of ambient temperatures.
- Oil temperature measurement using one three-wire Pt100 sensor, one four wire Pt100 or two three-wire Pt100 (redundant temperature measurement and validation of the reading);
- Universal AC current inputs True RMS from 0 to 10A, precision 0.5% of full scale for load measurement and calculation of temperature in the winding through the thermal image process. Optional clip-on current transformers;
- High luminosity, LED type displays for easy visualization, indicating oil, winding and other user selected temperatures;

- Calculation of forecast for final oil-winding temperature gradient for current load condition;
- Current outputs for remote temperature readings, with selection of output range (0...1mA, 0...5mA, 0...10mA, 0...20mA or 4...20mA);
- Selectable cooling system operation via front panel on Automatic or Manual. Automatic alternation in operation of forced cooling groups in pre-programmed stages, based on their operation times , affording uniform use of fans or pumps;
- Optional Pre-cooling function for reducing insulation loss of life due to elevated loads;
- Optional Fan Exercise function for prevention of failures in cooling fans or pumps;
- NO contacts (NC or combinations upon request) for oil or winding temperature alarms;
- NO contacts (NC or combinations upon request) for tripping due to oil and/or winding temperatures with double activation safety (simultaneous order from the 2 micro-controllers for the operation). Adjustable timing between 0 and 20 min with countdown on display;
- NC contacts for activation of forced cooling groups with timer between start up for groups (even with lack of feed for TM1 or TM2) and forced operation resulting from self-diagnosis routines in case of failure or absence of voltage (power outage);
- NC contacts for indication of internal failure or lack of voltage detected in self-diagnosis;
- NO contacts for indication of count down mode for trip activation or alarm by LTC temperature differential;
- Modbus-RTU (standard) or DNP 3.0 (optional) serial communication protocols.
- Protocol DNP-3.0 (optional) with time stamp with 1ms resolution for events like alarms and trips, based on synchronicity by GPS signal clock on standard IRIG-B (only for TM1) or synchronicity by the protocol DNP3.0;
- Non volatile mass memory for storage of temperature readings, alarm or trip events and forced cooling operation;
- Internal clock with settings maintained for 48h in case of failure of power supply. No batteries are used - maintenance-free device.



Figure 1 – Temperature Monitors TM1 and TM2

2.2 Optional Features

According to the order, the TM1/TM2 can be supplied with one or more of the optional features listed below:

Optional 1 – DNP 3.0 protocol:

User selectable communication protocol: Modbus RTU or DNP3.0 level 1. DNP3.0 protocol with support for 1ms resolution time-stamp.

Optional 2 – Pre-Cooling:

Pre-cooling can extend the insulation useful life of transformers subject to overloading by activating cooling groups when user selected load levels are reached. Taking advantage of the large thermal inertia of the oil, the forced cooling systems are activated even before the temperature rises, thus increasing the time required to reach high temperature levels, which would cause accelerated shortening of insulation life cycle. The following parameters are programmed by users:

- Loading percentages for individual activation of up to four cooling stages;
- Hysteresis for shut off of forced cooling stages in case of load reduction.

Optional 3 – Fan and Pump Exercise:

The fan exercise function keeps fans and / or pumps from remaining inactive for prolonged periods of time in transformers operating under low load conditions or during periods of low ambient temperatures. This avoids axle blocking due to accumulation of dirt, grease dry out or bird nesting. Fans are switched on every day, based on the equipment's internal clock and depending on selections made by users:

- Hour and minute for start up of fans and/or pumps;
- Total daily fan and/or pump operation time, from 0 to 999 minutes.

Optional 4 – Temperature Differential for the Load Tap Changer:

Load Tap Changers are one of the main sources of transformer failure. Measuring the temperature difference between the LTC oil and transformer oil may give an indication of a thermal failure event in the equipment before reaching a level of severity that could lead to a major failure. Since this difference is subject to the influence of external variables, monitoring is carried out in two different ways, in order to increase efficiency of diagnosis and avoid false alarms:

- Monitoring of instant difference triggers fast response alarms, in case of high intensity defects, even in case of short duration events;
- Monitoring of difference with long term filter triggers alarms sensitive to permanent defects, even in case of low intensity, with longer detection times.

In three-phase transformers using three single-phase tap changers in separate oil chambers the three temperature differences can be monitored separately.

Optional 5 – Mass Memory:

Nonvolatile memory for storage of temperature readings and alarm events. Users select variable groups to store and save to memory. Recording operation can be started by:

- Time interval between storage of readings selected by user; or
- Variation of temperature higher than any dead band selected by the user, in °C; or
- Change of state in any output relay (control of cooling, alarms, trips or self-diagnostic).

2.3 Operation Philosophy

OIL AND WINDING TEMPERATURES

Based on the readings obtained for the top oil temperature and the load current on the transformer, the temperature monitor calculates the winding temperature by way of the algorithm implemented in its firmware (thermal image). Other data items are part of this algorithm. These other items are programmed in the device by the user, thus adapting the model to each transformer's characteristics.

The oil temperature is measured directly using resistive sensors, type Pt100 Ω at 0°C. The transformer load current measurement is carried out through the secondary of one or more current transformers (CTs) connected directly to the TM1 and TM2 or through external clip-on CTs (optional delivery).

FORCED COOLING CONTROL

Temperature Monitors TM1 and TM2 can command up to 4 forced cooling groups, either in manual or automatic mode. In automatic mode, the control of forced cooling groups is always accomplished based in the higher value measured among oil and 1, 2, and 3 winding temperatures. If the optional pre-cooling function is available, forced cooling can also be commanded based on percentage load of windings, considering the highest measured load. Due to oil and windings thermal inertia, pre-cooling function causes the cooling groups to be activated before transformer achieve the temperature levels preset in automatic command settings, thus reducing the average transformer operating temperature.

Optional function of cooling equipment exercise allows daily activation of fans and/or oil circulation pumps in order to prevent mechanical failures caused by long periods out of service, with user-defined starting time and duration.

LTC TEMPERATURE DIFERENTIAL

The Load Tap Changer (LTC) is one of the principal sources of failure in power transformers, arising mainly from the existence of moving parts that conduct and interrupt high currents while submitted to high electrical potentials.

Some of the most common of these tap changer failure modes are related to the contact deterioration or mechanical wear and tear that give rise to increase in the contact resistance and which in turn raises the temperature significantly and then tends to increase even more the resistance, a cascading effect that leads to complete, severe failure.

Under normal operating conditions, the LTC is a small source of heat compared to the heat generated by the losses of the transformer, in the way that oil temperature in the LTC tank is influenced principally by the transformer's oil temperature. Illustration below, elaborated by real measurements in the field, exemplifies this situation. In it we can observe, as well as the individual transformer and tap changer temperatures, the difference between the LTC temperatures minus the transformer's, which is monitored to detect the faults mentioned above.

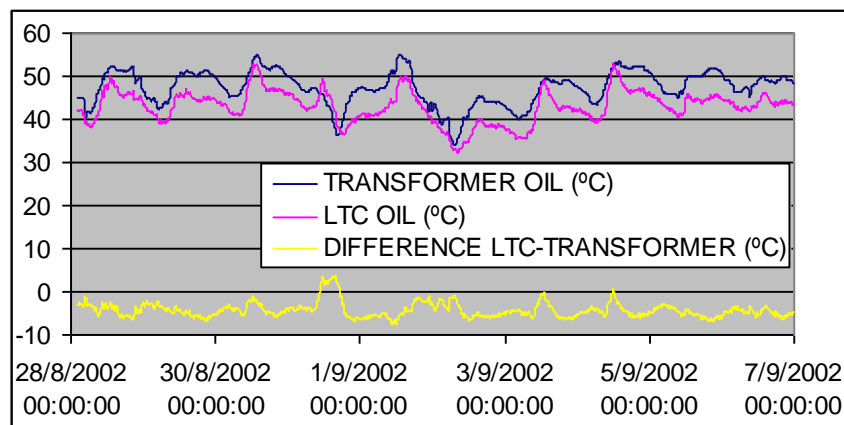

Figure 2 – Temperature measurements of LTC, transformer and temperature differential

As the temperature differential is subject to the influence of external variables, such as the action of forced cooling, rapid variations in atmospheric conditions and others, monitoring is carried out by two distinct modes, illustrated in next figure, in order to increase diagnostic efficiency and avoid false alarms:

- Instantaneous Differential Monitoring - the Instantaneous Temperature Differential monitoring triggers alarms with a rapid response in case there are large-scale faults, even if they have short duration.
- Monitoring of Filtered Differential - the Filtered Temperature Differential is obtained by submitting the Instantaneous Differential to a low-pass filter with user adjustable time-constant. Its monitoring enables the detection of the evolutionary trend of a differential which indicates small permanent defects, over a longer period of detection.

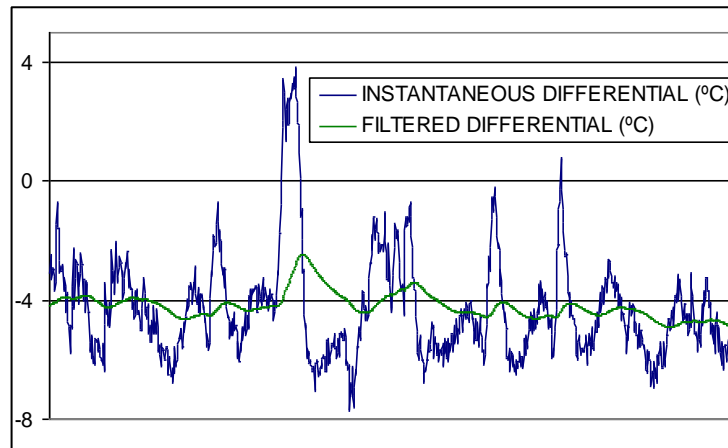

Figure 3 - Instantaneous and Filtered Temperature Differentials

The alarm settings to the monitoring of the Instantaneous and Filtered differentials can be automatically determined by the Temperature Monitor, through a learning period about the normal behavior of the LTC. The automatic alarm settings can be manually changed by user.

The duration of the learning period can be programmed by user. Typical value is one week. During this period the Temperature Monitor will register the peak values for the Instantaneous and Filtered Differentials. After that the alarm settings for both temperature differentials are obtained by summing the peak values to a programmed tolerance margin.

If the measured temperature differentials, either Instantaneous or Filtered, exceed their respective alarm settings the Temperature Monitor will trigger an alarm. This alarm is indicated by a LED lamp on the device's front panel and can operate the output contact A1-A2 on TM1 and/or TM2, provided these contacts are programmed by user in this way.

The measurements of transformer top oil temperature and load tap changer oil temperature are performed by Pt100Ω@0°C sensors, which are connected to the inputs available on Temperature Monitors TM1 and TM2. TM1 has 2 temperature sensor inputs; at least one of them must be used for transformer top oil temperature, the other one can be used for redundant top oil measurement or for LTC, ambient or other temperatures. TM2 has 2 additional inputs available for LTC temperature, ambient temperature or others.

3 Operation

All operations on the Temperature Monitors TM1 and TM2 are performed through the keyboard on the front panel, without the need for any external selector switches. The temperature of the oil, winding (or windings) and Load Tap Changer are shown on the displays, and the alarm status, trips and forced cooling commands are indicated by the signal LEDs.

3.1 Initial Settings

During normal work mode, the Temperature Monitor will display the temperatures of the oil and winding (or windings) connected to the equipment.

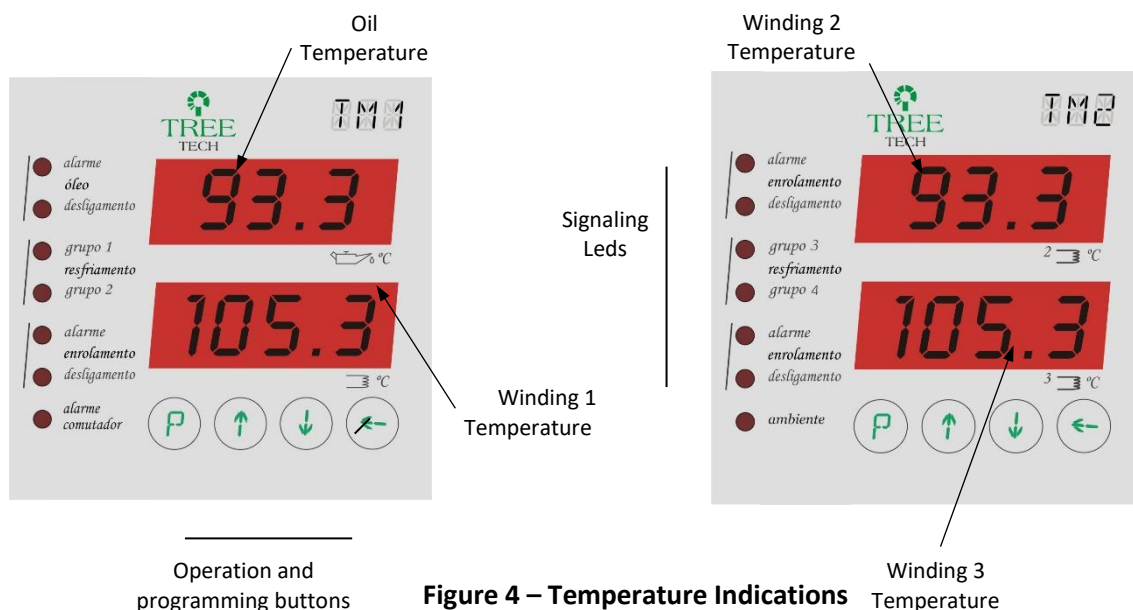

Figure 4 – Temperature Indications

When the value programmed for an event is reached, the corresponding signal LED will light up, and activate the output contact for this event.

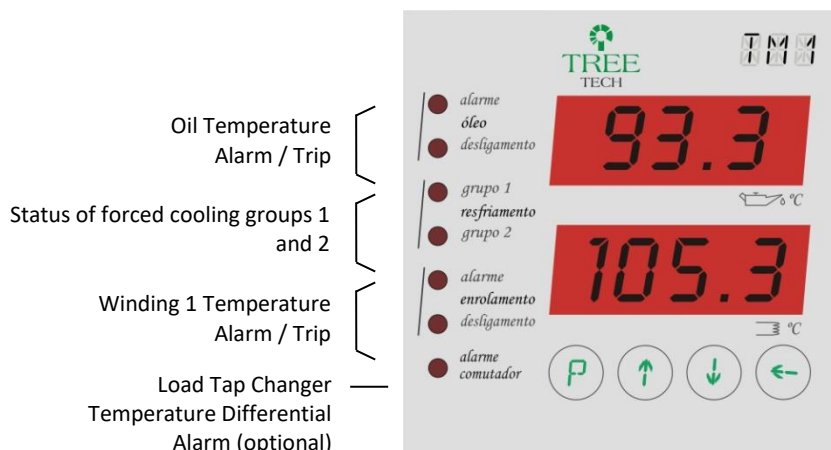

Figure 5 – Signaling LEDs on Temperature Monitor TM1

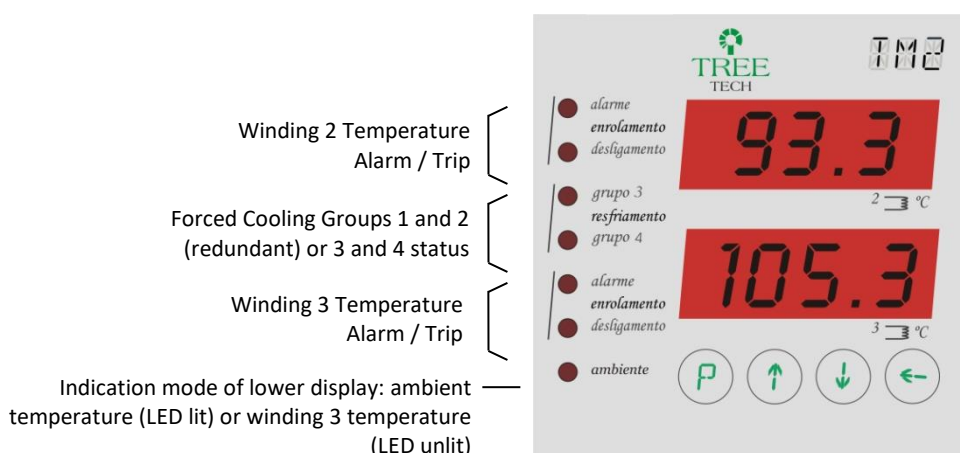

Figure 6 – Signaling LEDs on Temperature Monitor TM2



If selected the PTA or PTB option in the DSP parameter of TM2, the LED indicating the presentation of this temperature instead of winding temperature 3 - which is the standard indication - lights on the front of TM2. This is the signal for the display mode of the lower display, DSP parameter TM2.

In case any abnormality occurs, the corresponding self-diagnostic code will be shown on the displays.

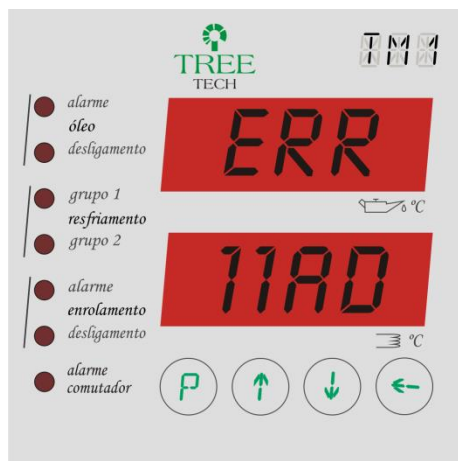





Figure 7 – Self-diagnostic indications

3.2 Function of Keys



 Programming Key: Access to programming menus and advance to next parameter in submenus.

 Up key: menu navigation and increment for programmed values.



 Down key: menu navigation and decrement for programmed values.

 Return key: returns to previous menu.



3.3 Consultation Screens

The Temperature Monitors makes available a set of different information items about the transformer's working situation. This information is accessed through the keys  e  during normal work mode.

TM1 Consultation Screens





The device's displays will exhibit the following information, sequentially by pressing the  key. By pressing the  the data will be displayed in reverse to the order given below:







1) Maximum oil temperature (MAX)

- This is the maximum temperature reached by the oil during the period monitored.
- To reset this reading after consultation, press and hold the  key and press the key : the reading will match the current oil temperature.



2) Maximum temperature of winding 1 (MAX)

- Maximum temperature reached by winding 1 during the period monitored, shown on the lower display.



- To reset this reading after consultation, press and hold the  key and press the key : the reading will match the current temperature for winding 1.
- 3) Final gradient (FTG)**
 - Displays what will be the difference between the temperatures of the oil and winding 1 after thermal stabilization, with the existing load situation remaining unchanged.
 - 4) Percent load of the winding monitored (%)**
 - This is the load on the transformer, given as a percentage of the rated current for the winding being monitored.
 - 5) Current measured on the secondary of the CT (AMP)**
 - This is current on the secondary of the thermal image CT of the winding monitored, given in Amperes.
 - 6) Winding current in kA (kA)**
 - This is the current in the winding of the transformer whose temperature is being monitored, given in kA.
 - 7) Reading of the temperature sensor A connected to TM1 (PTA)**
 - This is the temperature being measured through temperature sensor “A”, given in °C.
 - 8) Reading of the temperature sensor B connected to TM1 (PTB)**
 - The device will only display this information if it has been configured for two sensors (see programming submenu configuration – CNF)
 - This is the temperature being measured through temperature sensor “B”, given in °C, which can be the oil, ambient or other temperature, as programmed on the configuration submenu CNF.
 - 9) Hour indication (HOU).**
 - Internal clock hour indication.
 - 10) Minute indication (MIN).**
 - Internal clock minute indication.
 - 11) Second indication (SEC).**
 - Internal clock second indication.
 - 12) Day indication (DAY).**
 - Internal calendar day indication.
 - 13) Month indication (MON).**
 - Internal calendar month indication.
 - 14) Year indication (YAR).**
 - Internal calendar year indication.
 - 15) Load Tap Changer temperature differential (LTC).**
 - The TM1 will only display this information if it has this optional feature. Press  to access the information regarding LTC minus transformer temperature differential.
 - The device’s displays will exhibit the following information, sequentially by pressing the  key. By pressing the  the data will be displayed in reverse to the order given below:
 - 15.1) TD1** - Instantaneous Temperature Differential of LTC 1.
 - 15.2) TD2** - Instantaneous Temperature Differential of LTC 2.
 - 15.3) TD3** - Instantaneous Temperature Differential of LTC 3.

- 15.4) FD1** - Filtered Temperature Differential of LTC 1.
- 15.5) FD2** - Filtered Temperature Differential of LTC 2.
- 15.6) FD3** - Filtered Temperature Differential of LTC 3.
- 15.7) AAS** – Remaining time to finalize Automatic Alarm Settings for LTC differentials, in hours. The value 0 (zero) indicates the learning process for automatic settings is not in execution.
- 15.8) LTC / MAX** – Maximum values reached by the temperature differentials in the period. Press  to enter the consultation. The device's displays will exhibit the following information, sequentially by pressing the  key. By pressing the  the data will be displayed in reverse to the order given below:
- TD1 / MAX** – Maximum value reached by instantaneous differential of LTC 1.
- TD2 / MAX** – Maximum value reached by instantaneous differential of LTC 2.
- TD3 / MAX** – Maximum value reached by instantaneous differential of LTC 3.
- FD1 / MAX** – Maximum value reached by filtered differential of LTC 1.
- FD2 / MAX** – Maximum value reached by filtered differential of LTC 2.
- FD3 / MAX** – Maximum value reached by filtered differential of LTC 3.
- LT1 / MAX** – Maximum value reached by temperature of LTC 1.
- LT2 / MAX** – Maximum value reached by temperature of LTC 2.
- LT3 / MAX** – Maximum value reached by temperature of LTC 3.
- 15.9) LTC / MIN** – Minimum values reached by the temperature differentials in the period. Press  to enter the consultation. The device's displays will exhibit the following information, sequentially by pressing the  key. By pressing the  the data will be displayed in reverse to the order given below:
- TD1 / MIN** – Minimum value reached by instantaneous differential of LTC 1.
- TD2 / MIN** – Minimum value reached by instantaneous differential of LTC 2.
- TD3 / MIN** – Minimum value reached by instantaneous differential of LTC 3.
- FD1 / MIN** – Minimum value reached by filtered differential of LTC 1.
- FD2 / MIN** – Minimum value reached by filtered differential of LTC 2.
- FD3 / MIN** – Minimum value reached by filtered differential of LTC 3.

Consultation Screen TM2

The following information will be exhibited on the device's displays, sequentially by pressing the  key. If the key  is pressed, the information will be displayed in reverse to the order given below. Information regarding winding 2 and 3 is shown on the upper and lower displays respectively.

1) Maximum temperature in winding 2 (MAX)

- Maximum temperature reached by winding 2, during the period monitored.
- To reset this reading after consultation, press and hold the  key and press the key : the reading will match the current temperature for winding 2.

2) Final gradient for winding 2 (FTG)

- Displays what will be the difference between the temperatures of the oil and winding 2 after thermal stabilization, with the existing load situation remaining unchanged.

3) Percent load of winding 2 (%)

- Load on winding 2, given as a percentage of the rated current for this winding.

4) Current measured on the secondary of the auxiliary CT 2 (AMP)



- Current measured on the secondary of the thermal image CT of the winding 2, given in Amperes.

5) Current in winding 2 in kA (kA)

- Current in the winding 2 of the transformer whose temperature is being monitored, given in kA.

6) Maximum temperature in winding 3 (MAX)

- Maximum temperature reached by winding 3, during the period monitored.

To reset this reading after consultation, press and hold the  key and press the key : the reading will match the current temperature for winding 3.

7) Final gradient for winding 3 (FTG)

- Displays what will be the difference between the temperatures of the oil and winding 3 after thermal stabilization, with the existing load situation remaining unchanged.

8) Percent load of winding 3 (%)

- Load on winding 3, given as a percentage of the rated current for this winding.

9) Current measured on the secondary of the auxiliary CT 3 (AMP)

- Current measured on the secondary of the thermal image CT of the winding 3, given in Amperes.

10) Current in winding 3 in kA (kA)

- Current in the winding 3 of the transformer whose temperature is being monitored, given in kA.



11) Reading of the temperature sensor A connected to TM2 (PTA)

- This is the temperature being measured through temperature sensor “A”, given in °C. The device will only display this information if the input for RTD A on TM2 has been configured for use.





12) Reading of the temperature sensor B connected to TM2 (PTB)

This is the temperature being measured through temperature sensor “B”, given in °C. The device will only display this information if the input for RTD B on TM2 has been configured for use





To check the Firmware version of the TM1/TM2, press  e  simultaneously. The complete number of the firmware version will be shown at the display for 1 second.



3.4 Commands

Through the keys , ,  and  the forced cooling groups 1 to 4 can be manually switched on or left under automatic control.



1) Push momentarily the key 
 TM1 shows the control screen of cooling group CG1

2) Push momentarily key  or  to command CG1 group
 or  to proceed to CG2 group



Cooling group 1 is selected either in manual (ON) or automatic (AUT) mode.

3) Push momentarily key  or  to command CG2 group
 or  to proceed to CG3 group

Cooling group 2 is selected either in manual (ON) or automatic (AUT) mode.

4) Push momentarily key  or  to command CG3 group
 or  to proceed to CG4 group

Cooling group 3 is selected either in manual (ON) or automatic (AUT) mode.

5) Push momentarily the key  or  to command CG4 group or
 to return to normal temperature indication.

Cooling group 4 is selected either in manual (ON) or automatic (AUT) mode.

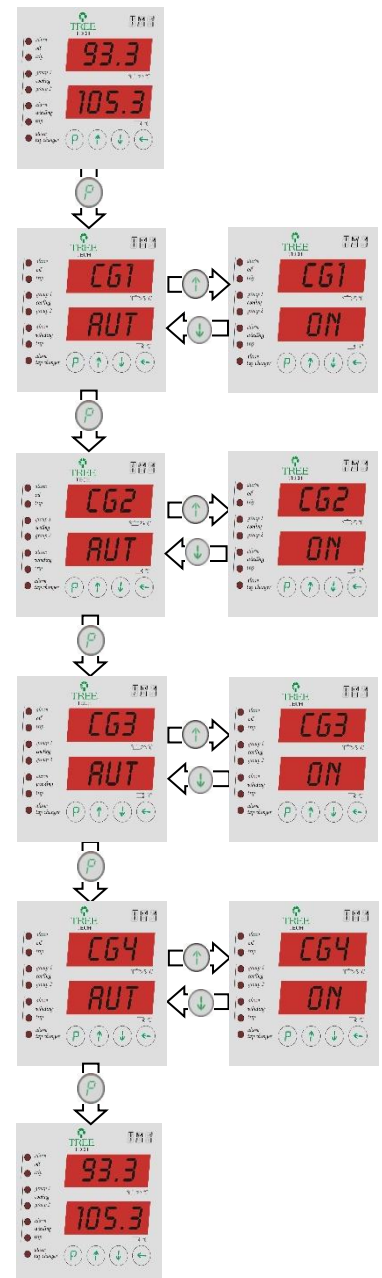

4 Project and Installation

4.1 System Topology

The Temperature Monitoring system is basically composed of:

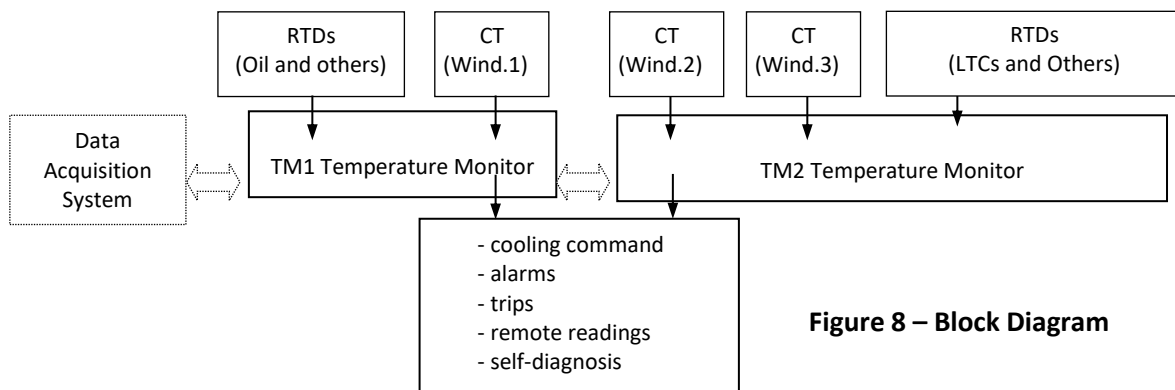

The necessary items for the system are:

- TM1 Temperature Monitor
- RTD Sensor (number and type according to the desired configuration)
- TM2 Temperature Monitor (only if monitoring for more than one winding or measurement of more than 2 RTD sensors are needed)
- Current transformers (Transformer bushing CT)
- 2-way shielded twisted pair for serial communication
- 3 or 4 way shielded cable (according to the connection option adopted) for the RTD connection
- Outdoor installation box (optional)
- External clip-on CTs (optional use).

4.2 Inputs and Outputs

The following inputs and outputs are available on the TM1 and TM2 Temperature Monitors:

Table 3 – TM1/TM2 Inputs

INPUTS	TERMINALS	
	TM1	TM2
1) Auxiliary power feed and ground: Universal power feed input (38 ~ 265 Vdc/Vac, @ 8W, 50/60Hz).	13 – ground 14 – dc/ac 15 – dc/ac	13 – ground 14 – dc/ac 15 – dc/ac
2) RTD input connection on TM1: <ul style="list-style-type: none"> ❖ Allows RTD sensors to be connected using five distinct configurations (see connection option diagrams): ❖ two 3-wire RTDs in redundant configuration to measure top oil temperature; ❖ one 4-wire RTD to measure top oil temperature; ❖ one 3-wire RTD at input A to measure top oil temperature; ❖ one 3-wire RTD at input B to measure top oil temperature. ❖ one 3-wire RTD at input A to measure top oil temperature and one 3-wire RTD at input B to measure another temperature (for instance, ambient or LTC); 	22, 23, 24, A5 and A6	
3) RTD input connection on TM2: Allows connection of RTD sensors using four distinct configurations (see connection option diagrams) to measure additional temperatures, for instance ambient or LTC: <ul style="list-style-type: none"> ❖ one 4-wire RTD; ❖ one 3-wire RTD at input A; ❖ one 3-wire RTD at input B; ❖ two 3-wire RTDs at inputs A and B. 	----	22, 23, 24, A5 and A6
4) Port RS485 TM2: Connection to complementary Temperature Monitor TM2 via shielded twisted pair cable. When the option for protocol DNP3.0 is used with function IRIG-B, which synchronizes equipment clock via GPS, this port is used, so the TM 2 cannot be used.	16 (+) 17 (-)	----
5) Port RS485 TM1: Connection to Temperature Monitor TM1 via shielded twisted pair cable.	----	16 (+) 17 (-)
6) Port RS485 / RS232 - Scada: Connection with data capture system, protocol MODBUS-RTU (standard) or DNP3.0 (optional). The selection of communication port RS485 or RS232 is defined on device's programming.	A7 (+) A8 (-) or Connector DB9 (rear panel)	----
7) Input for CT: Input for direct measurement of the secondary of the bushing CT for thermal imaging or for connection of external clip-on CT.	25 and 26 (CT 1)	25 and 26 (CT 3) 27 and 28 (CT 2)

Table 4 - TM1/TM2 outputs

OUTPUTS	TERMINALS	
	TM1	TM2
<p>1) Saídas em loop de corrente: <i>Duas saídas com positivo comum para indicação remota das temperaturas medidas, programáveis pelo usuário. Padrão de saída selecionado na parametrização (0...1, 0...5, 0...10, 0...20 ou 4...20 mA).</i></p>	18(+) Common 19(-) 20(+) Common 21(-)	18(+) Common 19(-) 20(+) Common 21(-)
<p>2) Alarm relay: <i>Two independent contacts, potential free (NO), triggers alarm due to high temperature of transformer. Pending request, these contacts can be supplied normal closed (NC).</i></p>	1 OIL 2 9 WIND 10	1 OIL 2 9 WIND 10
<p>3) Trip relay: <i>Two independent contacts, potential free (NO), for the transformer protection circuit. These contacts can be programmed to act with timers of up to 20 minutes.</i></p>	3 OIL 4 11 WIND 12	3 OIL 4 11 WIND 12
<p>4) Forced cooling command relays: <i>Two independent dry contacts (NC) in each Temperature Monitor to command up to 4 transformers' forced cooling groups (using TM1 and TM2). When the Temperature Monitors are energized, these contacts change state, returning to the rest position to turn on forced cooling. Pending request, these contacts can be supplied normally open (NO).</i></p>	5 C.G.1 6 7 C.G. 2 8	5 C.G 3 ou 6 C.G. 1 7 C.G. 4 ou 8 C.G..2
<p>5) Self-diagnosis relay: <i>Potential free contact (NC), signals failure in power feed, internal or system failure. When the Temperature Monitor is energized, these contacts change state, returning to the rest position in the event of a failure. Pending request, these contacts can be supplied normally open (NO).</i></p>	A3 and A4	A3 and A4
<p>6) Trip or LTC differential signal relay: <i>Potential free contact (NO), programmable to signal alarm by LTC temperature differentials or trip of transformer - closes instantaneously when trip temperature is reached, signaling trip underway, in case protection contacts are timer controlled. Pending request, these contacts can be supplied normally closed (NC).</i></p>	A1 and A2	A1 and A2

4.3 Project and Installation

Some special care must be followed for TM1 and TM2 project and installation, as described below.



A circuit breaker must be used immediately before the power supply input (Universal supply - 38 ~ 265 Vdc/Vac, <5 W, 50/60 Hz), which corresponds to the pins 14 and 15 of TM1/TM2. This circuit breaker must have a number of poles corresponding to the number of phases used in the supply – being that the poles must interrupt only the phases, and never the neutral or ground – and provide the conductors that supply the equipment with thermal and electrical protection.

The circuit breaker must be near the equipment and easily maneuverable by the operator. It must also

have an indelible identification showing that it is the electrical connection device of the TM1/TM2.



The following circuit breaker specification is recommended, when exclusively for the TM1/TM2:
AC/DC Supply, Phase-Neutral: Single-pole circuit breaker, $1 A \leq I_n \leq 2 A$, curve B or C, NBR/IEC 60947-2, NBR/IEC 60898 or IEEE 1015-2006 standards;
AC/DC Supply, Phase-Phase: Two-pole circuit breaker, $1 A \leq I_n \leq 2 A$, curve B or C, NBR/IEC 60947-2, NBR/IEC 60898 or IEEE 1015-2006 standards.



The minimum insulation for the circuits connected to the TM1/TM2 is 300 V_{rms} for auxiliary equipment and transducers, like Pt-100 and for equipment with own supply with 50 V_{rms}.
The minimum insulation is 1.7 kV_{rms} for equipment supplied with up to 300 V_{rms}, according to IEC EN 61010-1.
These values are related to intrinsic insulation of the devices connected to the TM1/TM2. Cases in which this value does not apply to equipment or devices connected to the TM1/TM2 will be explicitly informed in this manual.

RTD Temperature Sensors

The RTD temperature sensors (oil, ambient, load tap changers or others) must be connected to the Temperature Monitors TM1 and TM2 by way of a shielded cable, without interruption of the shield, which must be grounded only at the end connected to the Temperature Monitor, as close to it as possible. In case intermediate terminal blocks are needed for the RTD sensors, the cable shields should also be connected through the terminal blocks, thus keeping it free of interruption. The unshielded stretch of cable due to the connection should be as short as possible.



The maximum resistance for each one of the used ways at the TM1/TM2's interconnection cable with the Pt-100 is 3Ω. Therefore, 6Ω for the round trip to and from the Pt-100 sensor of the TM1 / TM2.



Considering the maximum allowed resistance in the connection between the Pt-100 and the TM1 / TM2, we have that for a copper cable with 1.5 mm² gauge, the Pt-100 can be installed at a maximum distance of 265 m from the TM1 / TM2. Other values are possible with the correct sizing of cable. If you need support for cable sizing, please contact the Treetech Application Engineering.

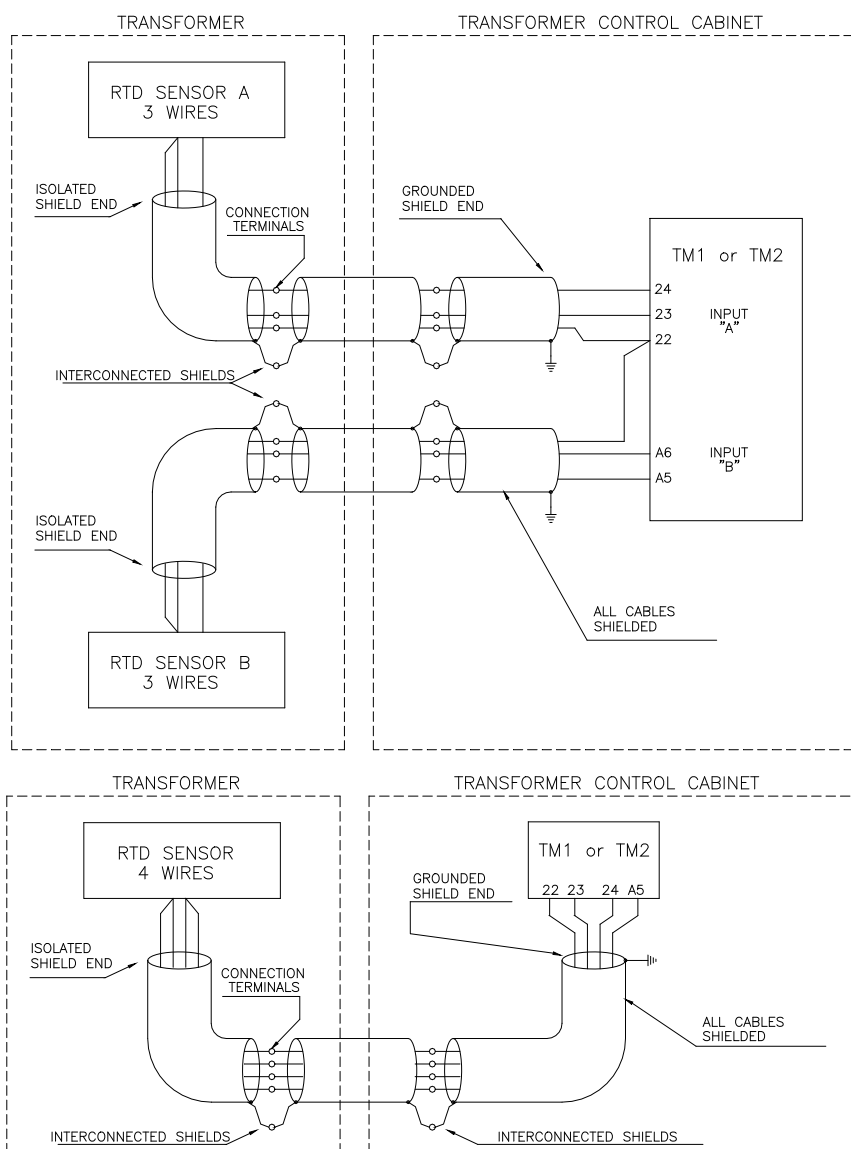

Figure 9 – Detail Shield Connection of RTD Sensor

Serial Communication Ports RS485

Serial communication (RS485) between the Temperature Monitors TM1 and TM2 must be linked by way of a shielded twisted pair cable, keeping the shield uninterrupted all the way to its specific input at the devices, with only one of the ends being grounded. The same cares must be taken in connecting the serial connection (RS485) of the TM1 Temperature Monitor to a Data Acquisition system, bearing in mind that the maximum admissible distance for this type of communication is 1300 meters.

In case intermediate terminal blocks are needed for the serial RS485 communication link, the cable shield should also be passed by the terminal blocks, thus keeping it free of interruption. The unshielded stretch of cable due to the connection should be as short as possible.

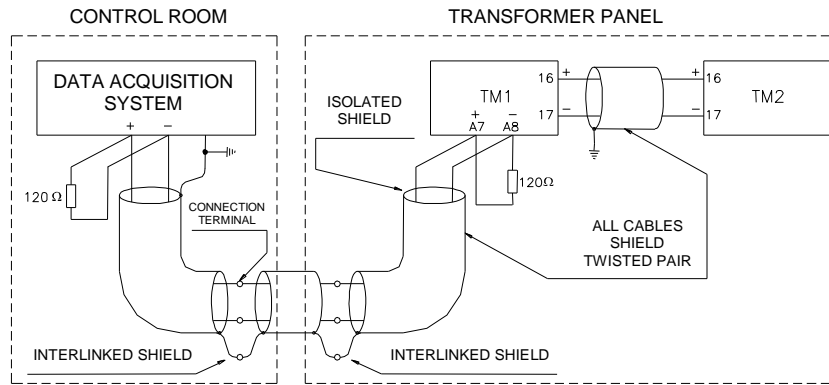

Figure 10 – Shield connection of serial communication

Analogic Outputs

The analogic signal circuit - mA output - should be connected through a shielded twisted pair cable, keeping the mesh without interruption until his termination on the specific input of the equipment grounding only one end.

In case intermediate terminal blocks are needed for the mA outputs communication link, the cable shield should also be passed by the terminal blocks, thus keeping it free of interruption. The unshielded stretch of cable due to the connection should be as short as possible.



The two outputs relating to pins 18 and 20 are interconnected, resulting in a positive common.



The use of unsuitable cables for RS-485 communication and mA output can compromise the performance of TM1 / TM2.

Always use the recommended cables.

Current Transformers

Current transformer connections must be performed according to the model of Temperature Monitor specified:

- For direct connection of thermal image CT secondaries (0-10A) to the Temperature Monitors; or
- For connection using external clip-on (split-core) CTs.

In both cases, due care must be taken to avoid opening thermal image CT secondaries, making sure that the transformer is de-energized or the CT terminal blocks are short-circuited and grounded during system installation or maintenance.

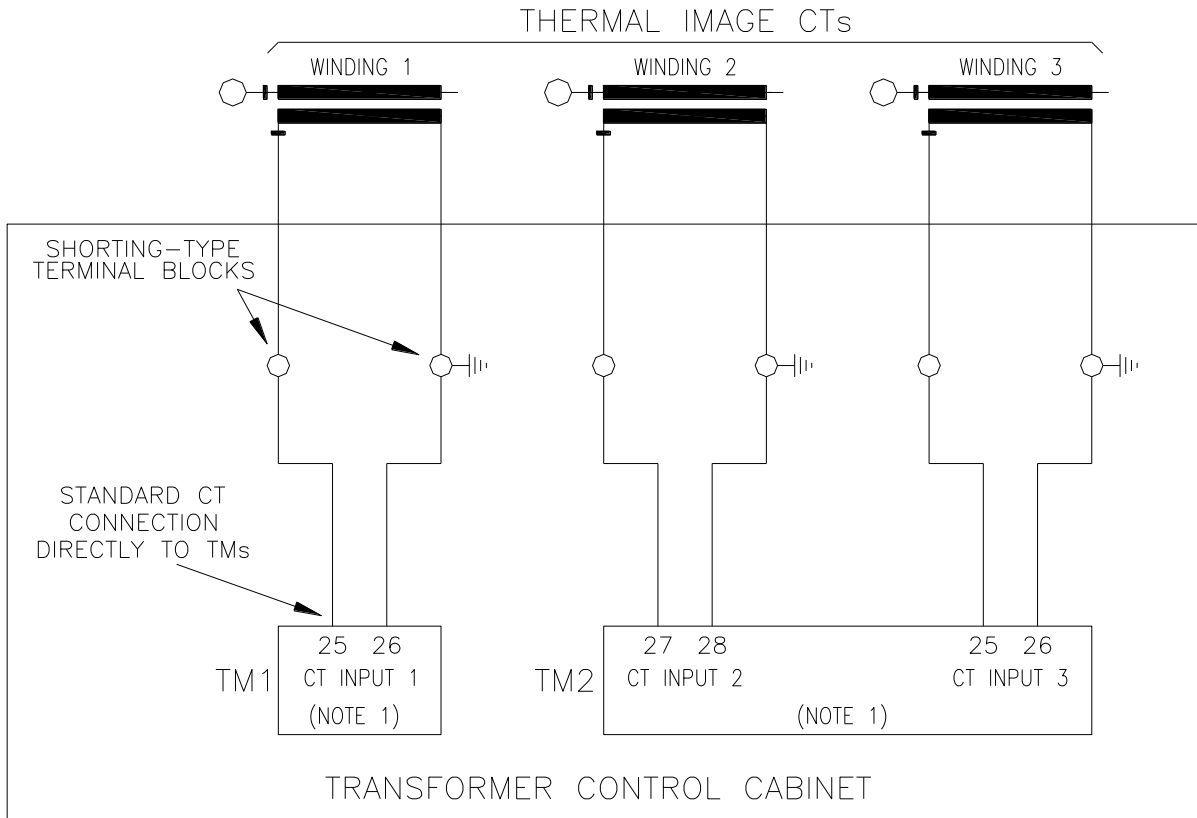

NOTE 1: TM1 AND TM2 MUST BE SPECIFIED AT ORDER FOR DIRECT CT SECONDARY (0-10A) CONNECTION.

Figure 11 – Connection details of current transformers directly Temperature Monitors

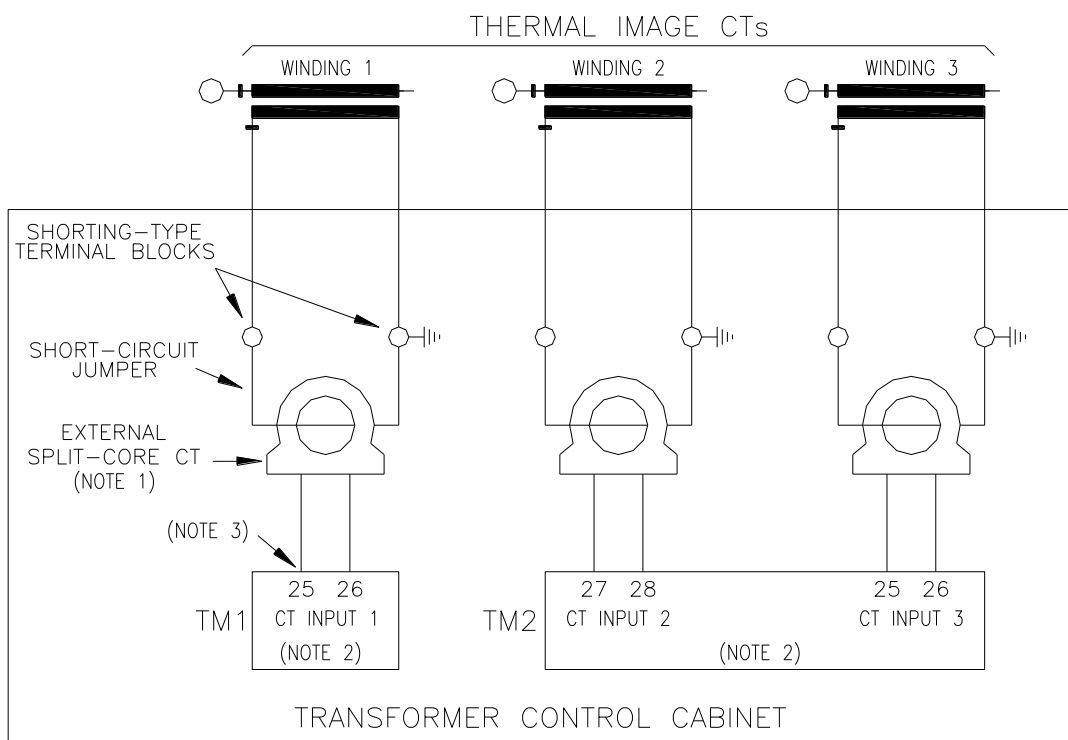

- NOTE 1: OPTIONAL DEVICE PROVIDED BY TREETECH.
 NOTE 2: TM1 AND TM2 MUST BE SPECIFIED AT ORDER FOR USE WITH EXTERNAL SPLIT-CORE CT.
 NOTE 3: DO NOT CONNECT THERMAL IMAGE CTs DIRECTLY TO A TEMPERATURE MONITOR PREPARED FOR USING EXTERNAL SPLIT-CORE CTs. RISK OF PERSONNEL INJURY OR EQUIPMENT DAMAGE DUE TO CT SECONDARY OPENING.

Figure 12 – Connection details of current transformers to Temperature Monitors prepared for external clip-on CTs

Forced Cooling Control

Each Temperature Monitor TM1 and TM2 has two independent and free of potential NC contacts, to command from 1 to 4 forced cooling groups, as defined by the user. Groups 1 and 2 are controlled by TM1 contacts 5-6 and 7-8, and groups 3 and 4 by TM2 contacts 5-6 and 7-8, respectively. When energizing Temperature Monitors, these contacts change their statuses and return to home position to activate cooling. Under request, they can be supplied normally open (NO). Preset forced cooling operation is divided in 4 Cooling Stages. At each Stage, its operation temperature (and load percentage for operation, in case the optional pre-cooling is available) and the Cooling Groups enrolled and available for use in this Stage are preset. Table below shows an example of Cooling Stage presets:

Cooling Stage	Activation Temperature	Cooling Groups			
		CG 1	CG 2	CG 3	CG 4
CS1	FC1 = 60°C	YES	YES	NO	NO
CS2	FC2 = 65°C	YES	YES	NO	NO
CS3	FC3 = 70°C	NO	NO	YES	YES
CS4	FC4 = 75°C	NO	NO	YES	YES

When a given Stage activation temperature is reached, only one of its enrolled Cooling Groups will be activated (the groups enrolled in that Stage are those selected as "YES".) The selection of which Group will be activated is based on Groups' working times: the one showing the lowest working time will be chosen. Similarly, whenever the temperature falls below the Stage deactivation value, only one among those Cooling Groups which are on and enrolled in that Group will be turned off. The selection of which Group will be deactivated is based on Groups' working times: the one showing the highest working time will be chosen. So that there is a tendency the Cooling Groups have equal working times, thus preventing an excessive wear and tear of a group in comparison to the others.

Following are shown some examples of the different possible applications for the TM1/TM2 forced cooling control with the respective configurations

Example 1 – Four equal Cooling Groups with stepped activation temperatures

In this example, as the 4 groups are equal, it is desirable the group activation is shifted as the measured temperature raises. Otherwise, in case the groups' activation sequence is fixed, the activated groups with lower temperature could show a significantly higher wear and tear in comparison to others. In order to achieve total shift among the 4 groups, all of them are enrolled (and selected as "YES") in all Cooling Stages.

As example, let's say groups 1 to 4 have the following accumulated operation times: 1034, 1056, 993, and 1042 hours, respectively. When winding temperature raises and reaches 60°C, among the Groups enrolled in Stage 1 (Groups 1, 2, 3 and 4) the one having the lowest operation time will be activated, Group 3 in this case. When winding temperature reaches 65°C, among the Groups enrolled in Stage 2 and which are not yet in operation, the one having the lowest operation time will be activated, Group 1 in this case. Similarly, at 70°C Group 4 will be activated and at 75°C, Group 2.

Continuing from the previous example, let's say that after some time working with temperature above 75°C, the accumulated operation times for groups from 1 to 4 are: 1042, 1060, 1003, and 1048 hours, respectively. Assuming yet a hysteresis adjustment of 1°C, when winding temperature falls below 74°C, among those Groups enrolled in Stage 4 and which are in operation, the one having the higher operation time will be deactivated, Group 2 in this case. When winding temperature falls below 69°C, among the Groups enrolled in Stage 3 and which are still in operation, the one having the highest operation time will be deactivated, Group 4 in this case. Similarly, below 64°C Group 1 will be deactivated and below 59°C, Group 3.

EXAMPLE 1: FOUR SIMILAR FORCED COOLING GROUPS

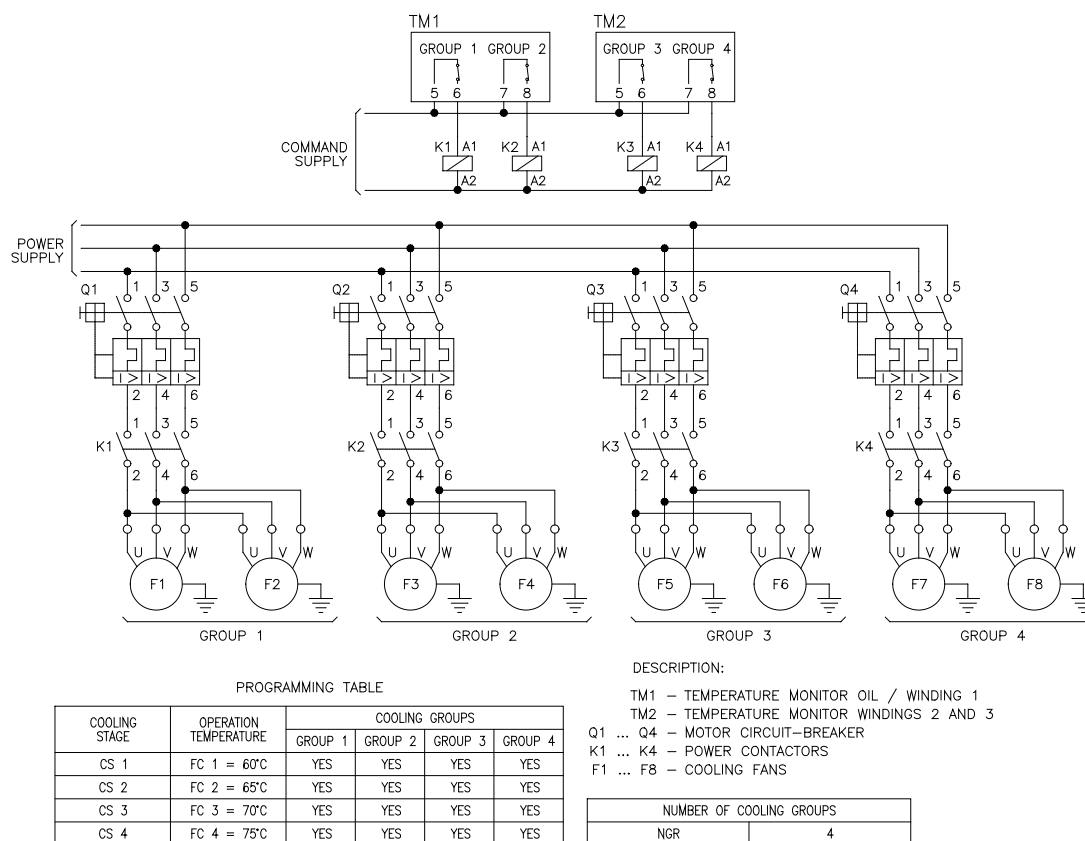

Figure 13 – Command of 4 equal forced cooling groups shifting the operation of groups

Example 2 – One Cooling Group with Oil Pumps and Three equal Cooling Groups with Fans having stepped activation temperatures

In this example, as Group 1 is different from Groups 2 to 4, which in their turn are equal to each other, Group 1 should not be shifted to other groups, and it is desirable that Groups 2, 3 and 4 are shifted. For this purpose, only Group 1 is enrolled (selected as “YES”) in Cooling Stage 1, and in order to groups 2, 3 and 4 are shifted, they are enrolled in Cooling Stages 2, 3 and 4.

As example, let's say groups 1 to 4 have the following accumulated operation times: 2011, 1245, 1191, and 1187 hours, respectively. When winding temperature raises and reaches 60°C, Group 1, which is the only one enrolled in Stage 1, will be mandatorily activated. When winding temperature reaches 65°C, among the Groups enrolled in Stage 2 (Groups 2, 3 and 4), the one having the lowest operation time will be activated, Group 4 in this case. When winding temperature reaches 70°C, among the Groups enrolled in Stage 3 and which are not yet in operation, the one having the lowest operation time will be activated, Group 3 in this case. Similarly, at 75°C, Group 2 will be activated.

Continuing from the previous example, let's say that after some time working with temperature above 75°C, the accumulated operation times for groups from 1 to 4 are: 2022, 1249, 1196, and 1197 hours, respectively. Assuming yet a hysteresis adjustment of 1°C, when winding temperature fall below 74°C, among those Groups enrolled in Stage 4 and which are

in operation, the one having the higher operation time will be deactivated, Group 2 in this case. When winding temperature falls below 69°C, among the Groups enrolled in Stage 3 and which are still in operation, the one having the highest operation time will be activated, Group 4 in this case. Similarly, below 64°C Group 3 will be deactivated and below 59°C, Group 1, which is the only one enrolled in Stage 1, will be deactivated.

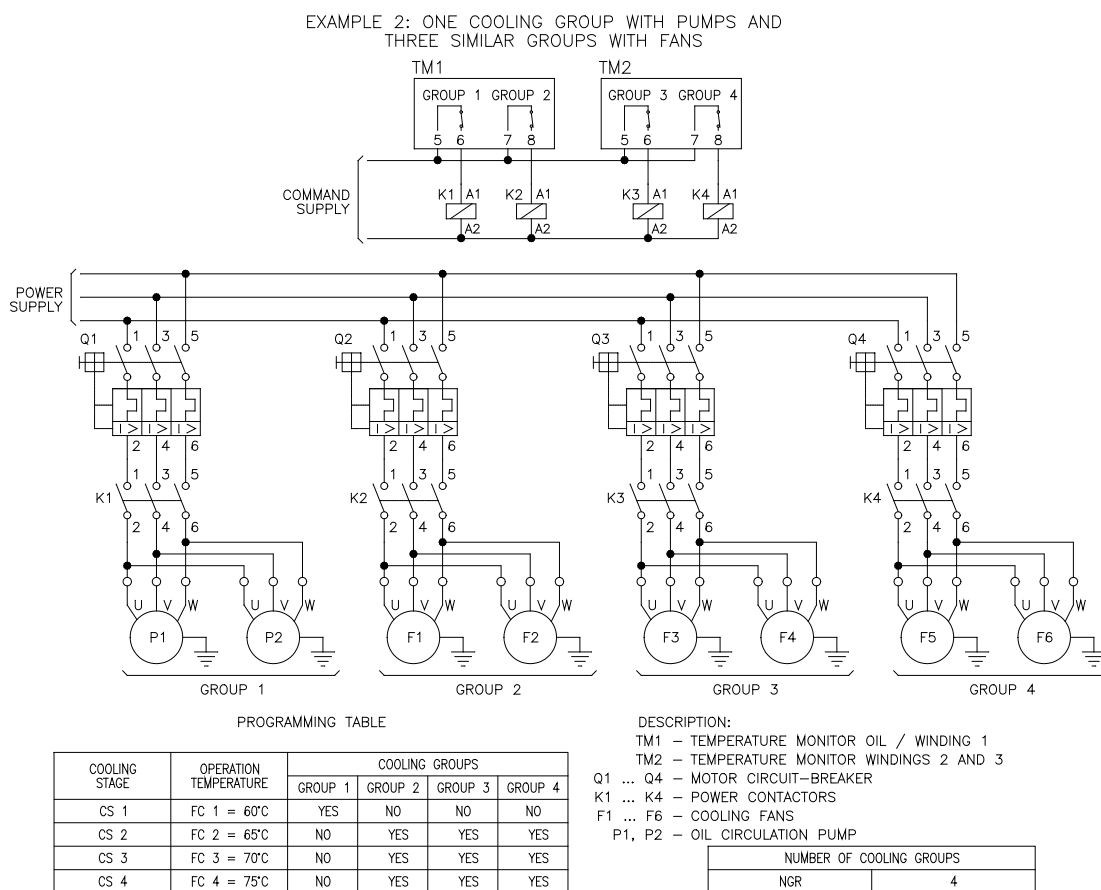

Figure 14 – Command of 1 forced cooling group with pumps and 3 equal groups with fans shifting the operation of fan groups

Example 3 – Two equal Cooling Groups with pumps and two equal Groups with fans having stepped activation temperatures

In this example, Groups 1 and 2 are equal to each other and different from Groups 3 and 4, which in their turn are equal to each other. So that no shift of Groups 1 and 2 with Groups 3 and 4 is required, however it is desirable a shift between Groups 1 and 2 and another independent shift between Groups 3 and 4. For this purpose, only Groups 1 and 2 are enrolled (selected as “YES”) in Cooling Stages 1 and 2, and Groups 3 and 4 are enrolled in Cooling Stages 3 and 4.

As example, let's say groups 1 to 4 have the following accumulated operation times: 1803, 1798, 1501, and 1509 hours, respectively. When winding temperature raises and reaches 60°C, among the Groups enrolled in Stage 1 (Groups 1 and 2) the one having the lowest operation

time will be activated, Group 2 in this case. When winding temperature reaches 65°C, among the Groups enrolled in Stage 2 and which are not yet in operation, the one having the lowest operation time will be activated, Group 1 in this case. When winding temperature reaches 70°C, among the Groups enrolled in Stage 3 and which are not yet in operation, the one having the lowest operation time will be activated, Group 3 in this case. Similarly, at 75°C, Group 4 will be activated.

Continuing from the previous example, let's say that after some time working with temperature above 75°C, the accumulated operation times for groups from 1 to 4 are: 1809, 1810, 1505, and 1512 hours, respectively. Assuming yet a hysteresis adjustment of 1°C, when winding temperature falls below 74°C, among those Groups enrolled in Stage 4 and which are in operation, the one having the higher operation time will be deactivated, Group 4 in this case. When winding temperature falls below 69°C, among the Groups enrolled in Stage 3 and which are still in operation, the one having the highest operation time will be deactivated, Group 3 in this case. Similarly, below 64°C Group 1 will be deactivated and below 59°C, Group 2.

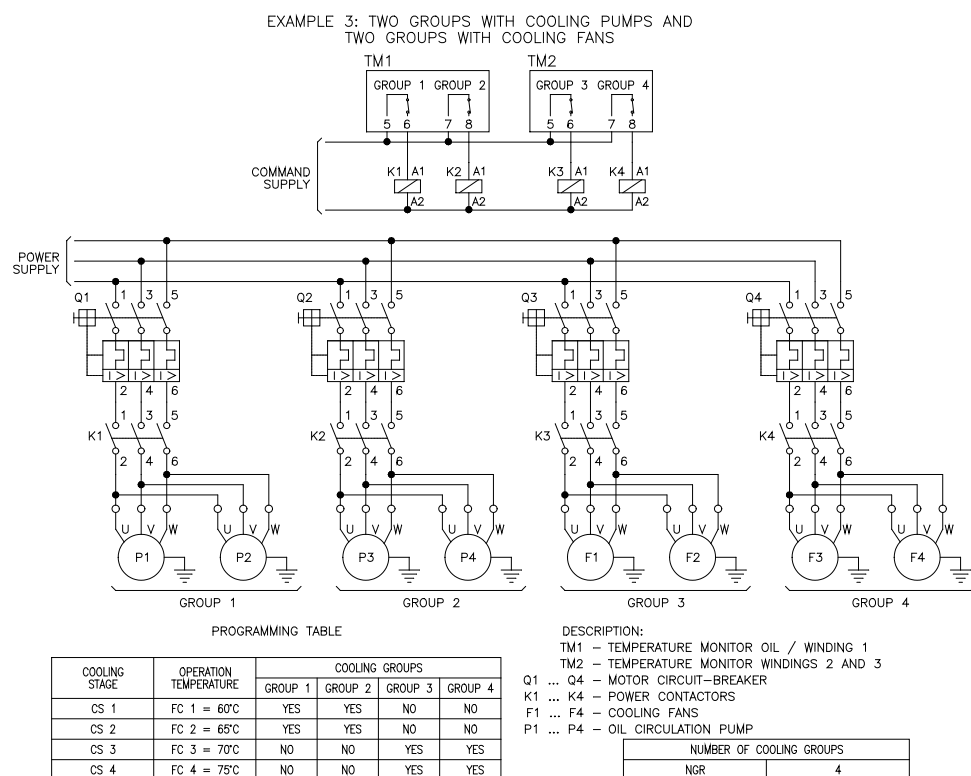

Figure 15 – Comman of 2 equal forced cooling groups with pumps and 2 equal groups with fans, with independente shifting for the operation of the pump groups and the fan groups

Example 4 – Four equal Cooling Groups, with motor start timer

In this example, the Cooling Stages have to be activated in only 2 different steps, 60°C and 65°C. However, in order to reduce the current peak due to motors ignition, the fans were divided in 4 equal cooling groups, so that when any of the temperature steps is reached one group is promptly activated, and after 10 seconds, another one is activated.

In order to shift fans activation, Cooling Stages 1 and 2 are programmed with the same activation temperature, however only Groups 1 and 2 are enrolled (selected as “YES”) in Stage 1 and Groups 3 and 4 are enrolled in Stage 2. Similarly, Stages 3 and 4 are programmed with the same activation temperature, only Groups 1 and 2 are enrolled in Stage 3, and Groups 3 and 4 are enrolled in Stage 4.

As an example, let's say that groups 1 to 4 have the following accumulated operation times: 500, 503, 500, and 503 hours, respectively. When winding temperature raises and reaches 60°C, among the Groups enrolled in Stage 1 (Groups 1 and 2) the one having the lowest operation time will be activated - Group 1 in this case - and after 10 seconds, among the Groups enrolled in Stage 2 (Groups 3 and 4), the one having the lowest operation time will be activated, Group 3 in this case. When winding temperature reaches 65°C, among the Groups enrolled in Stage 3 and with are not in operation, the one having the lowest operation time will be activated - Group 2 in this case - and after 10 seconds, among the Groups enrolled in Stage 4 (Groups 3 and 4) and which are not in operation, the one having the lowest operation time will be activated, Group 4 in this case.

Continuing from the previous example, let's say that after some time the temperature falls below 59°C and all cooling groups are deactivated, now being the accumulated operation times for groups from 1 to 4: 509, 508, 509, and 508 hours, respectively. When winding temperature raises and reaches 60°C, among the Groups enrolled in Stage 1 (Groups 1 and 2) the one having the lowest operation time will be activated - Group 2 in this case - and after 10 seconds, among the Groups enrolled in Stage 2 (Groups 3 and 4), the one having the lowest operation time will be activated, Group 4 in this case. When winding temperature reaches 65°C, among the Groups enrolled in Stage 3 and with are not in operation, the one having the lowest operation time will be activated - Group 1 in this case - and after 10 seconds, among the Groups enrolled in Stage 4 (Groups 3 and 4) and which are not yet in operation, the one having the lowest operation time will be activated, Group 3 in this case.

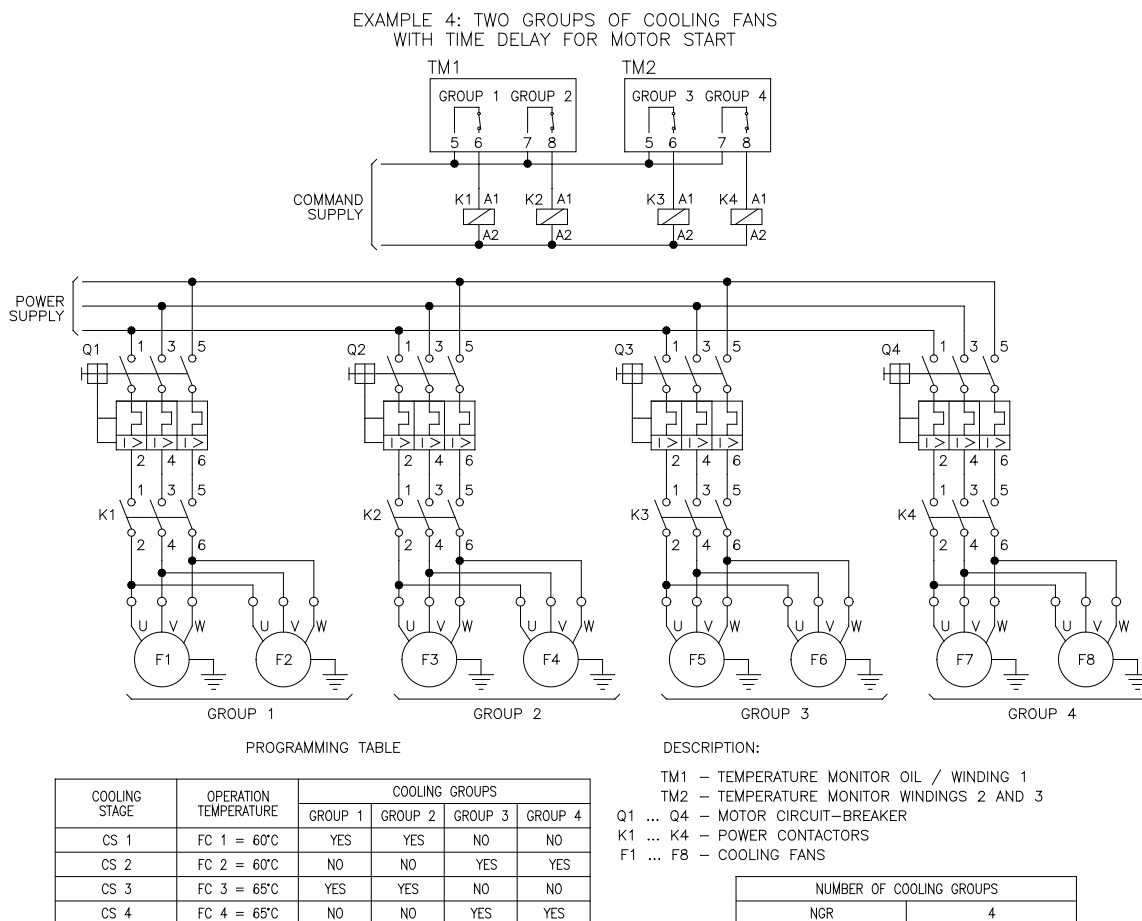

Figure 16 – Command of 4 equal forced cooling groups in 2 temperature stages, with timer for motors start and shifting the groups

In transformers with only two cooling groups, TM2 contacts are used to control redundantly groups 1 and 2 and should be connected in parallel with the contacts of TM1.

Example 5 – Two equal Cooling Groups, with redundancy of cooling control

In this example, the Cooling Stages have to be activated in only 2 different steps, 60°C and 65°C. However, as the motors ignition timer is not required, only 2 Cooling Groups are used, and TM2 contacts are used to redundantly control Groups 1 and 2, which have to be connected in parallel with TM1 contacts. In order to shift the 2 groups activation, both are enrolled (selected as “YES”) in two Cooling Stages.

As an example, let's say that groups 1 and 2 have the following accumulated operation times: 645 and 648 hours, respectively. When winding temperature raises and reaches 60°C, among the Groups enrolled in Stage 1 (Groups 1 and 2) the one having the lowest operation time will be activated, Group 1 in this case. When winding temperature reaches 65°C, among the Groups enrolled in Stage 2 and which are not yet in operation, the one having the lowest operation time will be activated, Group 2 in this case.

Continuing from the previous example, let's say that after some time the temperature falls below 59°C and all cooling group are deactivated, now being the accumulated operation

times for groups 1 and 2: 651 and 650 hours, respectively. When winding temperature raises and reaches 60°C, among the Groups enrolled in Stage 1 (Groups 1 and 2) the one having the lowest operation time will be activated, Group 2 in this case. When winding temperature reaches 65°C, among the Groups enrolled in Stage 2 and which are not yet in operation, the one having the lowest operation time will be activated, Group 1 in this case.

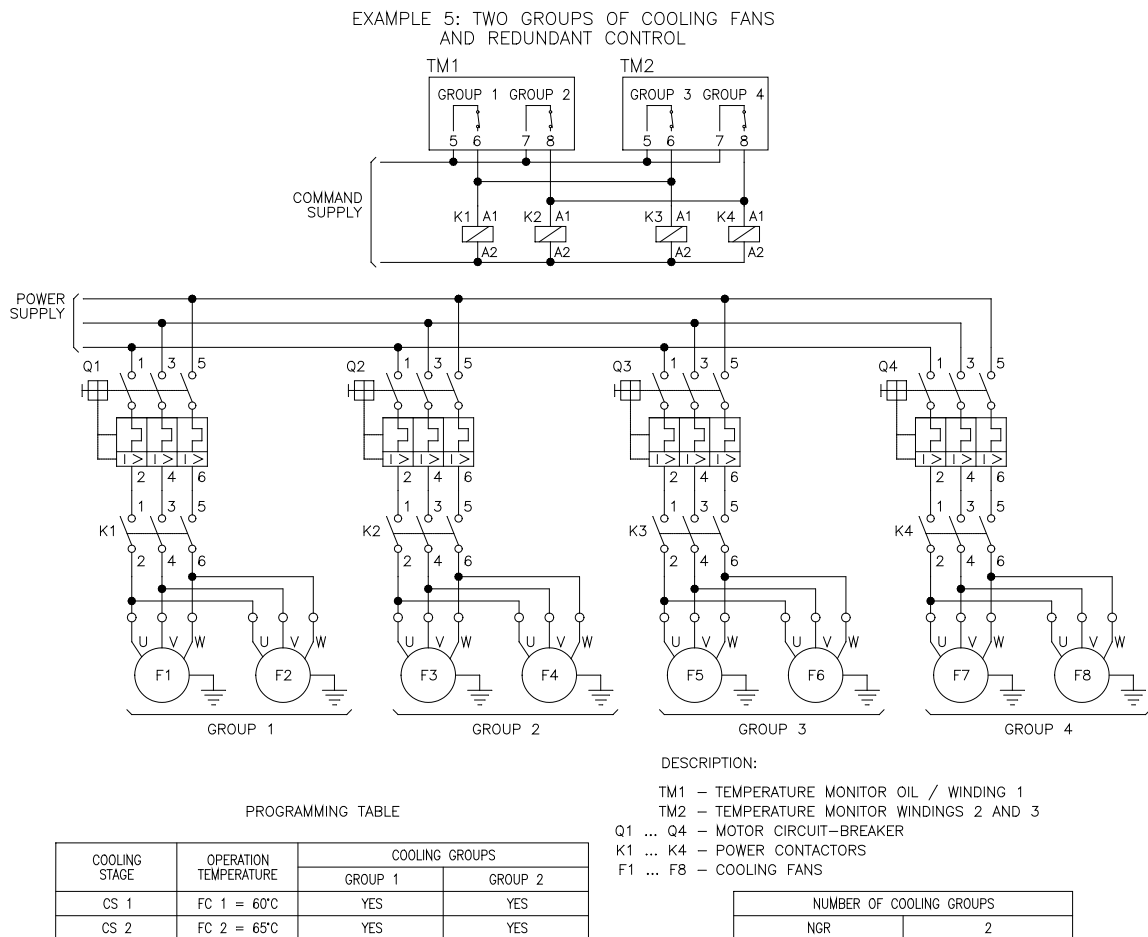

Figure 17 – Command of 2 equal forced cooling groups with command redundancy

4.4 Typical Application Diagrams

RTD Sensors – Option 1

OPTION 1

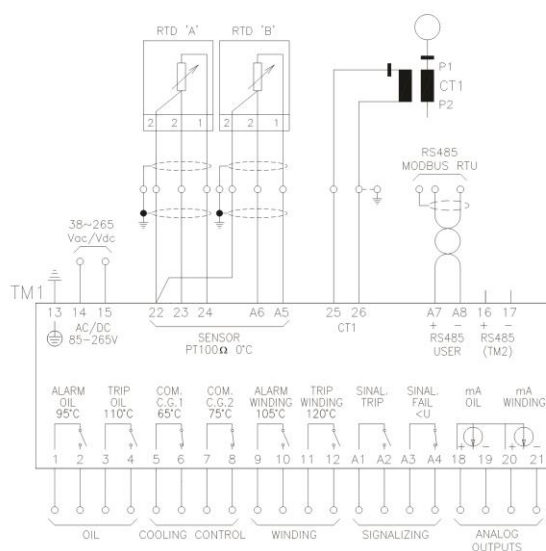
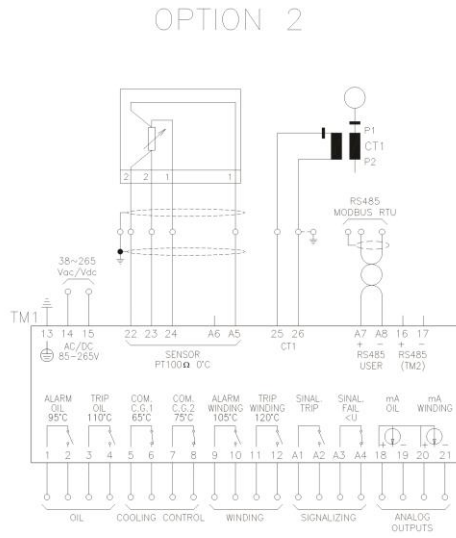

Figure 18 – Option 1 – 2 RTDs with 3 wires

This connection option can be used for:

- Redundant measurement of top oil temperature – in this case both temperature sensors A and B must be located in the same top oil region; or
- Top oil temperature measurement with sensor A and a second temperature, for instance ambient or load tap changer with sensor B.

RTD Sensors - OPTION 2



At this connection option, the sensor must be used for top oil temperature measurement.

Figure 19 - Option 2 – 1 RTD with 4 wires

RTD Sensors - OPTION 3

OPTION 3

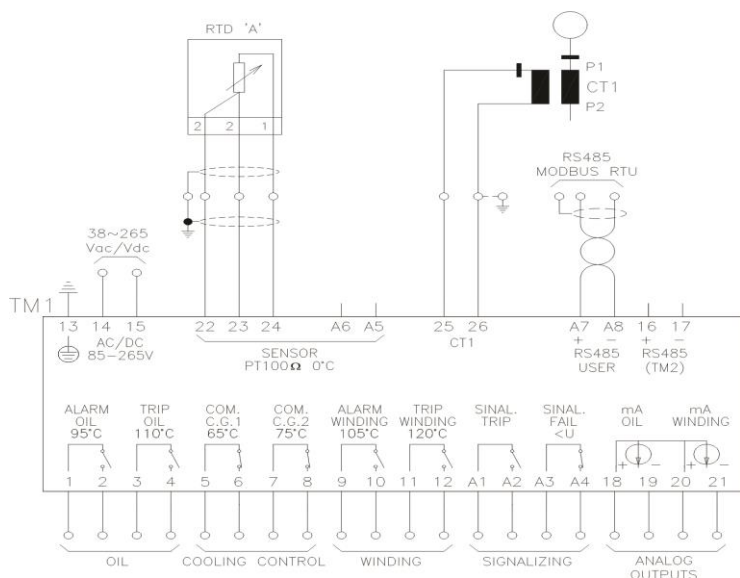

Figure 20 – Option 3 – 1 RTD with 3 wires, RTD A

At this connection option the temperature sensor B must be used for top oil temperature measurement.

RTD Sensors - OPTION 4

OPTION 3

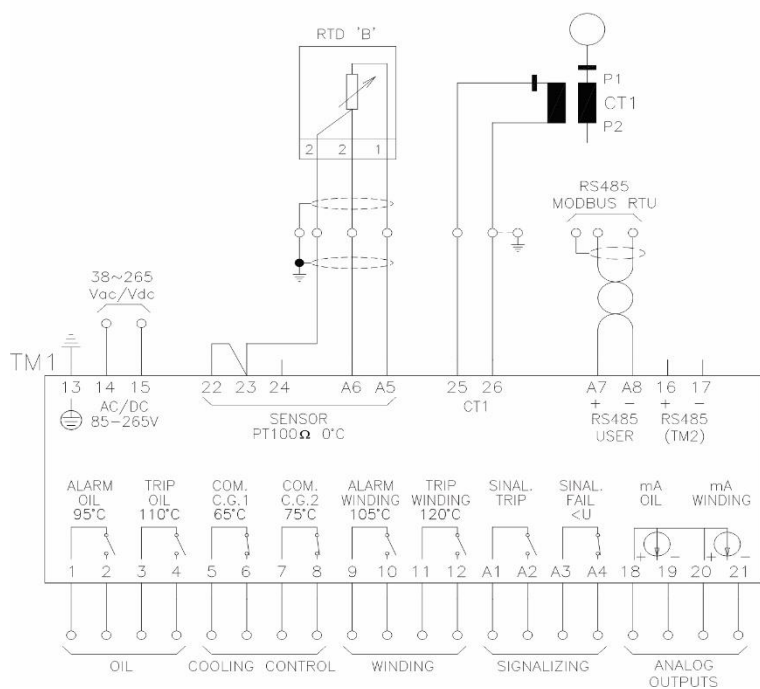
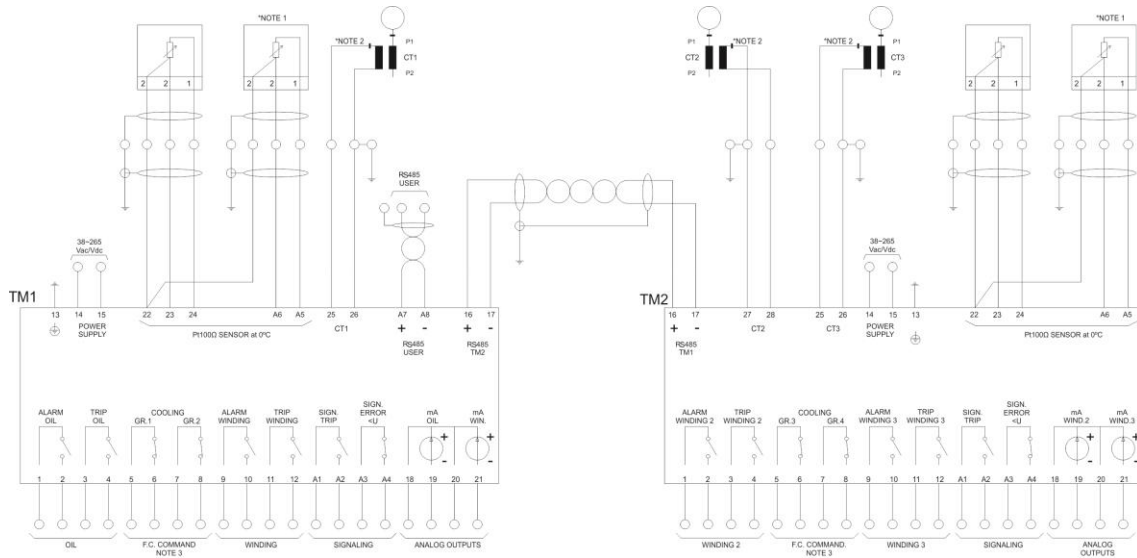

Figure 21 – Option 4 – 1 RTD with 3 wires, RTD B

At this connection option the temperature sensor B must be used for top oil temperature measurement.



*NOTE 1: SEE RTD SENSOR CONNECTION OPTIONS. THE TOP OIL TEMPERATURE MEASUREMENT (1 OR 2 SENSORS) MUST BE CONNECTED TO TM1. OTHER RTD SENSORS INPUTS AT TM1 AND TM2 MAY BE USED BY THE USER.

*NOTE 2: CONNECTION OF TCs MUST BE MADE IN ACCORDANCE WITH THE TEMPERATURE MONITOR MODEL PURCHASED. FOR DIRECT CONNECTION OF TCs 9-0-10A OR USE TCs 9 EXTERNAL BOX (OPTIONAL ACCESSORIES) SEE TECHNICAL MANUAL FOR CONNECTION DETAILS.

*NOTE 3: THE COOLING CONTROL CONTACTS IN TM2 MAY BE EMPLOYED AS REDUNDANCY TO THE TM1'S, CONNECTING IN PARALLEL FOR THE CONTROL OF 2 GROUPS OF COOLING.

*NOTE 4: ALL CONTACTS ARE SHOWN IN CONDITION OF TM1 AND TM2 DE-ENERGIZED

Figure 22 – Connection TM1/TM2

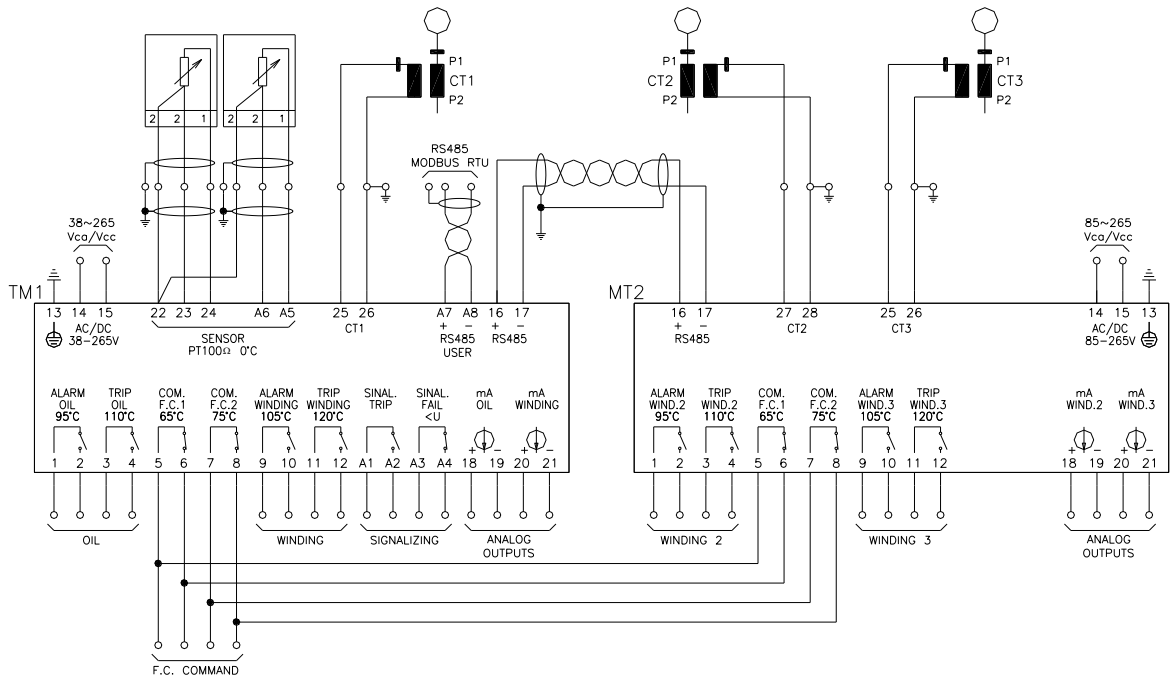

Figure 23 – Connection TM1 / MT2

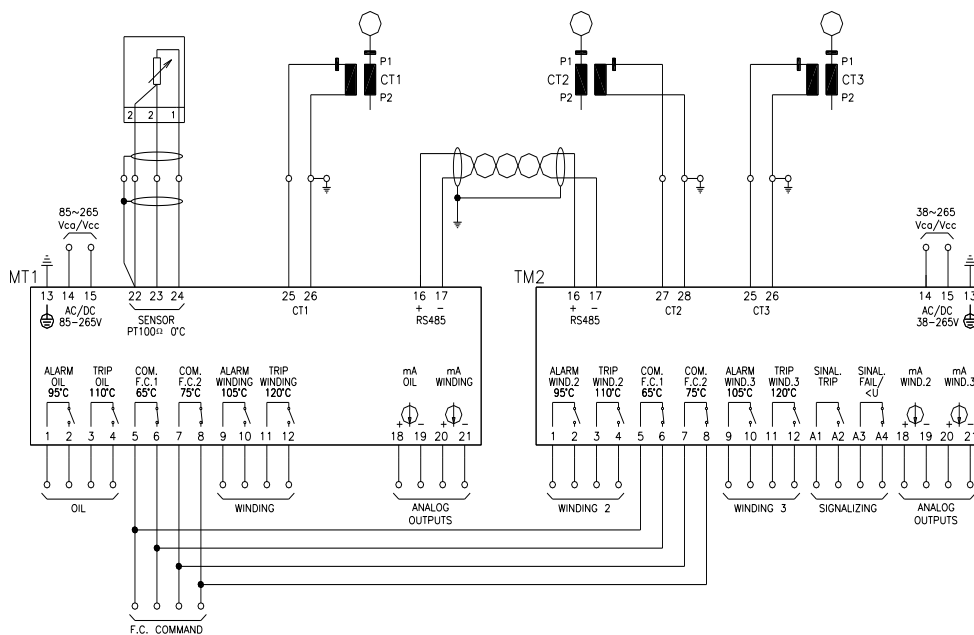

Figure 24 – Connection MT1 / TM2

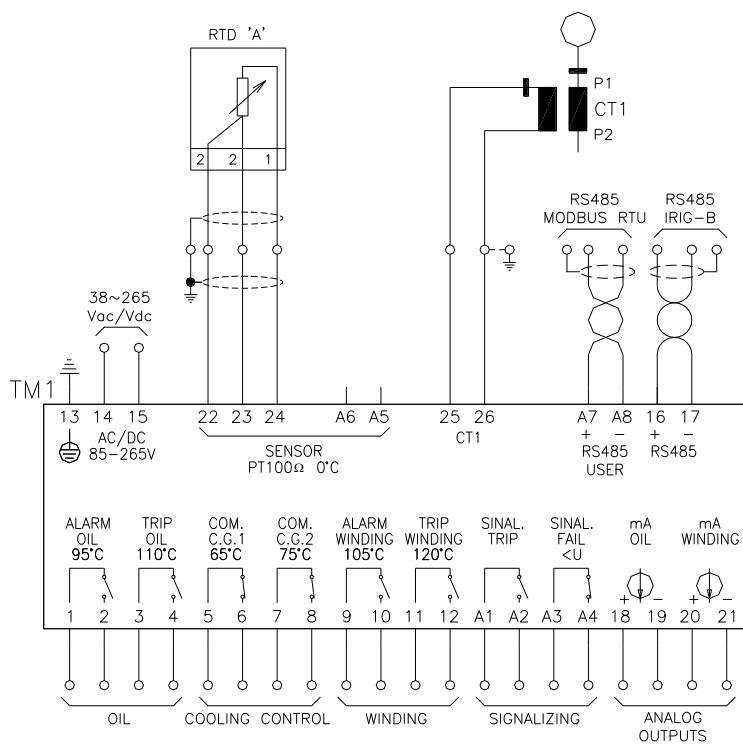

Figure 25 – Connection TM1 / synchronism signal IRIG-B



Whenever only use the input B's PT-100 of TM1 / TM2, check the mandatory connection between points 22 and 23.

4.5 Mechanical Installation

The Temperature Monitors must be installed protected from inclement weather conditions, meaning inside panel boxes or housed in buildings. In any case, there must always be anti-condensation systems.

The Temperature Monitors TM1 and TM2 are suitable for built-in type installations, and can, for instance, be fixed on doors or front plates of panels. Fixation clips are supplied with the devices. The figure below shows the main dimensions of the equipment, as well as the dimensions of the cut out that must be made on the plate to fit it in. Special attention must be given to the thickness of the layers of the paint coat on the plate where the cutout is made, since in some cases, when very thick paint is used, the resulting reduction on the area of the cutout might even make it impossible to install the equipment. Connection terminals are installed in the rear of the TM1 and TM2, 2 removable connectors and in threaded terminals (CT connection for thermal imaging), in order to facilitate the connections. 0.5 to 2.5mm² cables can be used, bare or with “pin” type terminals (or “needle”) for removable connectors, and up to 6mm for the CT connectors with adequate ring-type terminals.

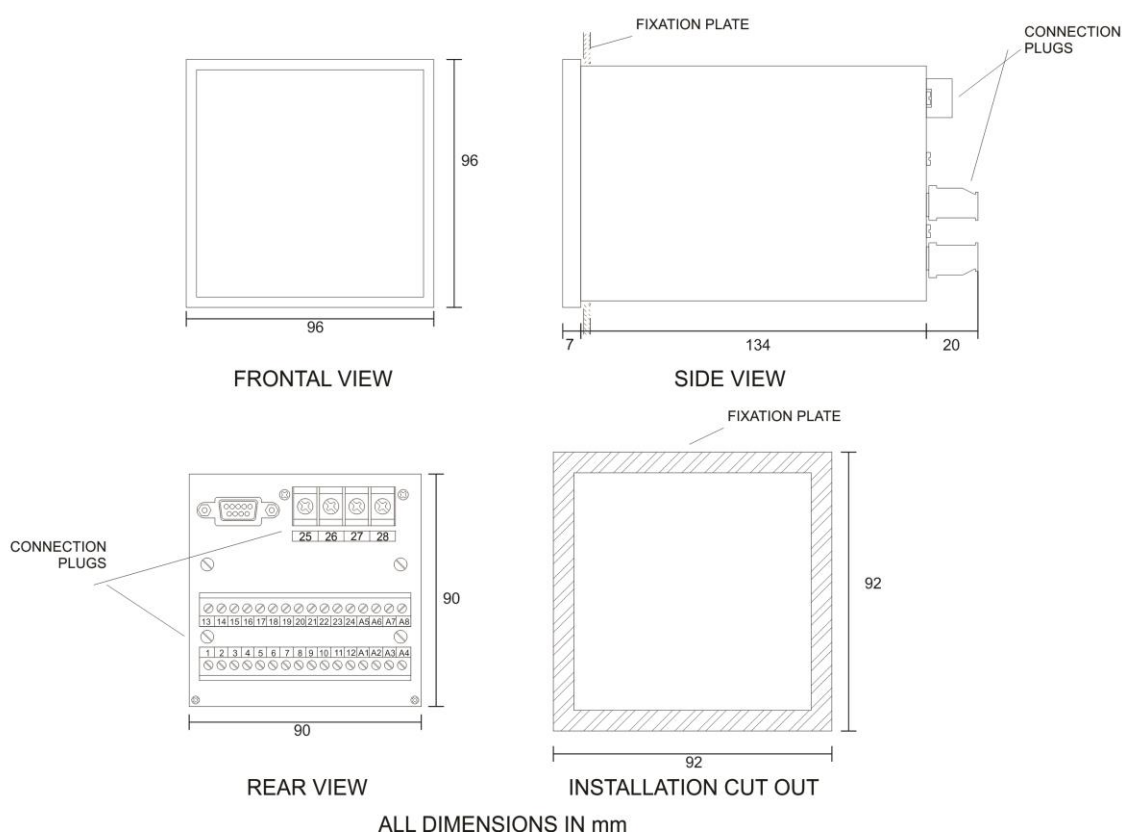

Figure 26 – Dimensions of TM1 and TM2

5 Parameterization

In order to ensure the correct operation of the system, several parameters that will supply the equipment with the information needed for its operation must be adjusted on the TM1 and TM2. These adjustments can be made by way of the front panel keyboard using the display, or through the parameter definition software, by way of the serial communication ports RS232 or RS485, available for the user on the rear panel of the equipment.

The programmable parameters are organized into password protected menus. From the main menu, users will have access to the programming submenus, where they are able to navigate and adjust values in accordance with the transformer's characteristics and user needs.

5.1 Programming

Parameter programming on the Temperature Monitors TM1 and TM2 must be performed during the installation or system commissioning procedures. Adjustments are saved to a non-volatile memory.

When the desired submenu is displayed, press the key  to access it and carry out parameter programming.

5.2 Access to the Programming Menu

To access the programming menu of the Monitors TM1 and TM2, follow the procedure described below:

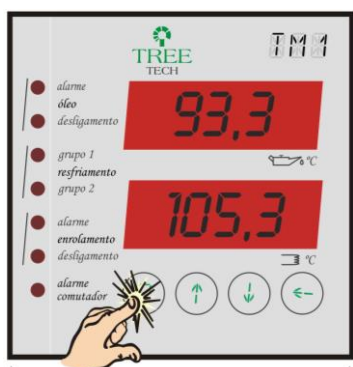

1) On the temperature reading screen, press and hold the **P** key for 5 seconds

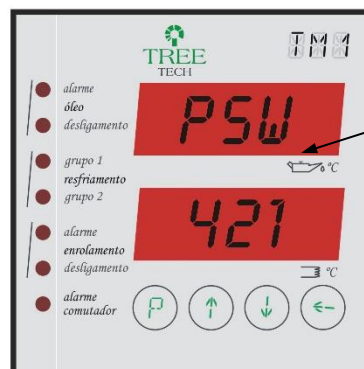

2) The access password screen will come up.

The initial number that is shown when this parameter is reached serves to recover the password. Inform this number to our Technical Assistance Dept. for decoding.

3) Using the **↑** and **↓** keys adjust the password (range = 0 to 999). If initial indication is 421 the password is the factory default, zero. Password can be changed by users

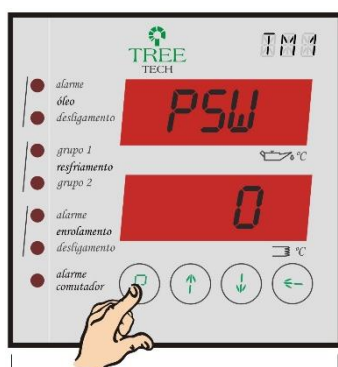

4) After adjusting the password, press and release the **P** key to enter the programming menu.

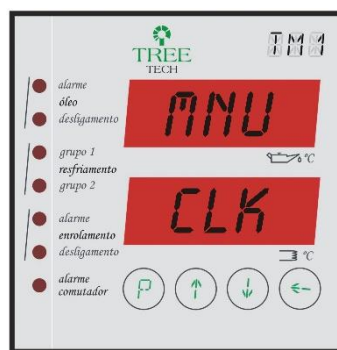

5) Main menu screen, from where it is possible to navigate to the programming submenus.

5.3 Access to submenus

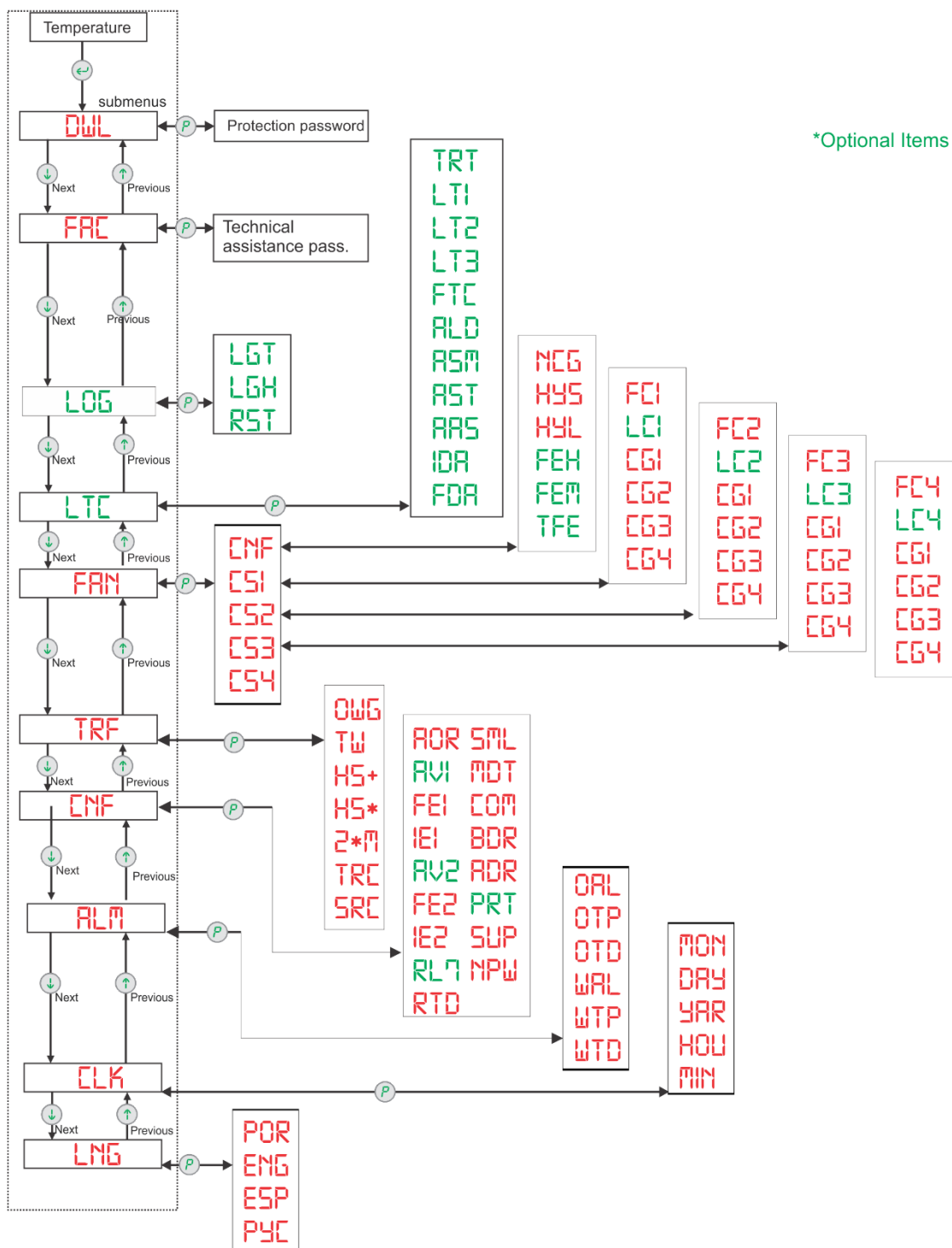

Submenu LNG

Allows the selection of the device's operation language.

With display showing **mnu / LNG**, press  to access the parameters or;



Press  to access **mnu / RLG**, or  to return to measurement indication.



LNG – TM1/TM2 language selection

Set range:

- POR = Portuguese;
- ENG = English;
- ESP = Spanish;
- PYC = Russian.

Press  or  to return to main menu.





Submenu CLK

Permite ajustar o relógio e calendário do aparelho. Este ajuste é efetuado somente no TM1.

Opcionalmente o ajuste do relógio pode ser efetuado pelo protocolo DNP3.0 ou pela entrada IRIG-B, se disponíveis, que realizam o sincronismo do relógio via GPS.

When display shows **mnu / CLK**, press  to access parameters, or;

Press  to access **mnu / ALM**, or  to return to measurement indication.



MON – Month

Set Range: 1 to 12 months, in steps of 1 month.

Press  to acces parameter DAY



DAY – Day

Set Range: 1 to 31 dias, in steps of 1 day.

Press  to access parameter YAR



YAR – Year

Set Range: 3 to 99 (year 2003 to 2099), in steps of 1 year.

Press  to access parameter HOR



HOU – Hour



Set Range: 0 to 23 hours, in 1 hour steps.

Press  to access parameter MIN.



MIN – Minute

Set Range: 0 to 59 minutes, in 1 minute steps.



Press  or  to return to main menu



Submenu ALM

This submenu permits access to all parameters relative to alarms and trips. Extended temperature range from -55 to 200°C for 4-key hardware and from 0 to 150°C for 3-key hardware.

With the display showing **mnu / ALM**, press the  key for access to alarm parameters or;

Press  key to go to the configuration menu **mnu / cfn**, or the  key to return to the menu **mnu / CLK**.



5.3.1.1 TM1 Temperature Monitor – Submenu ALM

OAL – oil temperature alarm

Adjustment range: -55 to 200°C, in 1°C increments

Press  key to advance to parameter OTP



OTP – trip due to oil temperature

Adjustment range : -55 to 200°C, in 1°C increments

Press  key to advance to parameter OTD



OTD – trip due to oil temperature delay

Adjustment range: 0 to 20 min., in 0.1min. increments

Press  key to advance to parameter WAL



WAL – winding 1 temperature alarm

Adjustment range: -55 to 200°C, in 1°C increments

Press  key to advance to parameter WTP



WTP – trip due to temperature in winding 1



Adjustment range: -55 to 200°C, in 1°C increments

Press  key to advance to parameter WTD



WTD – delay for trip due to temperature in winding 1

Adjustment range: 0 to 20 min., in 0.1min. increments

Press  or  key to return to the main menu



5.3.1.2 TM2 Temperature Monitor – Submenu ALM

WAL – winding 2 temperature alarm

Adjustment range: -55 to 200°C, in 1°C increments

Press  key to advance to parameter WTP



WTP – trip due to temperature in winding 2



Adjustment range: -55 to 200°C, in 1°C increments

Press  key to advance to parameter WTD



WTD – delay for trip due to temperature in winding 2

Adjustment range: 0 to 20 min., in 0.1min. increments

Press  or  key to return to the main menu



WAL – winding 3 temperature alarm

Adjustment range: -55 to 200°C, in 1°C increments

Press  key to advance to parameter WTP



WTP – trip due to temperature in winding 3

Adjustment range: -55 to 200°C, in 1°C increments

Press  key to advance to parameter WTD



WTD – delay for trip due to temperature in winding 3

Adjustment range: 0 to 20 min., in 0.1min. increments

Press  or  key to return to the main menu



Submenu CNF

Allows the device's operation parameters to be accessed

With the display showing mnu / CNF, press the  for access to configuration parameters or;

Press the  key to go to the configuration menu mnu / TRF , or to return to the menu mnu / ALM.

In each parameter use the  and  keys to set the desired value.



5.3.1.3 Monitor de Temperatura TM1 – Submenu CNF

AOR – analog output range (mA). Selects the current loop range for remote reading.

Seleciona o padrão do loop de corrente para indicação remota.

Adjustment range: 0 = 0...1 mA

1 = 0...5 mA

2 = 0...10mA

3 = 0...20mA

4 = 4...20mA



Pressionar a tecla  para avançar ao parâmetro Va1

AV1 – analog variable associated to the analog output 1

Selection of the variable associated to the analog output 1. This parameter will only be shown if the optional for LTC temperature differential is available.

Adjustment range:

- 0 – Oil temperature
- 1 – Winding 1 temperature
- 2 – Winding 2 temperature
- 3 – Winding 3 temperature
- 4 – Hottest winding temperature
- 5 – Temperature sensor A (PTA) connected to TM1
- 6 – Temperature sensor B (PTB) connected to TM1
- 7 – Temperature sensor A (PTA) connected to TM2
- 8 – Temperature sensor B (PTB) connected to TM2
- 9 – Instantaneous temperature differential of LTC 1
- 10 – Instantaneous temperature differential of LTC 2
- 11 – Instantaneous temperature differential of LTC 3
- 12 – Highest instantaneous temperature differential among the 3 LTCs
- 13 – Filtered temperature differential of LTC 1
- 14 – Filtered temperature differential of LTC 2
- 15 – Filtered temperature differential of LTC 3
- 16 – Highest filtered temperature differential among the 3 LTCs

Press  to access parameter FE1



FE1 – Value for the variable for current output 1 end of scale

Adjustment range: -55 to 200°C in increments of 1°C.

Press key  to move to parameter IE1



IE1 – Value for the variable for current output 1 beginning of scale

Adjustment range: -55 to 200°C in increments of 1°C.

Press key  to move to parameter AV2.



VA2 – Variável Associada à Saída de Corrente 2

Selection of the variable associated to the analog output 2. This parameter will only be shown if the optional for LTC temperature differential is available. Adjustment range:

Faixa de ajuste:

- 0 – Oil temperature
- 1 – Winding 1 temperature
- 2 – Winding 2 temperature
- 3 – Winding 3 temperature
- 4 – Hottest winding temperature
- 5 – Temperature sensor A (PTA) connected to TM1
- 6 – Temperature sensor B (PTB) connected to TM1
- 7 – Temperature sensor A (PTA) connected to TM2
- 8 – Temperature sensor B (PTB) connected to TM2
- 9 – Instantaneous temperature differential of LTC 1
- 10 – Instantaneous temperature differential of LTC 2
- 11 – Instantaneous temperature differential of LTC 3
- 12 – Highest instantaneous temperature differential among the 3 LTCs
- 13 – Filtered temperature differential of LTC 1
- 14 – Filtered temperature differential of LTC 2
- 15 – Filtered temperature differential of LTC 3
- 16 – Highest filtered temperature differential among the 3 LTCs



Press  key to advance to parameter FE2

FE2 - sets the value for the variable for current output 2 end of scale

Adjustment range: -55 to 200°C in increments of 1°C.

Press key  to move to parameter IE2



IE2 - sets the value for the variable for current output 2 beginning of scale

Adjustment range: -55 to 200°C in increments of 1°C.

Press key  to move to parameter rL7.



RL7 – Signaling function of output relay 7

Selection of the signaling function associated to the output relay 7. This parameter will only be shown if the optional for LTC temperature differential is available; otherwise the relay will assume the default function of instantaneous signaling of trip. **Adjustment range:**

- 0 – Instantaneous signaling of trip – one or more trip contacts actuated or in countdown process for trip.
- 1 – Alarm by instantaneous LTC temperature differential
- 2 – Alarm by filtered LTC temperature differential
- 3 – Alarm by instantaneous or filtered LTC temperature differential.

Press key  to move to parameter RTD.



RTD – Selects the connection option of the temperature sensor

Adjustment range:

2X3 = 2 redundant Pt100 3-wire sensors for oil temperature

1X4 = 1 Pt100 4-wire sensor for oil temperature

X3A = 1 Pt100 3-wire sensor in input A for oil temperature

X3B = 1 Pt100 3-wire sensor in input B for oil temperature

O+A = 2 sensors Pt100 3-wires to measure oil temperature (sensor A) and another temperature, for instance ambient, LTC or other (sensor B)

Press  key to advance to parameter SML



SML – Pt100 input check by way of electronic RTD simulator

Adjustment Range: ON = use electronic simulator of external Pt100 in simulation.
OFF = use real Pt100 sensor for temperature reading.

During normal system operation, this parameter must be selected to “OFF”.
Every time the device is switched off and on again, this parameter defaults to “OFF”

Press  key to advance to parameter MDT



MDT – Maximum permissible difference between 2 Pt100 with 3 wires, when the option 2x3 is used at parameter RTD

Adjustment range: 1 to 6 °C, in steps of 0,1 °C

Press  to access parameter COM.



COM – Selection of Communication Port

Adjustment range: 232 = use serial RS232 (connector DB9)
485 = use serial RS485 (terminals A7 e A8).

The standard protocol used is MODBUS-RTU; optionally, the 1ms DNP-3.0 with time-stamp protocol can be supplied.

Press  to access parameter BDR.



BDR – Baud Rate

Adjustment range: 9.6 = 9,6 kbps
19.2 = 19,2 kbps
38.4 = 38,4 kbps

Press  to access the parameter END



ADR – device address for communication with TM1

Adjustment Range: 1 to 31, in steps of 1.

Press  to access parameter PRT (if the optional DNP3.0 is available) or SUP.



PRT – Communication Protocol (optional)

This parameter will be shown only if the optional function DNP 3.0 is available.

Adjustment range: MDB = MODBUS-RTU

DNP = DNP 3.0 with 1ms time-stamp de

Pressionar  to access parameter SUP



SUP – Supervision Mode

Informes which devices are connected on the temperature monitoring system

Adjustment range:

- 0 = only TM1
- 1 = TM1 + TM2
- 2 = Not used (reserved option)
- 3 = Not used (reserved option)
- 4 = TM1 + MT2
- 5 = TM1 + IRIG-B



Remarks.:



- 1) Using TM1 + MT2 (SUP = 4), the MT2 address must be 1.
- 2) Using the option TM1 + IRIG-B the use of TM2 module is not possible

Press  key to advance to parameter LNG

NPW – Sets new password for access to programming menus

Adjustment range: 0 to 999 in steps of 1.

Default password = 0.

Press  o  to return to main menu.

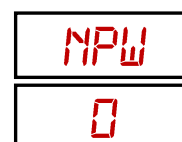

5.3.1.4 Temperature Monitor TM2 – Submenu CNF

AOR – Analog output range (mA)

Selects current loop range for remote reading.

Adjustment range: 0 = 0...1 mA
 1 = 0...5 mA
 2 = 0...10mA
 3 = 0...20mA
 4 = 4...20mA



Press  to access parameter AV1

AV1 – Variable associated do the analog output 1

Selection of the variable associated to the analog output 1. This parameter will only be shown if the optional for LTC temperature differential is available.

Adjustment range.

- 0 – Oil temperature
- 1 – Winding 1 temperature
- 2 – Winding 2 temperature
- 3 – Winding 3 temperature
- 4 – Hottest winding temperature
- 5 – Temperature sensor A (PTA) connected to TM1
- 6 – Temperature sensor B (PTB) connected to TM1
- 7 – Temperature sensor A (PTA) connected to TM2
- 8 – Temperature sensor B (PTB) connected to TM2
- 9 – Instantaneous temperature differential of LTC 1
- 10 – Instantaneous temperature differential of LTC 2
- 11 – Instantaneous temperature differential of LTC 3
- 12 – Highest instantaneous temperature differential among the 3 LTCs
- 13 – Filtered temperature differential of LTC 1
- 14 – Filtered temperature differential of LTC 2
- 15 – Filtered temperature differential of LTC 3
- 16 – Highest filtered temperature differential among the 3 LTCs



Press  to access parameter FE1

FE1 – VALUE for the variable for current output 1 end of scale

Adjustment range: -55 to 200°C in steps of 1°C.

Press  to access parameter IE1



IE1 – Value for the variable for current output 1 end of scale

Adjustment range: -55 to 200°C in steps of 1 °C.

Press  to access parameter AV2.

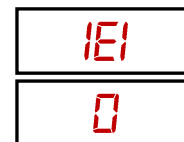

AV2 – Variable associated to the analog output 2

Selection of the variable associated to the analog output 2. This parameter will only be shown if the optional for LTC temperature differential is available.

Adjustment Range:

- 0 0 – Oil temperature
- 1 – Winding 1 temperature
- 2 – Winding 2 temperature
- 3 – Winding 3 temperature
- 4 – Hottest winding temperature
- 5 – Temperature sensor A (PTA) connected to TM1
- 6 – Temperature sensor B (PTB) connected to TM1
- 7 – Temperature sensor A (PTA) connected to TM2
- 8 – Temperature sensor B (PTB) connected to TM2
- 9 – Instantaneous temperature differential of LTC 1
- 10 – Instantaneous temperature differential of LTC 2
- 11 – Instantaneous temperature differential of LTC 3
- 12 – Highest instantaneous temperature differential among the 3 LTCs
- 13 – Filtered temperature differential of LTC 1
- 14 – Filtered temperature differential of LTC 2
- 15 – Filtered temperature differential of LTC 3
- 16 – Highest filtered temperature differential among the 3 LTCs

Press  to access parameter FE2



FE2 – Value for the variable for current output 2 beginning of scale

Adjustment range: -55 to 200°C in steps of 1°C.

Press  to access parameter IE2



IE2 – Value for the variable for current output 2 end of scale

Adjustment range: -55 to 200°C in steps of 1 °C.

Press  to access parameter IE2



RL7 – Signaling function of output relay 7 (optional)

Selection of the signaling function associated to the output relay 7. This parameter will only be shown if the optional for LTC temperature differential is available; otherwise the relay will assume the default function of instantaneous signaling of trip.

Adjustment range:

- 0 - Instantaneous signaling of trip – one or more trip contacts actuated or in countdown process for trip.
- 1 – Alarm by instantaneous LTC temperature differential
- 2 – Alarm by filtered LTC temperature differential
- 3 – Alarm by instantaneous or filtered LTC temperature differential.

Press  to access parameter RTD

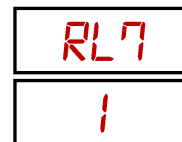

RTD – Selects the connection option of the temperature sensor

Adjustment range:

- OFF = no temperature sensor connected
- 1X4 = 1 Pt100 4-wire sensor
- X3A = 1 Pt100 3-wire sensor in input A
- X3B = 1 Pt100 3-wire sensor in input B
- A+B = 2 sensors Pt100 3-wires

Press  to access parameter SML



SML – Pt100 input check by way of electronic RTD simulator

Adjustment range: ON = use electronic simulator of external Pt100 in simulation.
OFF use real Pt100 sensor for temperature reading.

During normal system operation, this parameter must be selected to “OFF”. Every time the device is switched off and the on again, this parameter defaults to “OFF”.

Press  to advance to parameter ADR



ADR – Device address for communication with TM1

When configuration TM1+TM2 is used, this parameter must be 1.

Adjustment range: 1 to 31

Press  to access parameter DSP



DSP – Indicates variable to be shown at display correspondent to Winding 3, present in TM2.

Adjustment range:

- PTA = Temperature sensor A connected to TM2
- PTB = Temperature sensor B connected to TM2
- WG3 = Winding 3 temperature

OBS: The top display always show the Winding 2 measuring.



Press  to access parameter NPW



NPW – Sets new password for access to programming menus

Adjustment range: 0 to 999 in steps of 1.

Default value = 0.

Press  or  to return to main menu.

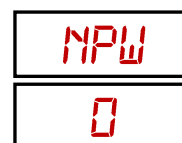

Submenu TRF

Allows access to parameters relative to characteristics of the Transformer / reactor.

With the display showing **mnu / TRF**, press  to access transformer parameters;

Press to go to the configuration menu **mnu / FAN**, or  to return to the **mnu / CNF** menu.



5.3.1.5 Temperature Monitor TM1 – Submenu TRF

OWG – Oil/Winding 1 temperature gradient

This value must be informed by the manufacturer of the transformer / reactor. The figure is obtained by heat run tests or by calculation.

The **OWG** is defined by **IEC 60076-7** as the difference between the average temperature of the winding and the average temperature of the top oil, after thermal stability is achieved under rated load conditions.

At **NBR 5416 / IEEE C57.91-1995** the **OWG** is defined as the elevation of the average temperature of the winding related to the average top oil temperature, after thermal stability is achieved under rated load conditions.

Adjustment range: 0 to 50°C, in steps of 0,1°C.

Press  to access parameter TW.



TW – Time constant for the winding 1. This is the the time constant in seconds, relative.

This is the time constant in seconds, relative to the thermal inertia of the transformer’s winding 1.

This parameter can be measured during the transformer heat run test or calculated by the manufacturer of the transformer. In case it cannot be obtained either way, the typical value of 300 s can be adopted.

Adjustment Range: 72 to 999, in steps 1.

Press  to access parameter HS+.

TW
300

HS+ - Hot-spot factor (ANSI / ABNT)

This is the difference between the hottest-spot and the average temperature of the winding, adopted by standards ABNT NBR 5416 e IEEE C57.91-1995.

If these standards are not being followed, this parameter must be set to 0 (zero).

Adjustment range: 0 to 20°C, in steps of 0,1°C.

Press  to access parameter HS*

HS+
0

HS* - Hot-Spot Factor (IEC – 60076-7)

This is the relation between the hottest-spot and the average temperature of the winding, according to standard IEC 60076-7. If this is not the standard selected, this parameter must be programmed to 1 (one).

Adjustment range: 1 to 1,5 in steps of 0,01. Press  to access parameter 2*M

HS*
1.3

2*M – Winding Exponent

Constant defined by the type of cooling used in the transformer.

Adjustment range: 1,6 natural or forced oil flow (non-directed)
1,8 = to the moment not used in standards
2,0 = directed oil flow

The value of this parameter is two times the winding temperature elevation exponente because of cupper losses.

Press  to access parameter TRC

2*M
1.6

TRC – Rated current for the winding 1 of the transformer whose temperature is being determined

Adjustment range: 0 to 99,8kA in steps of 0,01 kA.

Press  to access parameter SRC



SRC – current in secondary of thermal imaging CT for winding 1, with transformer under rated load conditions

Formula: SRC = TRC / CT ratio

Adjustment range: 0,5 a 10A in steps of 0,01 A.

Press  to access parameter OWG (wind. 2)



5.3.1.6 Monitor de Temperatura TM2 –Submenu TRF

OWG – Oil/Winding 1 temperature gradient

This value must be informed by the manufacturer of the transformer / reactor. The figure is obtained by heat run tests or by calculation.

The **OWG** is defined by **IEC 60076-7** as the difference between the average temperature of the winding and the average temperature of the top oil, after thermal stability is achieved under rated load conditions.

At **NBR 5416 / IEEE C57.91-1995** the **OWG** is defined as the elevation of the average temperature of the winding related to the average top oil temperature, after thermal stability is achieved under rated load conditions.

Adjustment range: 0 to 50°C, in steps of 0,1°C.

Press  to access parameter TW.



TW – Time constant for the winding 1. This is the the time constant in seconds, relative.

This is the time constant in seconds, relative to the thermal inertia of the transformer's winding 1.

This parameter can be measured during the transformer heat run test or calculated by the manufacturer of the transformer. In case it cannot be obtained either way, the typical value of 300 s can be adopted.

Adjustment Range: 72 to 999, in steps 1.

Press  to access parameter HS+.



TRC – Rated current for the winding 1 of the transformer whose temperature is being determined

Adjustment range: 0 to 99,8kA in steps of 0,01 kA.

Press  to access parameter SRC

5
TRC

SRC – current in secondary of thermal imaging CT for winding 1, with transformer under rated load conditions

Formula: $SRC = TRC / CT \text{ ratio}$

Adjustment range: 0,5 to 10A in steps of 0,01 A.

Press  to access parameter OWG (wind. 2)

3.33
SRC

OWG – Oil/Winding 1 temperature gradient

This value must be informed by the manufacturer of the transformer / reactor. The figure is obtained by heat run tests or by calculation.

The **OWG** is defined by **IEC 60076-7** as the difference between the average temperature of the winding and the average temperature of the top oil, after thermal stability is achieved under rated load conditions.

At **NBR 5416 / IEEE C57.91-1995** the **OWG** is defined as the elevation of the average temperature of the winding related to the average top oil temperature, after thermal stability is achieved under rated load conditions.

Adjustment range: 0 to 50°C, in steps of 0,1°C.

Press  to access parameter TW.

OWG
10

TW – Time constant for the winding 1. This is the the time constant in seconds, relative.

This is the time constant in seconds, relative to the thermal inertia of the transformer's winding 1.

This parameter can be measured during the transformer heat run test or calculated by the manufacturer of the transformer. In case it cannot be obtained either way, the typical value of 300 s can be adopted.

Adjustment Range: 72 to 999, in steps 1.

Press  to access parameter HS+.

TW
300

TRC – Rated current for the winding 1 of the transformer whose temperature is being determined

Adjustment range: 0 to 99,8kA in steps of 0,01 kA.

Press  to access parameter SRC

TRC
5

SRC – current in secondary of thermal imaging CT for winding 1, with transformer under rated load conditions

Formula: $SRC = TRC / CT \text{ ratio}$

Adjustment range: 0,5 to 10A in steps de 0,01 A.

Press  to access parameter OWG (wind. 2)



SRC
3.33

Submenu FAN

It allows access to the parameters referring to the configurations of forced cooling operation. These parameters are adjusted in TM1 only. Adjustments are carried out only on TM1. Some special functions for control of the cooling equipment (fans and/or pumps) are optional.

Cooling operation adjustments are subdivided in some additional submenus showed below.

With the display showing mnu / FAN, press  key to obtain access to forced cooling setup or;

Press the  key to go to the menu mnu / DTC (if the optional for temperature differential is available) or mnu / LOG (if the optional for mass memory is available) or press  to return to the menu mnu / TRF

MNU
FAN

5.3.1.7 Submenu CNF

It contains the general configuration parameters of Forced Cooling

NCG – Total number of forced cooling groups

In case only the Temperature Monitor TM1 is used, two output contacts are available for cooling command, then NCG parameter will allow an 1 to 2 adjustment range.

In case TM1 and TM2 are used, four contacts will be available and the parameter will have 1 to 4 adjustment range. In this case, it is possible to use the TM2 cooling command contacts as redundancy for TM1 contacts, simply setting the number of groups NCG to 2.

Press key  to proceed to HYS parameter

NCG
4

HYS – Difference between the start and stop temperature of fans/pumps

HYS parameter (hysteresis) sets a value for temperature reduction below the cooling start temperature to deactivate fans/pumps, thus preventing they are activated and subsequently deactivated with small temperature fluctuations

Faixa de ajuste: 0 a 9 °C; in steps of 1 °C.

Press  to access parameter HYL.

HYS
5

HYL – It is the difference between the load percentage to start and stop fans/pumps

Load hysteresis parameter (HYL) sets a value for load percentage reduction below the cooling start load to deactivate fans/pumps, thus preventing they are activated and subsequently deactivated with small load fluctuations.

This parameter will only be shown in case the Temperature Monitor features the optional Pre-Cooling function.

Adjustment range: 0 to 9%, in steps of 1%

Press  to access parameter FEH

HYL
5

FEH – Start time of Fans/Pumps Exercise

Adjust the time in which the forced cooling groups have to be activated for the daily exercise of fans/pumps.

This parameter will only be shown in case the Temperature Monitor features the optional Cooling Exercise function.

Adjustment Range: 0 to 23, by 1 hour.

Press  to access parameter FEM

FEH
22

FEM – Start minute of Fans/Pumps Exercise

Adjust supplementary time (minute) in which the forced cooling groups have to be activated for the daily exercise of fans or pumps.

This parameter will only be shown in case the Temperature Monitor features the optional Cooling Exercise function.

Adjustment range: 0 to 59 minutes, in steps of 1 minute.

Press  to access parameter TFE

FEM
30

TFE – Time of fans Exercise

Adjust total daily time the forced cooling groups have to remain activated for the exercise of fans or pumps. In case Cooling Exercise function needs to be deactivated, simply set this parameter to zero.

This parameter will only be shown in case the Temperature Monitor features the optional Cooling Exercise function.

Adjustment range: 0 to 999 minutes, in steps of 1 minute.

Press  or  to return to submenu FAN.

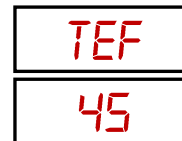

5.3.1.8 Submenus CS1, CS2, CS3, CS4

CS1, CS2, CS3 and CS4 submenus allow to adjust the operation parameters of forced Cooling Stages 1 to 4, respectively. Basically, each submenu has the same parameters, as shown below.

FC1 / FC2 / FC3 / FC4 – Activation temperature of the 1st / 2nd / 3rd / 4th Forced Cooling Stage

When the temperature of one of the transformer windings reaches the set value, one of the Cooling Groups enrolled in the corresponding Cooling Stage (selected as "YES" in CG1, CG2, CG3 and CG4 parameters of each Stage) will be activated.

Adjustment range: -55 to 200°C, in steps of 1°C

Press  to access parameters LC1 / LC2 / LC3 / LC4.

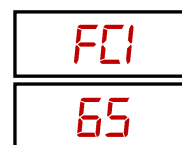

LC1 / LC2 / LC3 / LC4 – Percentage of Load to activate the 1st / 2nd / 3rd / 4th Forced Cooling Stage

When the load percentage of one of the transformer windings reaches the set value, one of the Cooling Groups enrolled in the corresponding Cooling Stage (selected as "YES" in CG1, CG2, CG3 and CG4 parameters of each Stage) will be activated.

Adjustment range: 50 to 200%, in steps 1%

Press  to access parameter CG1.

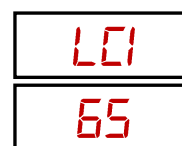

CG1 – Enrollment of Cooling Group 1 in the 1st / 2nd / 3rd / 4th Forced Cooling Stage

It allows to select if Cooling Group 1 will be enrolled in the 1st / 2nd / 3rd / 4th Forced Cooling Stage or not, that is, if it can be considered as available or not to be used by the Cooling Stage when its activation temperature or load percentage is reached.

Adjustment range: YES or NO

Press  to access parameter CG2.

GR2
YES

CG2 – Enrollment of Cooling Group 2 in the 1st / 2nd / 3rd / 4th Forced Cooling Stage

It allows to select if Cooling Group 2 will be enrolled in the 1st / 2nd / 3rd / 4th Forced Cooling Stage or not, that is, if it can be considered as available or not to be used by the Cooling Stage when its activation temperature or load percentage is reached.

Adjustment range: YES or NO

Press  to access parameter CG3.

CG2
YES

CG3 – Enrollment of Cooling Group 3 in the 1st / 2nd / 3rd / 4th Forced Cooling Stage

It allows to select if Cooling Group 3 will be enrolled in the 1st / 2nd / 3rd / 4th Forced Cooling Stage or not, that is, if it can be considered as available or not to be used by the Cooling Stage when its activation temperature or load percentage is reached.

Adjustment range: YES or NO

Press  to access parameter CG4.

GR3
NO

CG4 – Enrollment of Cooling Group 4 in the 1st / 2nd / 3rd / 4th Forced Cooling Stage

It allows to select if Cooling Group 4 will be enrolled in the 1st / 2nd / 3rd / 4th Forced Cooling Stage or not, that is, if it can be considered as available or not to be used by the Cooling Stage when its activation temperature or load percentage is reached.

Adjustment range: YES or NO



Press key  or  to return to FAN submenu.

GR4
NO

Submenu LTC (optional)

It allows access to the parameters referring to the monitoring of Load Tap Changer temperature differential. This submenu will only be shown if this optional monitoring function is available. These parameters are adjusted in TM1 only.

With the display showing mnu / LTC, press  key to obtain access to temperature differential setup or;

Press the  key to go to the menu mnu / LOG (if the optional for mass memory is available) or press  to return to the menu mnu / FAN.

Em cada parâmetro, utilizar as teclas  e  para ajustar o valor desejado.



TRT – Selection of transformer oil temperature sensor used for differential calculation

Adjustment range:

- 1 – Sensor RTD A of TM1
- 2 – Sensor RTD B of TM1
- 3 – Sensor RTD A of TM2
- 4 – Sensor RTD B of TM2
- 5 – Top oil temperature

Press  to access parameter LT1



LT1 - Selection of LTC 1 temperature sensor

Adjustment range:

- 0 – None (temperature differential of LTC 1 not used)
- 1 – Sensor RTD A of TM1
- 2 – Sensor RTD B of TM1
- 3 – Sensor RTD A of TM2
- 4 – Sensor RTD B of TM2

Press  to access parameter LT2



LT2 - Selection of LTC 2 temperature sensor

Adjustment range:

- 0 – None (temperature differential of LTC 1 not used)
- 1 – Sensor RTD A of TM1
- 2 – Sensor RTD B of TM1
- 3 – Sensor RTD A of TM2
- 4 – Sensor RTD B of TM2

Press  to access parameter LT3

LT2

0

LT3 - Selection of LTC 3 temperature sensor

Adjustment range:

- 0 – None (temperature differential of LTC 1 not used)
- 1 – Sensor RTD A of TM1
- 2 – Sensor RTD B of TM1
- 3 – Sensor RTD A of TM2
- 4 – Sensor RTD B of TM2

Press  to access parameter FTC

TC3

0

FTC – Filtering time-constant for the LTC temperature differentials

Adjustment range: 0 to 720 minutes, in steps of 1 minute.

Press  to access parameter ALD

CTF

180

ALD – Alarm time delay for LTC temperature differentials

Adjustment range: 0 to 240 minutes, in steps of 1 minute.

Press  to access parameter ASM

ALD

20

ASM – Temperature margin for automatic alarm settings for LTC temperature differentials

Adjustment range: 1 to 10°C, in steps of 1°C

Press  to access parameter AST

ASM

5.0

AST – Total Time For Automatic Alarm Settings For LTC Temperature Differentials

Adjustment range: 1 to 720 horas, in steps of 1 hour.

Press  to access parameter AAS

AST

336

AAS – Automatic Alarm Settings For LTC Temperature Differentials

It allows starting (ON) or stopping (OFF) the process for automatic alarm settings of instantaneous and filtered LTC temperature differentials.

By selecting ON the time countdown for automatic learning of settings will start with the value programmed in the parameter AST above.

Adjustment range: ON or OFF.

Press  to access IDA



IDA – Instantaneous Differential Alarm For Ltcs (consultation or manual adjustment)

Adjustment range: -40 to +40°C, in steps of 0,1°C

Press  to access parameter FDA



FDA – Alarme por Diferencial de Temperatura Filtrado dos Computadores Sob Carga

Faixa de ajuste: -40 a +40°C, em passos de 0,1°C



Pressionar a tecla  ou  para retornar ao menu principal.



Submenu LOG (optional)

It allows adjustment of the parameters that define the recording of measurements and events in the mass memory. This submenu will only be shown if this optional function is available. These parameters are adjusted in TM1 only. The mass memory is type FIFO (First In First Out), that is, when the end of the memory is reached oldest data are overwritten by newer ones. A new recording in memory can be triggered based on a time interval or a temperature change greater than the adjusted value, as well as by the occurrence of any event (alarm, trip or forced cooling activation).

With the display showing mnu / Log, press  key to obtain access to mass memory setup or;

Press the  key to go to the menu mnu / fab or press  to return to the menu mnu / DTC or fan.



LGT – Time interval to perform a new recording in memory

It establishes the time interval to perform a new recording in the mass memory, in minutes.

Adjustment range: 1 to 120 minutos, in steps of 1 minute.

Press  to access parameter LGH



LGH – Temperature variation to perform a new recording in memory

It establishes the time interval to perform a new recording in the mass memory, in minutes. This resource allows to extend the time so that the oldest data memory to be overwritten, preventing recordings if the measurements do not vary significantly.

Adjustment range: 1 to 20°C, in steps of 1°C.



Press  to access parameter RST



RST – Memory reset command

It allows the restart of the mass memory by erasing all the stored data. User must confirm this option by selecting YES and pressing  key. This process may take several seconds; during this time the display will keep the message RST / YES.

Adjustment range: NO or YES.

Press  or  to return to main menu.



5.4 Typical adjusts

	Standard / Temperature Rise					
	ABNT		ANSI		IEC	
	55 °C	65 °C	55 °C	65 °C	55 °C	65 °C
TW – Time Constant of the winding	300					
2*M – Exponent of the winding	1.6 for natural and forced (non-directed) oil 2.0 for directed oil					
HS+ ANSI / ABNT (°C) hot spot factor	10	15	10	15	0	
HS* IEC hot spot factor	1.0				1.3	
FC1...FC4 – Start up temperature for cooling stages 1 to 4	According to transformer manufacturer instructions					
OAL – Oil temperature alarm	95 °C					
WAL – Winding temperature alarm (°C)	105 °C					
OTP – Oil trip temperature (°C)	110 °C					
WTP – Winding trip temperature (°C)	120 °C					
OTD and WTD – Trip delay (minutes)	2					
HYS – Hysteresis (°C)	4...6					
SUP –Supervision mode	SUP = 0 → TM1 SUP = 1 → TM1 + TM2 SUP = 4 → TM1 + MT2 SUP = 5 → TM1 + IRIG-B					
ADR – Address of TM1 and TM2 in the communication networks.	TM1: ADR = 1 to 31 (device's address on the communication network for data acquisition)					
	TM2 / MT2: ADR = 1 (device's address for communication with TM1)					

6 Start-up procedure for putting equipment in operation

Once the equipment has been installed, putting the equipment in operation must follow the basic steps described below

- Make sure that no operation of contacts will interfere or interact with other systems, during this phase. Remove the lower connectors (terminals 1...A4) of TM1 and TM2, this way insulating all the command, alarm and trip contacts.
- Check electrical installation. Check suitability of electrical wiring (for example, through continuity testing).
- Make sure that no current transformer (CT) secondary will be open during installation and operation of the temperature monitors. Short-circuit and ground CT secondaries that will be connected to the temperature monitors before undertaking any operation if the transformer is energized during installation of TM1 and TM2. After installation is completed, carry out detailed and careful check of this wiring before removing the short-circuit from the secondaries.
- If dielectric rigidity tests are carried out on the wiring (applied voltage), disconnect grounding cables connected to terminals 13 of TM1 and TM2 in order to prevent destruction of over-voltage protection equipment found in the device. These protections are connected internally between input/output terminals and ground, stapling voltage at about 300V. Application of high voltages for long periods of time (for example, 2kV for 1 minute) would destroy this protection.
- Reconnect ground cable to terminals 13 of TM1 and TM2, if it was disconnected for the applied voltage test. Energize TM1 and TM2 with any voltage in the 38 to 265Vdc/Vac 50/60Hz range.
- Perform all the necessary parameter definitions for the TM1 and TM2. The parameter settings performed can be written down in the form of the next page.
- Connect a temperature calibrator, resistive decade or check the temperature of Pt100 sensors connected to TM1 to check the measurements.
- Inject ac current in the CT inputs of TM1 and TM2 or measure the current of the bushing CT circuit and check it on the TM's consultation screens.
- Using dc milliamp meter, check current loop outputs with the corresponding temperatures measured.
- With a continuity detection device, test action of alarm, trip and forced cooling contacts. Contacts can be activated by reducing alarm set values to lower values than those for current readings.
- Reconnect the lower connector (1...A4) of TM1 and TM2 if they were removed for start-up.

Temperature Monitor TM1 – Parameter Settings					
Serial No.:		Date:		Responsible:	
Submenu	Parameter	Description		Value Set	
ALM	OAL	Oil alarm temperature		°C	
	OTP	Oil trip temperature		°C	
	OTD	Oil trip delay		min	
	WAL	Winding 1 alarm temperature		°C	
	WTP	Winding 1 trip temperature		°C	
	WTD	Winding 1 trip delay		min	
CNF	AOR	Analog output range			
	AV1 (op.)	Variable associated to Analog Output 1			
	FE1	Analog output 1 end-of-scale		°C	
	IE1	Analog output 1 beginning-of-scale		°C	
	AV2 (op.)	Variable associated to Analog Output 2			
	FE2	Analog output 2 end-of-scale		°C	
	IE2	Analog output 2 beginning-of-scale		°C	
	RL7 (op.)	Signaling function of Output Relay 7			
	RTD	Connection option for temperature sensors			
	SML	Pt100 input check by way of electronic RTD simulator			
	MDT	Maximum temp. difference (option RTD 2x3)			
	COM	Serial communication port used			
	BDR	Serial communication baud-rate		bps	
	ADR	Serial communication address			
	PRT (op.)	Communication protocol			
SUP	Supervision mode				
NPW	New menu access password				
TRF / ALL	OWG	Oil-winding 1 temperature gradient		°C	
	TW	Winding 1 time-constant		sec.	
	HS+	Hot-spot factor by ANSI and ABNT standards		°C	
	HS*	Hot-spot factor by IEC standard			
	2*M	Exponent defined by type of cooling			
	TRC	Rated current of winding 1		kA	
	SRC	Winding 1 CT secondary current at rated load		A	

TRF / CS0	OWG	Oil-winding 1 temperature gradient	°C
	TW	Winding 1 time-constant	sec.
	HS+	Hot-spot factor by ANSI and ABNT standards	°C
	HS*	Hot-spot factor by IEC standard	
	2*M	Exponent defined by type of cooling	
	TRC	Rated current of winding 1	kA
	SRC	Winding 1 CT secondary current at rated load	A
TRF / CS1	OWG	Oil-winding 1 temperature gradient	°C
	TW	Winding 1 time-constant	sec.
	HS+	Hot-spot factor by ANSI and ABNT standards	°C
	HS*	Hot-spot factor by IEC standard	
	2*M	Exponent defined by type of cooling	
	TRC	Rated current of winding 1	kA
	SRC	Winding 1 CT secondary current at rated load	A
TRF / CS2	OWG	Oil-winding 1 temperature gradient	°C
	TW	Winding 1 time-constant	sec.
	HS+	Hot-spot factor by ANSI and ABNT standards	°C
	HS*	Hot-spot factor by IEC standard	
	2*M	Exponent defined by type of cooling	
	TRC	Rated current of winding 1	kA
	SRC	Winding 1 CT secondary current at rated load	A
TRF / CS3	OWG	Oil-winding 1 temperature gradient	°C
	TW	Winding 1 time-constant	sec.
	HS+	Hot-spot factor by ANSI and ABNT standards	°C
	HS*	Hot-spot factor by IEC standard	
	2*M	Exponent defined by type of cooling	
	TRC	Rated current of winding 1	kA
	SRC	Winding 1 CT secondary current at rated load	A
TRF / CS4	OWG	Oil-winding 1 temperature gradient	°C
	TW	Winding 1 time-constant	sec.
	HS+	Hot-spot factor by ANSI and ABNT standards	°C
	HS*	Hot-spot factor by IEC standard	
	2*M	Exponent defined by type of cooling	
	TRC	Rated current of winding 1	kA
	SRC	Winding 1 CT secondary current at rated	A

		load	
FAN / CNF	NCG	Total number of cooling groups	
	HYS	Hysteresis for turning off cooling groups	°C
	HYL (op.)	Load hysteresis for turning off cooling groups	%
	FEH (op.)	Set hour to turn on cooling groups	hour
	FEM (op.)	Set minute to turn on cooling groups	min.
	TFE (op.)	Total cooling operation time	min.
Subme nu	Paramet er	Description	Value Set
FAN / CS1	FC1	Operation temperature of cooling stage 1	°C
	SCT	Stage Control Temperature	Oil/Wid
	LC1 (op.)	Percent load for turning on cooling stage 1	%
	CG1	Registration of Cooling Group 1 for Stage 1	
	CG2	Registration of Cooling Group 2 for Stage 1	
	CG3	Registration of Cooling Group 3 for Stage 1	
	CG4	Registration of Cooling Group 4 for Stage 1	
FAN / CS2	FC2	Operation temperature of cooling stage 2	°C
	SCT	Stage Control Temperature	Oil/Wid
	LC2 (op.)	Percent load for turning on cooling stage 2	%
	CG1	Registration of Cooling Group 1 for Stage 2	
	CG2	Registration of Cooling Group 2 for Stage 2	
	CG3	Registration of Cooling Group 3 for Stage 2	
	CG4	Registration of Cooling Group 4 for Stage 2	
FAN / CS3	FC3	Operation temperature of cooling stage 3	°C
	SCT	Stage Control Temperature	Oil/Wid
	LC3 (op.)	Percent load for turning on cooling stage 3	%
	CG1	Registration of Cooling Group 1 for Stage 3	
	CG2	Registration of Cooling Group 2 for Stage 3	
	CG3	Registration of Cooling Group 3 for Stage 3	
	CG4	Registration of Cooling Group 4 for Stage 3	
FAN / CS4	FC4	Operation temperature of cooling stage 4	°C
	SCT	Stage Control Temperature	Oil/Wid
	LC4 (op.)	Percent load for turning on cooling stage 4	%
	CG1	Registration of Cooling Group 1 for Stage 4	
	CG2	Registration of Cooling Group 2 for Stage 4	
	CG3	Registration of Cooling Group 3 for Stage 4	
	CG4	Registration of Cooling Group 4 for Stage 4	
LTC (op.)	TRT	Selection of transformer temperature sensor	
	LT1	Selection of LTC 1 temperature sensor	

	LT2	Selection of LTC 2 temperature sensor	
	LT3	Selection of LTC 3 temperature sensor	
	FTC	Filter time-constant for temperature differential	min.
	ALD	Alarm delay for LTC temperature differential	min.
	ASM	Margin for automatic differential alarm settings	°C
	AST	Learning time for automatic alarm settings	hours
	AAS	Automatic Alarm Settings For LTC	
	IDA	Instantaneous LTC differential alarm	°C
	FDA	Filtered LTC differential alarm	°C
LOG (op.)	LGT	Time interval for mass memory recording	min.
	LGH	Temperature variation for memory recording	°C
	RST	Memory reset command	
Temperature Monitor TM2 – Parameter Settings			
Serial No.:		Date:	Responsible:
Submenu	Parameter	Description	Value Set
ALM	WAL (2)	Winding 2 alarm temperature	°C
	WTP (2)	Winding 2 trip temperature	°C
	WTD (2)	Winding 2 trip delay	min
	WAL (3)	Winding 3 alarm temperature	°C
	WTP (3)	Winding 3 trip temperature	°C
	WTD (3)	Winding 3 trip delay	min
CNF	AOR	Analog output range	
	AV1 (op.)	Variable associated to Analog Output 1	
	FE1	Analog output 1 end-of-scale	°C
	IE1	Analog output 1 beginning-of-scale	°C
	AV2 (op.)	Variable associated to Analog Output 2	
	FE2	Analog output 2 end-of-scale	°C
	IE2	Analog output 2 beginning-of-scale	°C
	RL7 (op.)	Signaling function of Output Relay 7	
	ADR	Address for communication with TM1	
	RTD	Connection option for temperature sensors	
	NPW	New menu access password	
TRF	OWG (2)	Oil-winding 2 temperature gradient	°C
	TW (2)	Winding 2 time-constant	sec.

	TRC (2)	Rated current of winding 2	kA
	SRC (2)	Winding 2 CT secondary current at rated load	A
	OWG (3)	Oil-winding 3 temperature gradient	°C
	TW (3)	Winding 3 time-constant	sec.
	TRC (3)	Rated current of winding 3	kA
	SRC (3)	Winding 3 CT secondary current at rated load	A





7 Troubleshooting

The Temperature Monitor's software constantly checks the integrity of its functions and of the sensors and modules connected to it. Any abnormality is checked, and when verified it is signaled through its failure contact. Messages will be displayed on the TMs, helping in the failure diagnosis process.

In case problems are found or difficulties faced in operating the system, we suggest consulting the possible simple causes and solutions presented below. If this information is not sufficient to solve the difficulty, please contact Treetech's technical assistance service or any of its authorized representatives.

7.1 The device displays self-diagnosis messages on the display

The self-diagnostic function implemented in the Temperature Monitors TM1 and TM2 allows detection and diagnosis of any eventual external defects or even internal failures of the equipment, in most cases allowing users to identify and correct problems quickly.

To access the internal error memory of TM1/TM2, press and hold for a few seconds the  e  keys. All errors that have been occurred will be shown in superposition, and to clean this memory, press and hold for a while the segundos  e  keys.

When a problem is detected, the TM1 or TM2 will show the abbreviation "ERR" on the upper display, while the lower one will show the code for the failure that is occurring. The meaning for the different codes is shown in the tables below, respected the digit of the display in which the code appears.

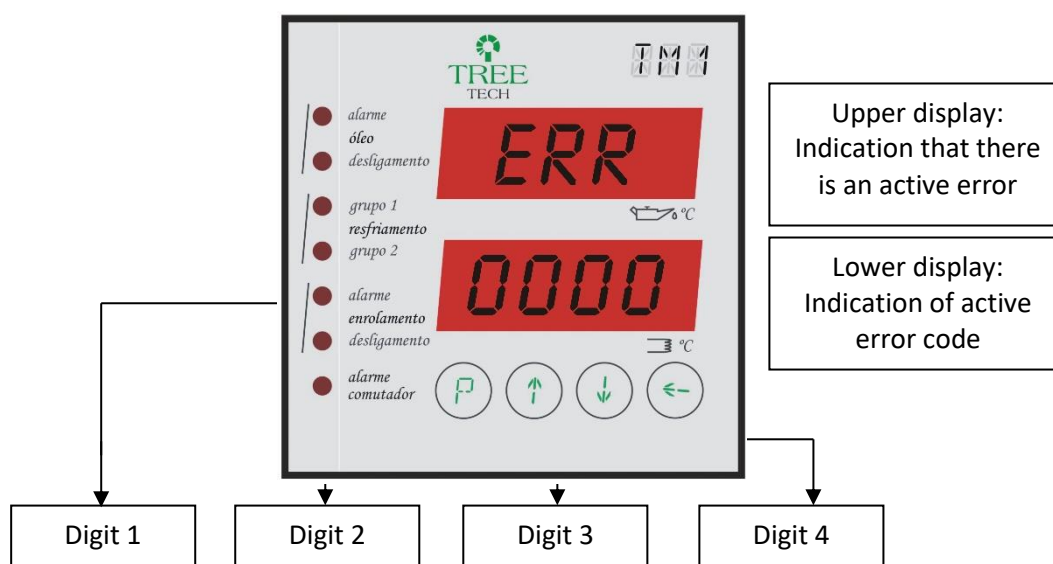

Figure 27 – Self-diagnostic indications

Table 5 – Digit 1 failures







Digit 1			
Code displayed	Description	Probable causes	Actions recommended
0	No failure in this digit.	-	-
1	Failure in measuring temperature of sensor A – sudden change, in excess of 5°C, between consecutive temperature measurements	Bad contact or disconnection in one of the cables connected to terminals 1 and/or 2 of the temperature sensor A.	Check for bad contact or disconnection along the entire length of the cables connected to terminals 1 and 2 of the temperature sensor A, including the connection to TM, to passage terminals and to the sensor.
		Use of unshielded cable in connection between sensor Pt100 and TM.	Make sure that shielded cable is being used to connect Pt100 sensor A to the temperature monitor.
		Cables connecting Pt 100 sensor to TM not grounded or grounded in more than one point.	Make sure shielding of connection cable between TM and temperature sensor A is grounded only on one side of the connection and that the other end is insulated, as per figure 4.3, page II-6.
		Internal failure in temperature sensor A.	Replace defective temperature sensor A.
		<u>After checking and correcting cause of failure in reading, reset the error by pressing and holding the keys  and .</u> ATTENTION: in resetting, the TM is informed that the current value of the temperature reading is correct. If the device is reset with an incorrect temperature reading, this may trigger incorrect alarm, for instance due to LTC temperature differential.	
2	Failure in measuring temperature of sensor B – sudden change, in excess of 5°C, between consecutive temperature measurements	Bad contact or disconnection in one of the cables connected to terminals 1 and/or 2 of the temperature sensor B.	Check for bad contact or disconnection along the entire length of the cables connected to terminals 1 and 2 of the temperature sensor B, including the connection to TM, to passage terminals and to the sensor.
		Use of unshielded cable in connection between sensor Pt100 and TM.	Make sure that shielded cable is being used to connect Pt100 sensor B to the temperature monitor.
		Cables connecting Pt 100 sensor to TM not grounded or grounded in more than one point.	Make sure shielding of connection cable between TM and temperature sensor B is grounded only on one side of the connection and that the other end is insulated, as per figure 4.3, page II-6.
		Internal failure in temperature sensor B.	Replace defective temperature sensor B.
		<u>After checking and correcting cause of failure in reading, reset the error by pressing and holding the keys  and .</u> ATTENTION: in resetting, the TM is informed that the current value of the temperature reading is correct. If the device is reset with an incorrect temperature reading, this may trigger incorrect alarm, for instance due to LTC temperature differential.	
3	Simultaneous occurrence of codes 1 and 2 above	see codes 1 and 2 above.	Proceed as indicated for codes 1 and 2 above

Table 6 – Digit 2 Failures

		Digit 2	
Code displayed	Description	Probable causes	Actions recommended
0	<i>No failure in this digit.</i>	-	-
1	<i>Failure in measuring temperature sensor <u>A</u>.</i>	<i>Sensor A is not in use, but its reading is enabled in parameter RTD.</i>	<i>Disable reading of sensor not used by changing the parameter RTD.</i>
		<i>Bad contact on cable connected to terminal 1 of the temperature sensor A.</i>	<i>Check for bad contact along the entire length of the cable connected to terminal 1 of the temperature sensor A, including the connection to TM, to passage terminals and to the sensor.</i>
		<i>Internal failure in temperature sensor A.</i>	<i>Replace defective temperature sensor A.</i>
2	<i>Failure in measuring temperature sensor <u>B</u>.</i>	<i>Sensor B is not in use, but its reading is enabled in parameter RTD.</i>	<i>Disable reading of sensor not used by changing the parameter RTD.</i>
		<i>Bad contact on cable connected to terminal 1 of the temperature sensor B.</i>	<i>Check for bad contact along the entire length of the cable connected to terminal 1 of the temperature sensor B, including the connection to TM, to passage terminals and to the sensor.</i>
		<i>Internal failure in temperature sensor B.</i>	<i>Replace defective temperature sensor B.</i>
3	<i>Simultaneous occurrence of codes 1 and 2 above</i>	<i>see codes 1 and 2 above.</i>	<i>Proceed as indicated for codes 1 and 2 above</i>
4	<i>Failure in measuring temperature sensor <u>A</u>.</i>	<i>Sensor A is not in use, but its reading is enabled in parameter RTD.</i>	<i>Disable reading of sensor not used by changing the parameter RTD.</i>
		<i>Bad contact on cable connected to terminal 2 of the temperature sensor A.</i>	<i>Check for bad contact along the entire length of the cable connected to terminal 2 of the temperature sensor A, including the connection to TM, to passage terminals and to the sensor.</i>
		<i>Internal failure in temperature sensor A.</i>	<i>Replace defective temperature sensor A.</i>
5	<i>Simultaneous occurrence of codes 1 and 4 above</i>	<i>see codes 1 and 4 above.</i>	<i>Proceed as indicated for codes 1 and 4 above</i>
6	<i>Simultaneous occurrence of codes 2 and 4 above</i>	<i>see codes 2 and 4 above.</i>	<i>Proceed as indicated for codes 2 and 4 above</i>

7	Simultaneous occurrence of codes 1, 2 and 4 above	see codes 1, 2 and 4 above.	Proceed as indicated for codes 1, 2 and 4 above
8	Failure in measuring temperature sensor B.	Sensor B is not in use, but its reading is enabled in parameter RTD.	Disable reading of sensor not used by changing the parameter RTD.
		Bad contact on cable connected to terminal 2 of the temperature sensor B.	Check for bad contact along the entire length of the cable connected to terminal 2 of the temperature sensor B, including the connection to TM, to passage terminals and to the sensor.
		Internal failure in temperature sensor B.	Replace defective temperature sensor B.
9	Simultaneous occurrence of codes 1 and 8 above	see codes 1 and 8 above.	Proceed as indicated for codes 1 and 8 above
A	Simultaneous occurrence of codes 2 and 8 above	see codes 2 and 8 above.	Proceed as indicated for codes 2 and 8 above
B	Simultaneous occurrence of codes 1, 2 and 8 above	see codes 1, 2 and 8 above.	Proceed as indicated for codes 1, 2 and 8 above
C	Simultaneous occurrence of codes 4 and 8 above	see codes 4 and 8 above.	Proceed as indicated for codes 4 and 8 above
D	Simultaneous occurrence of codes 1, 4 and 8 above	see codes 1, 4 and 8 above.	Proceed as indicated for codes 1, 4 and 8 above
E	Simultaneous occurrence of codes 2, 4 and 8 above	see codes 2, 4 and 8 above.	Proceed as indicated for codes 2, 4 and 8 above
F	Simultaneous occurrence of codes 1, 2, 4 and 8 above	see codes 1, 2, 4 and 8 above.	Proceed as indicated for codes 1, 2, 4 and 8 above

Table 7 – Digit 3 Failures

0000		Digit 3	
Code displayed	Description	Probable causes	Actions recommended
0	No failure in this digit.	-	-
1	Failure in measuring temperature – sudden change, in excess of 5°C, between consecutive temperature measurements or high temperature difference between sensors A and B.	The parameter RTD is programmed with option 2X3 in TM1, but only one sensor is being used for top oil temperature measurement.	Revise programming of parameter RTD, according to the configuration being used temperature sensors.
		Parameter MDT (Maximum Difference of Temperature between top oil redundant sensors A and B) programmed too low in TM1.	Revise programming of parameter RTD, so as to avoid it to be lower than the normal temperature difference between top oil temperature sensors A e B.
		Bad contact or disconnection in one of the cables connected to terminals 1 and/or 2 of the temperature sensors A and/or B.	Check for bad contact or disconnection along the entire length of the cables connected to terminals 1 and 2 of the temperature sensors A and B, including the connection to TM, to passage terminals and to the sensors.
		Use of unshielded cable in connection between sensors Pt100 and TM.	Make sure that shielded cable is being used to connect Pt100 sensors to the temperature monitor.
		Cables connecting Pt 100 sensors to TM not grounded or grounded in more than one point.	Make sure shielding of connection cables between TM and sensors Pt100 are grounded only on one side of the connection and that the other end is insulated.
		Internal failure in temperature sensors A and/or B.	Replace defective temperature sensor A and/or B.
		<u>After checking and correcting cause of failure in reading, reset the error by pressing and holding the keys  and  of TM1 for about 2 seconds. ATTENTION: in resetting, the TM1 is informed that the current value of the temperature reading is correct. If the device is reset with an incorrect, high temperature reading, this may trigger incorrect alarm or transformer trip events.</u>	
2	Internal Error – AD Converter	Internal failure of TM.	Replace defective TM and contact Treetech Technical Assistance.
3	Simultaneous occurrence of codes 1 and 2 above	see codes 1 and 2 above.	Proceed as indicated for codes 1 and 2 above
4	Failure in measuring load current	Internal failure of TM.	Replace defective TM and contact Treetech Technical Assistance.

5	Simultaneous occurrence of codes 1 and 4 above	see codes 1 and 4 above.	Proceed as indicated for codes 1 and 4 above
6	Simultaneous occurrence of codes 2 and 4 above	see codes 2 and 4 above.	Proceed as indicated for codes 2 and 4 above
7	Simultaneous occurrence of codes 1, 2 and 4 above	see codes 1, 2 and 4 above.	Proceed as indicated for codes 1, 2 and 4 above
8	Failure in measuring load current	Internal failure of TM.	Replace defective TM and contact Treetech Technical Assistance.
9	Simultaneous occurrence of codes 1 and 8 above	see codes 1 and 8 above.	Proceed as indicated for codes 1 and 8 above
A	Simultaneous occurrence of codes 2 and 8 above	see codes 2 and 8 above.	Proceed as indicated for codes 2 and 8 above
B	Simultaneous occurrence of codes 1, 2 and 8 above	see codes 1, 2 and 8 above.	Proceed as indicated for codes 1, 2 and 8 above
C	Simultaneous occurrence of codes 4 and 8 above	see codes 4 and 8 above.	Proceed as indicated for codes 4 and 8 above
D	Simultaneous occurrence of codes 1, 4 and 8 above	see codes 1, 4 and 8 above.	Proceed as indicated for codes 1, 4 and 8 above
E	Simultaneous occurrence of codes 2, 4 and 8 above	see codes 2, 4 and 8 above.	Proceed as indicated for codes 2, 4 and 8 above
F	Simultaneous occurrence of codes 1, 2, 4 and 8 above	see codes 1, 2, 4 and 8 above.	Proceed as indicated for codes 1, 2, 4 and 8 above

Table 8 – Digit 4 failures

0000		Digit 4	
Code displayed	Description	Probable causes	Actions recommended
0	No failure in this digit.	-	-
1	Communication error between TM1 and TM2.	Bad contact or inversion on cables connected to terminals 16 and/or 17 of TM1 and/or TM2.	Check for bad contact, disconnections or inversions along the entire length of the cable connected to terminal 16 and/or 17 of TM1 and/or TM2 Temperature Monitors, including connection to monitors and passage terminals.
		Use of non-shielded cable in linking TM1 and TM2 Temperature Monitors.	Check for use of shielded cable in linking TM1 and TM2 Temperature Monitors.
		Cable shielding on cable linking TM1 to TM2 not grounded or grounded in more than one point.	Check shielding on cable linking TM1 to TM2 is grounded only at one end of the connection with the other end insulated.
		Incorrect programming for parameter SUP.	Correct programming for parameter SUP.
		Incompatibility between firmware versions in deploying a TM with the old MT line.	TM1 or TM2 Temperature Monitors can only be connected to the monitors of line MT with firmware version V2.2 or higher.
2	Incorrect programming for parameter SUP	One of the options not used (options 2 or 3) was programmed for parameter SUP.	Correct programming for parameter SUP, using one of the valid options (0, 1, 4 or 5), according to whether TM1 is used alone or together with TM2.
3	Simultaneous occurrence of codes 1 and 2 above	see codes 1 and 2 above.	Proceed as indicated for codes 1 and 2 above
4	Internal error – EEPROM Memory	Internal failure of TM.	Replace defective TM and contact Treetech Technical Assistance.
5	Simultaneous occurrence of codes 1 and 4 above	see codes 1 and 4 above.	Proceed as indicated for codes 1 and 4 above
6	Simultaneous occurrence of codes 2 and 4 above	see codes 2 and 4 above.	Proceed as indicated for codes 2 and 4 above
7	Simultaneous occurrence of codes 1, 2	see codes 1, 2 and 4 above.	Proceed as indicated for codes 1, 2 and 4 above

	<i>and 4 above</i>		
8	<i>Measurement Overflow</i>	<i>Internal failure of TM.</i>	<i>Replace defective TM and contact Treetech Technical Assistance.</i>
9	<i>Simultaneous occurrence of codes 1 and 8 above</i>	<i>see codes 1 and 8 above.</i>	<i>Proceed as indicated for codes 1 and 8 above</i>
A	<i>Simultaneous occurrence of codes 2 and 8 above</i>	<i>see codes 2 and 8 above.</i>	<i>Proceed as indicated for codes 2 and 8 above</i>
B	<i>Simultaneous occurrence of codes 1, 2 and 8 above</i>	<i>see codes 1, 2 and 8 above.</i>	<i>Proceed as indicated for codes 1, 2 and 8 above</i>
C	<i>Simultaneous occurrence of codes 4 and 8 above</i>	<i>see codes 4 and 8 above.</i>	<i>Proceed as indicated for codes 4 and 8 above</i>
D	<i>Simultaneous occurrence of codes 1, 4 and 8 above</i>	<i>see codes 1, 4 and 8 above.</i>	<i>Proceed as indicated for codes 1, 4 and 8 above</i>
E	<i>Simultaneous occurrence of codes 2, 4 and 8 above</i>	<i>see codes 2, 4 and 8 above.</i>	<i>Proceed as indicated for codes 2, 4 and 8 above</i>
F	<i>Simultaneous occurrence of codes 1, 2, 4 and 8 above</i>	<i>see codes 1, 2, 4 and 8 above.</i>	<i>Proceed as indicated for codes 1, 2, 4 and 8 above</i>

7.2 TM1/TM2 reads incorrect values for temperatures

Table 9 – Incorrect reading of values for temperatures

<i>Probable causes</i>	<i>Actions recommended</i>
<i>Incorrect programming of quantity and configuration of temperature sensors in parameter RTD.</i>	<i>Check for correct programming of the parameter RTD on submenu CNF.</i>
<i>Bad-contact or disconnection in one of the cables connected to terminals 1 and/or 2 of the temperature sensors.</i>	<i>Check for bad contact points or disconnections along the entire length of cables connected to terminals 1 and/or 2 of the temperature sensor, including connection to TM, passage terminals and to temperature sensors.</i>
<i>Use of non-shielded cables in connection between Pt100 sensors</i>	<i>Check whether shielded cables are being used in connecting temperature sensors to TM.</i>

<i>and TM.</i>	
<i>Shielding for cables connecting TM to sensors Pt100 is not grounded or grounded in more than one place.</i>	<i>Check that cable shielding on cables linking TM to temperature sensors are grounded in just one end of the connection and the other end insulated.</i>
<i>Failure of temperature sensor.</i>	<i>Replace defective temperature sensor.</i>

7.3 TM1/TM2 reads incorrectly values for load currents

Table 10 – Incorrectly values for load currents

<i>Probable causes</i>	<i>Actions recommended</i>
<i>CT (Current Transformer) Secondary short-circuited</i>	<i>Check whether the secondary of the CT is short-circuited. Check that secondary of CT is properly connected to the temperature monitor before removing short-circuit, thus avoiding the secondary of the Ct from running open.</i>
<i>Power of CT exceeded.</i>	<i>Check if load created by wiring of CT secondary causes maximum power to be exceeded, causing error in readings (input impedance fort TM can be ignored). Increase cable gauge to reduce load.</i>
<i>Incorrectly programmed rated current for transformer winding for parameter TRC.</i>	<i>Correct programming for parameter TRC for each winding monitored.</i>

7.4 TM1/TM2 indicates incorrect values for winding temperatures

Table 11 – Incorrect values for winding temperatures

<i>Probable causes</i>	<i>Actions recommended</i>
<i>Error in measuring CT secondary current for CT connected to the Temperature Monitors.</i>	<i>Proceed as in item 7.3 above.</i>
<i>Not all inputs for AC current measurement are used.</i>	<i>It is normal that, for unused current inputs, the temperature for the corresponding winding shown is the same as for temperature of the oil.</i>
<i>Incorrect programming of one or more of the following parameters: OWG, TW, HS+, HS*, 2*M e SRC.</i>	<i>Check and correct programming for these parameters for each winding.</i>

7.5 TM1 does not communicate with the data acquisition system

Table 12 – No communication between TM1 and Data Acquisition system

<i>Probable causes</i>	<i>Actions recommended</i>
<i>Incorrect programming of serial communication parameters on TM1.</i>	<i>Check for correct programming of the following parameters on submenu CNF:</i> <ul style="list-style-type: none"> - <i>Communication port COM</i> - <i>Baud-rate – parameter BDR</i> - <i>Address – parameter ADR</i>

	- Protocol – parameter PRT
<i>Bad-contact, disconnection or inversion in one of the serial communication cables.</i>	<i>Check for bad contact points, disconnections or inversions along the entire length of communication cables, including connection to TM1, passage terminals and to data acquisition system.</i>
<i>Unshielded cable, shielding without grounding or incorrectly grounded used in connection between data acquisition system and the TM1.</i>	<i>Use shielded cable.</i>
<i>Incorrect type of cable used</i>	<i>Communication cable must be shielded twisted pair type.</i>
<i>Distance between ends of communication network superior to 1300 meters</i>	<i>If total circuit length exceeds distance of 1300 meters, repeater modules or fiber optic cables must be used.</i>

7.6 Remote reading through analog output incorrect

Table 13 – Remote reading through analog output incorrect

<i>Probable causes</i>	<i>Actions recommended</i>
<i>Incorrect programming of current output parameters</i>	<i>Check programming of the following parameters on menu CNF:</i> <ul style="list-style-type: none"> - Analog Output Range – AOR - Variable for Analog Output 1 – AV1 - End of scale of output 1 – FE1 - Beginning of scale of output 1 – IE1 - Variable for Analog Output 2 – AV2 - End of scale of output 2 – FE2 - Beginning of scale of output 2 – IE2
<i>Incorrect connection of connection cable</i>	<i>Check proper connection of cables (polarity, eventual short circuits, open links or grounding) between TM1 and TM2 and measuring system.</i>
<i>Maximum load exceeded</i>	<i>Check maximum load for each output standard selected.</i>
<i>Lack of grounding, grounding interrupted or cable shield grounded at both ends of the circuit.</i>	<i>Grounding failure may allow noise and induced transients to make current loop readings impossible. Proceed with cable and connections check (passage terminals) and grounding.</i>

7.7 TM1/TM2 does not correctly activate the forced cooling

Table 14 - Incorrect activate the forced cooling

<i>Probable Causes</i>	<i>Possible Solutions</i>
<i>Incorrect setting of forced cooling control parameters.</i>	<i>Correct the settings of forced cooling control parameters.</i>

8 Attachments

8.1 Attachment A

Technical Data

Supply Voltage:	38 to 265 Vac/Vdc 50/60Hz
Maximum Consumption:	< 8 W
Operating Temperature:	-40 to +85 °C
Protection Degree:	IP 20
Wire size, except CT inputs:	22 to 12 AWG, 0.3 to 2.5mm ²
Wire size - CT inputs:	one or two 16 to 12 AWG, 1.5 to 2.5mm ² using appropriate ring-type terminal lugs
Mounting:	Built in panel
Analog outputs:	2 (w/ common positive) for each device (TM1 or TM2)
Maximum error:	0.5 % of full scale
options (selections) and maximum load:	0...1 mA, 10kΩ 0...5 mA, 2kΩ 0...10 mA, 1kΩ 0...20 mA, 500Ω 4...20 mA, 500Ω
Relay outputs:	Potential free contacts
Type and functions (standard):	5NO (alarms/trip)+3NC (2 C.G.+1 self-diagnosis) for each device (TM1 or TM2)
Maximum switching power:	70 W (dc) / 250 VA (ac) non-inductive
Maximum switching voltage:	250Vdc / 250 Vac
Maximum conduction current:	5 A
Direct temperature measurements (for instance, oil, ambient, LTC):	Inputs for RTD sensors w/ continuous self-calibration
Sensor:	Pt100Ω@ 0°C
Measuring range:	-55...200°C
Maximum error @ 20°C:	0.4% of full scale
Deviation by temperature variation:	20ppm/°C
Connection options for each device (TM1 or TM2):	two 3-wire sensors one 4-wire sensor or one 3-wire sensor
Winding temperature measurement	Calculated
Mathematical models applied:	IEEE C57.91-1995 EC 354 - 1991 ABNT NBR 5416-1997 (Brazilian standard)
AC measurement input:	Direct CT measurement or external clip-on CT
Working range:	0...10 A
Maximum error @ 20°C:	0.5% of end of scale (1% with clip-on CT)
Deviation by temperature variation:	50ppm/°C
Communication protocols (access through TM1):	Modbus RTU (standard) or DNP3.0 level 1 (optional)
Serial Communication Ports:	1 RS 485, interconnection TM1/TM2 or IRIG-B

Mass Memory (optional):	1 user selectable RS 485/RS 232, supervision system (at TM1 only)
Recording interval:	1 to 120 minutes
Temperature variation for recording:	1 to 20°C
Capacity:	
TM1 without LTC Temperature Differential:	1465 registers
TM1 with LTC Temperature Differential:	948 registers
TM1+TM2 without LTC Temperature Diff.:	848 registers
TM1+TM2 with LTC Temperature Diff.:	645 registers

8.2 Attachment B

Order Specification

The Temperature Monitors TM1 and TM2 are universal item equipment, with its features being selected by using the programming menus. These adjustments can be made directly on the device's front panel or by way of the serial communication ports RS232 or RS485. The power feed input is universal (38 to 265 Vdc/Vac 50/60Hz).

Therefore, in purchase orders for the equipment only the following need to be informed:

- Temperature Monitor TM1 (oil and one winding temperature):
 - Quantity;
 - Desired optional functions:
 - Optional 1 – Communication protocol DNP3.0 level 1 (in addition to Modbus RTU protocol)
 - Optional 2 – Pre-cooling
 - Optional 3 – Cooling groups Exercising
 - Optional 4 – LTC Temperature Differential
 - Optional 5 – Mass Memory
 - Type of CT connection: standard model for direct CT connection (0-10A) or optional model for external clip-on CT (clip-on CTs not included, must be ordered separately as optional accessories).
 - Physical configuration of each relay individually (NO or NC), in case this is different from the standard.
- Temperature Monitor TM2 (two additional winding temperatures):
 - Quantity;
 - Type of CT connection: standard model for direct CT connection (0-10A) or optional model for external clip-on CT (clip-on CTs not included, must be ordered separately as optional accessories).

- Physical configuration of each relay individually (NO or NC), in case this is different from the standard.

Attention: The Temperature Monitor TM2 must operate obligatorily with Temperature Monitor TM1, and cannot be operated alone.

8.3 Attachment C

Type testing

Surge Immunity (IEC 60255-22-5):	
phase-neutral surges:	1 kV, 5 per polarity (+/-)
phase-ground and neutral-ground surges:	2 kV, 5 per polarity (+/-)
Electrical transients Immunity (IEC 60255-22-1 and IEEE C37.90.1):	
1st cycle peak	2.5 kV
frequency:	1.1 MHz
time and repetition rate:	2 seconds, 400 surges/sec.
decay to 50%:	5 cycles
Voltage Impulse (IEC 60255-5):	
Wave form:	1,2 / 50 microseconds
Amplitude and energy:	5kV, 0.5J
Number of pulses:	3 negative e 3 positive, 5s interval
Insulation Voltage (IEC 60255-5):	
Industrial frequency insulation voltage	2 kV 60Hz 1 min. to ground
Irradiated electromagnetic field Immunity (IEC 61000-4-3 / IEC60255-22-3):	
Frequency:	26 to 1000 MHz
Field intensity:	10 V/m
Conduced electromagnetic perturbations immunity IEC 60255-22-6):	
Frequency:	0.15 to 80 MHz
Field intensity:	10 V/m
Electrostatic Discharge (IEC 60255-22-2 and IEEE C37.90.3):	
Air mode:	8 kV, ten discharges per polarity
Contact mode:	6 kV, ten discharges per polarity
Fast electrical transient immunity (IEC60255-22-4 and C37.90.1):	
Power supply, inputs and outputs:	4 kV
Serial communication port:	2 kV
Climatic test: (IEC 60068-2-14):	
Temperature range:	-40 to +85°C
Total test time:	96 hours
Vibration response: (IEC 60255-21-1):	
Application mode:	3 axis (X, Y e Z), sinusoidal

	Amplitude:	0,075mm from 10 to 58 Hz 1G from 58 to 150 Hz
	Duration:	8 min/axis
Vibration resistance: (IEC 60255-21-1):	Application mode:	3 axis (X, Y e Z), sinusoidal
	Frequency	10 to 150 Hz
	Amplitude:	2G
	Duration:	160 min/axis
Short duration overload (IEEE C57.109-1993 and NBR 8145/83):		AC current measurement inputs

8.4 Attachment D

Compatibility between versions

This is an informative about the compatibility between the available versions of the Treetech Temperature Monitor, complying with the device's three generations: MT, Three Keys TM an Four Keys TM.

Frequent questions:

1. **Is it possible applying TM1 and TM2 with diferente versions?**

Yes, but with a few restrictions. According to the table below. Neveththeless, it is always recommended to use equipments with the same firmware version, as they are updated and tested together by Treetechs' Team.

2. **Is it possible applying MT1 with TM2?**

Yes, observing the compatibility described in table below.

3. **Is it possible applying TM1 with MT2?**

Yes, observing the compatibility described in table below.

Table 15 – Compatibility between firmwares

<i>Equipamento</i>			<i>Compatível com:</i>		
<i>Type</i>	<i>Model</i>	<i>Last version</i>	<i>Typo</i>	<i>Model</i>	<i>Version</i>
MT1	All	2.3	MT2	All	2.3
			TM2	3 Keys	2.02 a 3.14
			TM2	4 Keys	3.05 a 3.10
MT2	All	2.3	MT1	All	2.3

			TM1	3 Keys	2.02 a 3.14
			TM1	4 Keys	3.05 a 3.10
TM1	3 Keys	3.14	MT2	All	2.3
			TM2	3 Keys	2.02 a 3.14
			TM2	4 Keys	3.05 a 3.10
TM2	3 Keys	3.14	MT1	All	2.3
			TM1	3 Keys	2.02 a 3.14
			TM1	4 Keys	3.05 a 3.10
TM1	4 Keys	4.14	TM2	4 Keys	3.05 a 4.14
		4.16			
			TM2	4 Keys	4.15 a 4.16
TM2	4 Keys	4.16	TM1	4 Keys	4.00 a 4.16

Notes:

The above table has established compatibilities in devices without any optionals.

The 3 Keys TM1 monitors, which versions are 3.05 or higher operate with 4 Keys TM2 version 4.14 or lower in compatibility. There is an operational restriction for analog output of TM2.

Conclusion:

Starting with version 4.15, the TM1 monitors are not compatible with previous versions than 4.15. The reason are the updates and new functions incorporated to TM1/TM2 monitors.

If there are any doubts about this attachment, please, contact Treetech's Technical Assistance.



Treetech

BRAZIL

Treetech Sistemas Digitais Ltda
Praça Claudino Alves, 141, Centro
CEP 12.940-000 - Atibaia/SP
+ 55 11 2410-1190
comercial@treetech.com.br
www.treetech.com.br