

USER MANUAL



Treetech

MBR

Membrane/Bladder Rupture Relay



Contents

1	FOREWORD	1
1.1	LEGAL INFORMATION	1
1.1.1	<i>Disclaimer</i>	1
1.2	PRESENTATION	1
1.3	TYPOGRAPHICAL CONVENTIONS	1
1.4	GENERAL AND SAFETY INFORMATION	1
1.4.1	<i>Safety symbols</i>	1
1.4.2	<i>General symbology</i>	2
1.4.3	<i>Recommended minimum profile for the MBR operator and maintainer</i>	2
1.4.4	<i>Environmental and voltage conditions required for installation and operation</i>	3
1.4.5	<i>Instructions for testing and installation</i>	4
1.4.6	<i>Instructions for cleaning and decontamination</i>	4
1.4.7	<i>Instructions for inspection and maintenance</i>	4
1.5	CUSTOMER SERVICE	7
1.6	WARRANTY TERM	8
2	INTRODUCTION	9
2.1	MAIN FEATURES	10
2.1.1	<i>Inputs</i>	11
2.1.2	<i>Outputs</i>	11
2.1.3	<i>Communication</i>	11
2.2	BASIC OPERATING PHILOSOPHY	12
2.2.1	<i>RTC (Real Time Clock)</i>	12
2.3	LOGS	12
2.3.1	<i>Mass Memory Log</i>	12
2.4	INTENDED USE	12
3	DESIGN AND INSTALLATION	13
3.1	SYSTEM TOPOLOGY	13
3.2	ELECTRICAL INSTALLATION	13
3.3	CABLE SPECIFICATION	14
3.4	CONNECTION DIAGRAM	15
3.4.1	<i>Input and output terminals</i>	16
3.4.2	<i>Power and Grounding</i>	16
3.4.3	<i>Communication ports</i>	16
3.4.3.1	RS-485 Communication	16
3.4.4	<i>MBR sensor</i>	17
3.4.5	<i>Self-diagnosis relay</i>	17
3.4.6	<i>Membrane rupture alarm relays</i>	17
3.5	MECHANICAL INSTALLATION	18
3.5.1	<i>Pre-installation of CP-MBR</i>	19
3.5.1.1	Use of the Bypass Collar directly on the pipe that reaches the expansion tank	19
3.5.1.2	Connected directly to the expansion tank access point	22
3.5.1.3	Connected to a "T" shaped access on the pipe leading to the expansion tank	23
3.5.1.4	Connected to expansion tank access point with threaded adapter	23
3.5.1.5	Hole in the expansion tank	23
3.5.1.6	Manufacturing of specific part for installation	23
3.5.2	<i>CP-MBR Installation</i>	24
4	OPERATION	27
4.1	BUTTON FUNCTION	27
4.2	STATUS LED	28
5	PARAMETERIZATION	29



5.1	KEY FUNCTION	29
5.2	RS-485 SERIAL COMMUNICATION.....	29
5.2.1	<i>Communication with Modbus or DNP3 protocol</i>	29
5.3	USER CONTROL ACCESS	30
5.4	SYSTEM AND CONTROL.....	30
5.5	GENERAL.....	31
5.5.1	<i>Maintenance and Cleaning</i>	31
5.5.2	<i>Advanced</i>	32
5.6	UART	32
6	COMMISSIONING FOR ENTRY INTO SERVICE	34
7	TROUBLESHOOTING	35
7.1	VIEWING SELF-DIAGNOSIS MEMORY AND ALARM MEMORY	35
8	TECHNICAL DATA.....	36
9	ORDERING SPECIFICATION.....	37



Illustrations

FIGURE 1 – MBR FRONT	9
FIGURE 2 – COMPOSITION OF THE MEMBRANE/BLADDER RUPTURE DETECTION SYSTEM	13
FIGURE 3 - MBR INPUT AND OUTPUT TERMINALS.....	15
FIGURE 4 - CE CERTIFICATION LABEL	15
FIGURE 5 - EQUIPMENT DIMENSIONS – MBR.....	18
FIGURE 6 – MBR SENSOR DIMENSIONS	19
FIGURE 7 – MEMBRANE/BLADDER RUPTURE RELAY AND MBR SENSOR	19
FIGURE 8 – DUCT.....	20
FIGURE 9 – TUBE DRILLING	20
FIGURE 10 - CABLE ROUTING	21
FIGURA 11 - SEALING.....	21
FIGURE 12 – BYPASS COLLAR	21
FIGURE 13 - HEAD	22
FIGURE 14 – TRANSFORMER.....	22
FIGURE 15 – EXPANSION TANK ACCESS POINT	22
FIGURE 16 – “T” SHAPED ACCESS.....	23
FIGURE 17 – 3/4” BSP ADAPTER.....	23
FIGURE 18 - DRILL.....	23
FIGURE 19 – “T” SHAPED ACCESS.....	23
FIGURE 20 – CP-MBR DIMENSIONS.....	24
FIGURE 21 – LOCATION OF ACCESS POINT IN EXPANSION TANK	24
FIGURE 22 – POSITIONING OF THE MBR PROBE IN THE CONSERVATOR	25
FIGURE 23 – CP-MBR BASE.....	25
FIGURE 24 – INTERIOR OF CP-MBR.....	25
FIGURE 25 – CONNECTION DIAGRAM	26
FIGURE 26 – CONNECTING CABLES TO SPRING-LOADED TERMINALS.....	26
FIGURE 27 – “DEFAULT ADDRESS” BUTTON.....	27



Tables

TABLE 1 - OPERATING CONDITIONS.....	3
TABLE 2 - SPECIFICATION TABLE	13
TABLE 3 - MBR INPUT TERMINALS	16
TABLE 4 - MBR OUTPUT TERMINALS.....	16
TABLE 5 - FRONT LED COLOR CODE	28
TABLE 6 - TECHNICAL DATA.....	36



1 Foreword

1.1 Legal information

The information contained in this document is subject to change without notice.

This document belongs to Treetech Tecnologia Ltda. and cannot be copied, transferred to third parties or used without express authorization, in accordance with Brazilian law 9.610/98.

1.1.1 Disclaimer

Treetech Tecnologia reserves the right to make changes without prior notice to all products, circuits and features described herein in order to improve their reliability, function or design. Treetech Tecnologia assumes no liability resulting from the application or use of any product or circuit described herein, nor does it transfer any licenses or patents under its rights, nor the rights of third parties.

Treetech Tecnologia may hold patents or other types of registrations and intellectual property rights described in the content of this document. Possession of this document by any person or entity does not grant that person or entity any rights to these patents or registrations.

1.2 Presentation

This manual presents all the recommendations and instructions for installation, operation and maintenance of the Membrane/Bladder Rupture Relay – MBR.

1.3 Typographical conventions

Throughout this text, the following typographical conventions have been adopted:

Bold: Symbols, terms and words that are in bold have greater contextual importance. Therefore, pay attention to these terms.

Italics: Terms in a foreign language, alternative terms or terms used outside of the formal context are placed in italics.

Underlined: References to external documents.

1.4 General and safety information

This section will present relevant aspects about safety, installation and maintenance of the MBR.

1.4.1 Safety symbols

This manual uses three types of risk classification as shown below:

**Warning:**

This symbol is used to alert the user to a potentially hazardous operating or maintenance procedure that requires extreme caution when performing it. Minor or moderate injury may occur, as well as damage to the equipment.

**Caution:**

This symbol is used to alert the user to a potentially hazardous operating or maintenance procedure where extreme caution must be exercised. Serious injury or death could result. Possible damage to the equipment will be irreparable.

**Risk of electric shock:**

This symbol is used to alert the user to an operating or maintenance procedure that, if not strictly followed, could result in electric shock. Minor, moderate, or serious injury or death may occur.

1.4.2 General symbology

This manual uses the following general-purpose symbols:

**Important**

This symbol is used to highlight information.

**Tips**

This symbol represents instructions that facilitate the use or access of functions in the MBR.

**Electronic waste**

This symbol represents instructions on the correct disposal of the product at the end of its useful life.

1.4.3 Recommended minimum profile for the MBR operator and maintainer

The installation, maintenance and operation of equipment in electrical power substations require special care and, therefore, all recommendations in this manual, applicable standards, safety procedures, safe work practices and good judgment must be used during all stages of handling the Membrane/Bladder Rupture Relay - MBR.



Only authorized and trained personnel, operators and maintainers should handle this equipment.

To handle the MBR, the professional must:

1. Be trained and authorized to operate, ground, connect and disconnect the MBR, following maintenance procedures in accordance with established safety practices, which are the sole responsibility of the MBR operator and maintainer;
2. Be trained in the use of PPEs, CPEs and first-aid;
3. Be trained in the operating principles of the MBR, as well as its configuration;
4. Follow the normative recommendations regarding interventions in any type of equipment inserted in an electrical power system.

1.4.4 Environmental and voltage conditions required for installation and operation

The following table lists important information about environmental and voltage requirements.

Table 1 - Operating conditions

Condition	Range/description
Application	Equipment for sheltered use in substations, industrial environments and similar.
Indoor/outdoor use	Indoor use
Degree of protection (IEC 60529)	IP20
Altitude (IEC EN 61010-1)	Up to 2000 m



1.4.5 Instructions for testing and installation

This manual must be available to those responsible for the installation, maintenance and users of the Membrane/Bladder Rupture Relay – MBR.

To ensure user safety, equipment protection and correct operation, the following minimum precautions must be followed during the installation and maintenance of the MBR.

1. Read this manual carefully before installing, operating and maintaining the MBR. Errors in the installation, maintenance or adjustment of the MBR may cause undue alarms, failure to issue relevant alarms and thus cause misunderstanding of the actual health and operation status of the transformer.
2. The installation, adjustments and operation of the MBR must be carried out by trained personnel familiar with power transformers with mineral or vegetable oil insulation, control devices and control circuits of substation equipment;
3. Special attention must be given to the installation of the MBR, including the type and gauge of the cables, installation location and commissioning, including the correct parameterization of the equipment.



The MBR must be installed in a sheltered environment (a panel without doors in a control room or a closed panel, in cases of outdoor installation), which does not exceed the temperature and humidity specified for the equipment.



Do not install the MBR near heat sources such as heating resistors, incandescent lamps and high-power devices or devices with heat sinks. It is also not recommended to install it near ventilation holes or where it may be hit by forced air flow, such as the outlet or inlet of cooling fans or forced ventilation ducts.

1.4.6 Instructions for cleaning and decontamination

Be careful when cleaning the MBR. Use **only** a damp cloth with soap or detergent diluted in water to clean the case, front mask or any other part of the equipment. Do not use abrasive materials, polishes, or aggressive chemical solvents (such as alcohol or acetone) on any of its surfaces.



Turn off and unplug the equipment before cleaning any parts of it.

1.4.7 Instructions for inspection and maintenance

For inspection and maintenance of the MBR, the following observations must be followed:



Do not open your equipment. There are no user-serviceable parts inside. This should be done by Treetech technical support, or technicians accredited by Treetech.

This equipment is completely maintenance-free, and visual and operational inspections, whether periodic or not, can be performed by the user. These inspections are not mandatory.



All parts of this equipment must be supplied by Treetech, or by one of its accredited suppliers, according to their specifications. If the user wishes to purchase them in another way, they must strictly follow Treetech specifications for this. In this way, the performance and safety for the user and the equipment will not be compromised. If these specifications are not followed, the user and the equipment may be exposed to unforeseen risks.



Opening the MBR at any time will result in the loss of the product warranty. In cases of improper opening, Treetech will also not be able to guarantee its correct operation, regardless of whether the warranty period has expired or not.

1.4.8 Disposal and end-of-life instructions for the product

This product is subject to the European Directive 2012/19/EU on Waste Electrical and Electronic Equipment (WEEE). To ensure responsible disposal in accordance with the law, please follow the guidelines below:



Upon reaching the end of its useful life, this equipment **should not be disposed of with regular household waste.**



Proper disposal:

- Dispose of the product at a collection point specializing in electronic waste or authorized recycling centers;
- Consult local authorities, distributors, or the manufacturer for information on the nearest collection points;
- Proper disposal helps protect the environment, allows for the recycling of materials, and reduces risks to human health caused by harmful substances present in electronic equipment.

1.4.9 EC Declaration of Conformity (ECD)

This equipment complies with the essential requirements of the following applicable European directives:

- Directive 2014/30/EU (Electromagnetic Compatibility – EMC);
- Directive 2014/35/EU (Low Voltage – LVD);
- Directive 2011/65/EU and 2015/863/EU (RoHS).

The product meets the relevant harmonized standards and complies with the technical requirements established by the European Union. For more details, please refer to the [MBR Declaration of Conformity](#) document.

Authorized Representative in the European Union | EUAR:

TRC SERVICES, LDA.

Rua Manuel Vieira da Cruz, 25, 1º Esq. Trás,

4445-271 Ermesinde | Portugal

+351 220 996 067

www.trcompliance.com | info@trcompliance.com



1.5 Customer service

Are you already familiar with our online customer service platform?

[CS](#)



The CS page provides a quick and direct communication channel with our support team. Ask questions, solve problems and keep your Treotech product application up to date.

The Treotech knowledge base is also available, including catalogs, manuals, application notes, frequently asked questions and more.



In some cases, it will be necessary to send the equipment to Treotech Technical Support. At CS we present the entire procedure and necessary contacts.



The firmware version related to this manual is v1.01 R2.



1.6 Warranty term

The Membrane/Bladder Rupture Relay - MBR will be guaranteed by Treotech for a period of 2 (two) years, counted from the date of purchase, exclusively against any manufacturing defects or quality defects that make it unsuitable for regular use.

The warranty will not cover damage suffered by the product as a result of accidents, mistreatment, incorrect handling, incorrect installation and application, inadequate testing or in the event of breaking the warranty seal.

Any need for technical assistance must be communicated to Treotech or its authorized representative, with presentation of the equipment accompanied by the respective proof of purchase.

No express or implied warranty, other than those stated above, is provided by Treotech. Treotech does not provide any warranty of suitability of the MBR for a particular application.

Seller shall not be liable for any damage to property or any loss or damage arising out of, in connection with, or resulting from the purchase of the equipment, its performance or any service possibly provided in conjunction with the MBR.

In no event shall the seller be liable for any damages whatsoever, including, but not limited to: loss of profits or revenue, inability to use the MBR or any associated equipment, costs of capital, costs of purchased energy, costs of substitute equipment, facilities or services, downtime costs, claims by Buyer's customers or employees, regardless of whether such damages, claims or losses are based on contract, warranty, negligence, tort or otherwise. In no event shall Seller be liable for any personal injury of any kind whatsoever.



2 Introduction



Figure 1 – MBR Front

The Membrane/Bladder Rupture Relay – MBR is a device capable of detecting the rupture of the membrane or rubber bladder used in oil preservation systems in power transformers and reactors.

The MBR consists of an optical sensor, a junction box (optional) and a control unit. The control unit has two relays, one with NC contact and the other with a configurable contact in the initial logic NO or NC, selectable by the user, and an LED for signaling the status and communication of the MBR device.

The MBR works based on the principle of light reflection. When there is no oil present, the light emitted by the LED-emitter is completely reflected by the capsule dome and captured by the optical receiver. If, in the event of a leak, the oil covers the capsule, part of the emitted light is scattered in the oil and the amount of light reaching the optical receiver is reduced, causing the coupling circuits to become unbalanced and the signaling contact to operate.



2.1 Main Features

IED (Intelligent Electronic Device)

This IED has a modern and compact design, being specifically designed for applications in transformers in substations and industrial or commercial installations.

ALARMS AND SELF-DIAGNOSIS

Alarm emission in case of abnormalities and self-diagnosis for detection of internal failures and integration with other sensors.

COMMUNICATION PROTOCOL

Two RS-485 serial communication ports for integration into supervisory or remote monitoring systems. Open Modbus® RTU or DNP3 communication protocols.

MASS MEMORY (default)

Non-volatile memory for storing measurements and alarm events, shutdowns and others. User-defined programming of the interval between recordings.

RGB LED

The Membrane/Bladder Rupture Relay (MBR) includes a user-available LED, which plays an important role in signaling status.

RESET BUTTON FOR SERIAL COMMUNICATION PARAMETERS

The Membrane/Bladder Rupture Relay (MBR) includes a user-available button that allows you to reset the serial communication parameters to factory default values, in case they are forgotten.

RELAYS FOR REMOTE INFORMATION

The product has two relays for indicating alarm and self-diagnosis information.



2.1.1 Inputs

- ✓ 1 input for MBR sensor;

2.1.2 Outputs

- ✓ 2 relays for alarm and self-diagnosis indication;

2.1.3 Communication

- ✓ 2 RS-485 serial communication ports.



2.2 Basic Operating Philosophy

The Membrane/Bladder Rupture Relay – MBR is a system for detecting leaks in the membrane or rubber bladder of the expansion tank of power transformers, reactors and other similar equipment. This system is based on a sensor that is installed on the membrane or inside the rubber bladder of the expansion tank. This sensor is interconnected to a control module installed inside the transformer/reactor control panel, emitting alarms in the event of a rupture of the membrane or bladder.

The operating principle of the Membrane/Bladder Rupture Relay – MBR is based on the principle of light reflection. When there is no oil present, the light emitted by the LED-emitter is completely reflected by the capsule dome and captured by the optical receiver. If, in the event of a leak, the oil covers the capsule, part of the emitted light is scattered in the oil and the amount of light reaching the optical receiver is reduced, causing the coupling circuits to become unbalanced and the signaling contact to operate.

2.2.1 RTC (Real Time Clock)

The RTC is a circuit that enables the equipment to have clock functionality and maintain it in the event of a power failure.

2.3 Logs

Allows you to save the equipment's registered information. If you wish to download it, simply contact Treetech's Customer Service (CS).

2.3.1 Mass Memory Log

It is a non-volatile memory of the equipment. Recordings in this memory are triggered by specific events, such as occurrences of self-diagnosis and alarms, equipment reset, in addition to periodic recording for a time assigned by the user. Data pages are recorded whenever a certain event occurs and can be downloaded through the Treetech Facility software.

2.4 Intended use

The intended use of the Membrane/Bladder Rupture Relay – MBR is to detect rupture of the membrane or rubber bladder used in oil preservation systems in power transformers and reactors. It is essential that the MBR user be aware of the color of the LED located on the front of the equipment. The LED plays an important role in signaling communication problems and alerts, providing visual information about the status of the system.



3 Design and Installation

3.1 System Topology

Basically, the Membrane/Bladder Rupture Relay - MBR system is composed of:

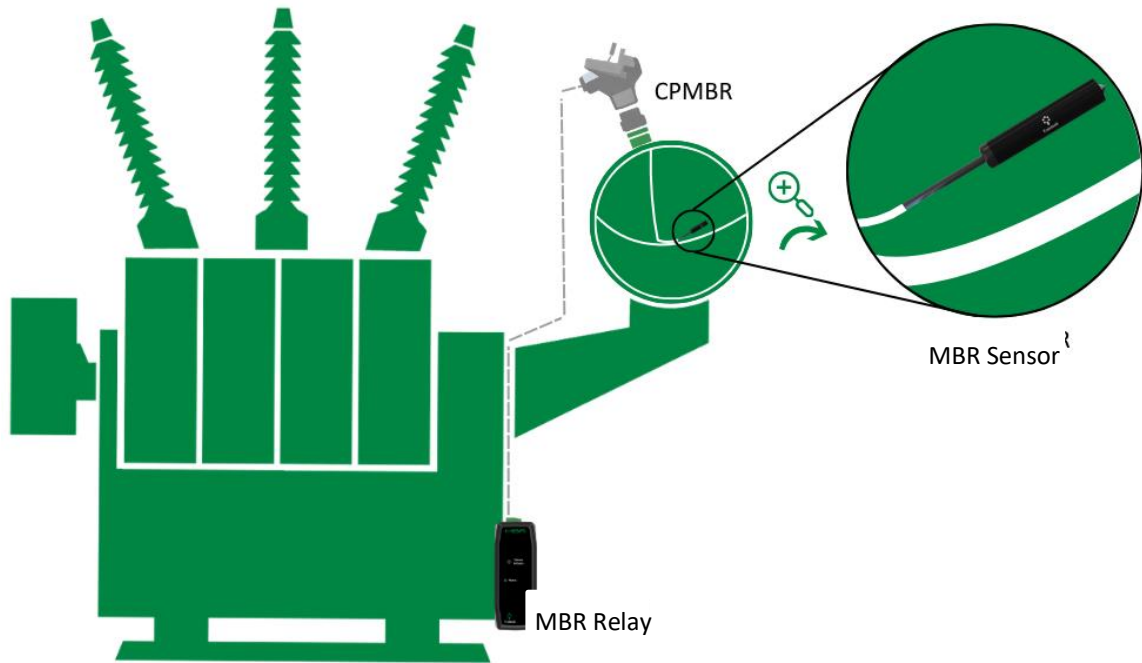

Figure 2 – Composition of the Membrane/Bladder Rupture Detection System

The items required for system installation are:

- Membrane/Bladder Rupture Relay – MBR;
- MBR sensor;
- MBR junction box (CP-MBR - optional);
- Two-way shielded twisted-pair cable for RS-485 serial communication.

3.2 Electrical Installation

Some special care must be taken when designing and installing the MBR, as described below:



Study and understand the application in which you intend to use the MBR. Know the functional, electrical and configuration characteristics of the MBR. This way you will be able to take full advantage of the equipment and minimize risks to your safety.



This equipment operates at dangerous power supply voltage levels, which may cause death or serious injury to the operator or maintainer.



A circuit breaker must be used immediately before the power input (Universal Power - 85 ~ 265 V AC/DC, ≤ 3 W, 50/60 Hz), which corresponds to pins 02 and 03 of the MBR.

The circuit breaker must have the number of poles corresponding to the number of phases used in the power supply, and the poles must only interrupt the phases, never the neutral or ground, and provide thermal and electrical protection to the conductors that supply the equipment. It must be close to the equipment and easily maneuverable by the operator.

Additionally, it must have an indelible identification showing that it is the MBR electrical disconnect device.



The following circuit breaker specification is recommended when used exclusively for the MBR:

- AC/DC power supply, Phase-Neutral: Single-pole circuit breaker, $1 \text{ A} \leq I_n \leq 2 \text{ A}$, curve B or C, standards NBR/IEC 60947-2, NBR/IEC 60898 or IEEE 1015-2006;
- AC/DC power supply, Phase-to-Phase: Bipolar circuit breaker, $1 \text{ A} \leq I_n \leq 2 \text{ A}$, curve B or C, standards NBR/IEC 60947-2, NBR/IEC 60898 or IEEE 1015-2006.



The minimum insulation for circuits connected to the MBR is 300 Vrms for auxiliary equipment and transducers and for self-powered equipment up to 50 Vrms.

The minimum insulation is 1.7 kVrms for equipment supplied with up to 300 Vrms, according to IEC 61010-1.

These values are relative to the intrinsic insulation of the devices connected to the MBR. Cases in which this value does not apply to equipment, or devices connected to the MBR will be explicitly informed in this manual.

3.3 Cable specification

Table 2 - Specification table

Cable specification		
Function	Specification	Observation
Power supply	1.5mm ² to 2,5mm ²	-
Relays	1.5 mm ² : Minimum gauge for signaling (self-diagnoses, alarms...)	Recommended according to the specification in NBR5410.
RS485/232	2x18AWG PVC Cable	It is recommended to consult the RS-485 Communication topic for more information.
MBR Sensor	Cable 4 x 0.5 mm ² , 200 °C	It is recommended to consult the Mechanical Installation topic for more information.

3.4 Connection diagram

The standard MBR connection schematic diagram shows all possible connections, identifying them as shown in the following figure.

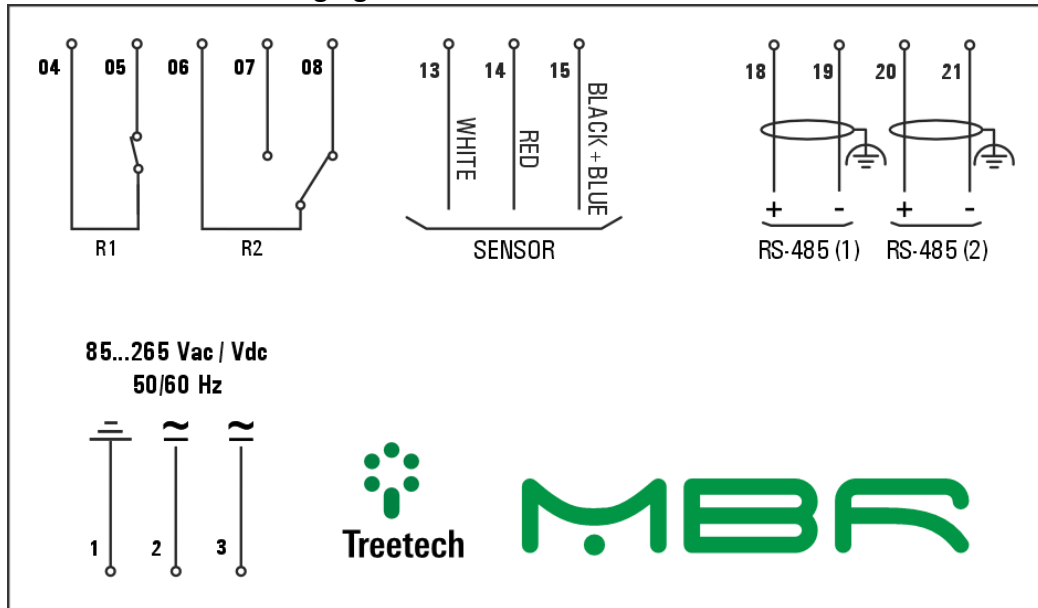

Figure 3 - MBR input and output terminals

Below, the CE marking is displayed, which identifies the product's conformity with the standards and technical requirements of the European Union.

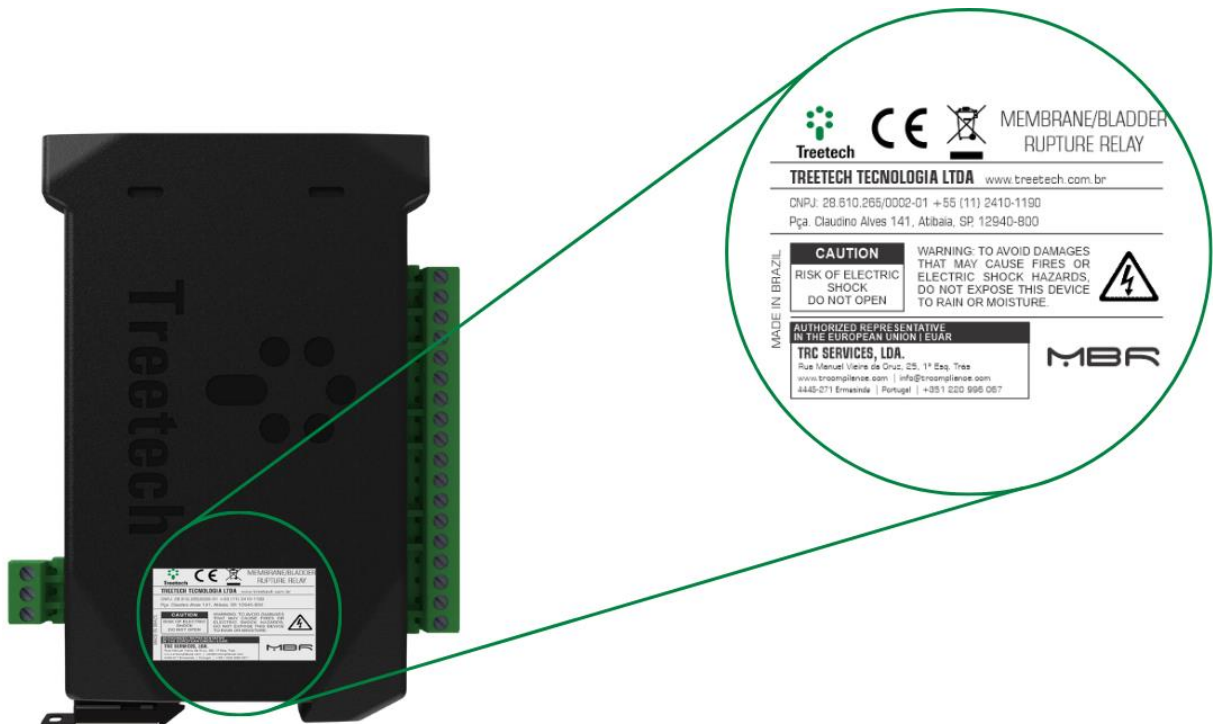

Figure 4 - CE certification label



3.4.1 Input and output terminals

The Membrane/Bladder Rupture Relay - MBR has the following inputs and outputs:

Table 3 - MBR input terminals

Inputs	Terminals
<p>Power and Grounding</p> <p>Power input 85 to 265 V DC/V AC, 50/60 Hz, ≤3 W.</p>	<p>01 — Ground 02 — dc/ac 03 — dc/ac</p>
<p>RS-485 Ports — Serial Communication Network with Monitoring or Supervisory System</p> <p>Connection to monitoring or supervisory system, using Modbus®RTU or DNP3 protocol.</p> <p>Use shielded twisted pair cable.</p>	<p>RS-485 (1) 18 — (+) 19 — (-)</p> <p>RS-485 (2) 20 — (+) 21 — (-)</p>
<p>MBR Sensor</p> <p>MBR optical sensor input.</p>	<p>13 — White 14 — Red 15 — Black + Blue</p>

Table 4 - MBR output terminals

Outputs	Terminals
<p>Relé 01 — Self-diagnosis</p> <p>A potential-free NC (Normally Closed) relay for self-diagnosis signaling.</p>	<p>04 e 05</p>
<p>Relé 02 — Membrane rupture alarm</p> <p>A reversible, potential-free relay for signaling membrane rupture alarm.</p>	<p>06 — Common 07 - NO 08 - NC</p>

3.4.2 Power and Grounding

The MBR has a universal power input (85 to 265 V AC/DC 50/60 Hz). Powering the MBR through the substation auxiliary services is advisable, especially when it is integrated into a communication network for data collection purposes for supervisory or monitoring systems.

3.4.3 Communication ports

3.4.3.1 RS-485 Communication

The MBR can be connected to a data acquisition system (supervisory or monitoring system) or to other IEDs through the RS-485 serial communication ports. Up to 31 devices can be interconnected in the same communication network. The communication protocols available for this connection are Modbus® RTU (master/slave) or DNP3 RTU (master/outstation).



The RS-485 serial communication network must be interconnected using a shielded twisted pair cable, keeping the mesh uninterrupted throughout the entire route. If intermediate terminals are needed to interconnect the serial communication, also pass the cable shield through the terminal, avoiding its interruption. The unshielded cable section due to splice must be as short as possible, and it is advisable that the cable shield be grounded at only one end. It is advisable to use a 120 Ω termination resistor at each end of the serial communication network to attenuate signal reflections.

In conjunction with the termination resistors, pull-up and pull-down resistors must be used at only one point in the network. The 5 V DC voltage to supply the pull-up and pull-down resistors can be internal to the data acquisition system or the IED. Note that some communication equipment may already have these resistors installed internally, eliminating the need for external resistors. The maximum distance of 1200 m between the ends of the communication network must be observed.

3.4.4 MBR sensor

It is an optical sensor that must be mounted on the membrane or inside the rubber bladder (air side). The sensor is provided with a polysulfone capsule containing an emitting LED and a trigger circuit.

3.4.5 Self-diagnosis relay

This relay is responsible for signaling failures in the MBR sensor connection, internal errors in the sensor or any internal failure detected by the self-diagnosis system. When the MBR is energized, the contact of this relay changes state, returning to the rest position in the event of the occurrence of the failures described.

3.4.6 Membrane rupture alarm relays

It is a reversible, potential-free relay with user-selectable NO (Normally Open) or NC (Normally Closed) initial logic. It is used to signal membrane rupture.



3.5 Mechanical Installation

The Membrane/Bladder Rupture Relay - MBR must be installed protected from the weather, either inside panels or sheltered inside buildings. In either case, an anti-condensation system must be installed.

The MBR must be installed on a 35 mm DIN rail. Figure 4 shows the main dimensions of the equipment. The connection terminals are installed on the top and bottom of the MBR in 2 removable connectors. Cables from 0.3 to 2.5 mm², 22 to 12 AWG, bare or with “pin” (or “needle”) type terminals can be used in the removable terminals.

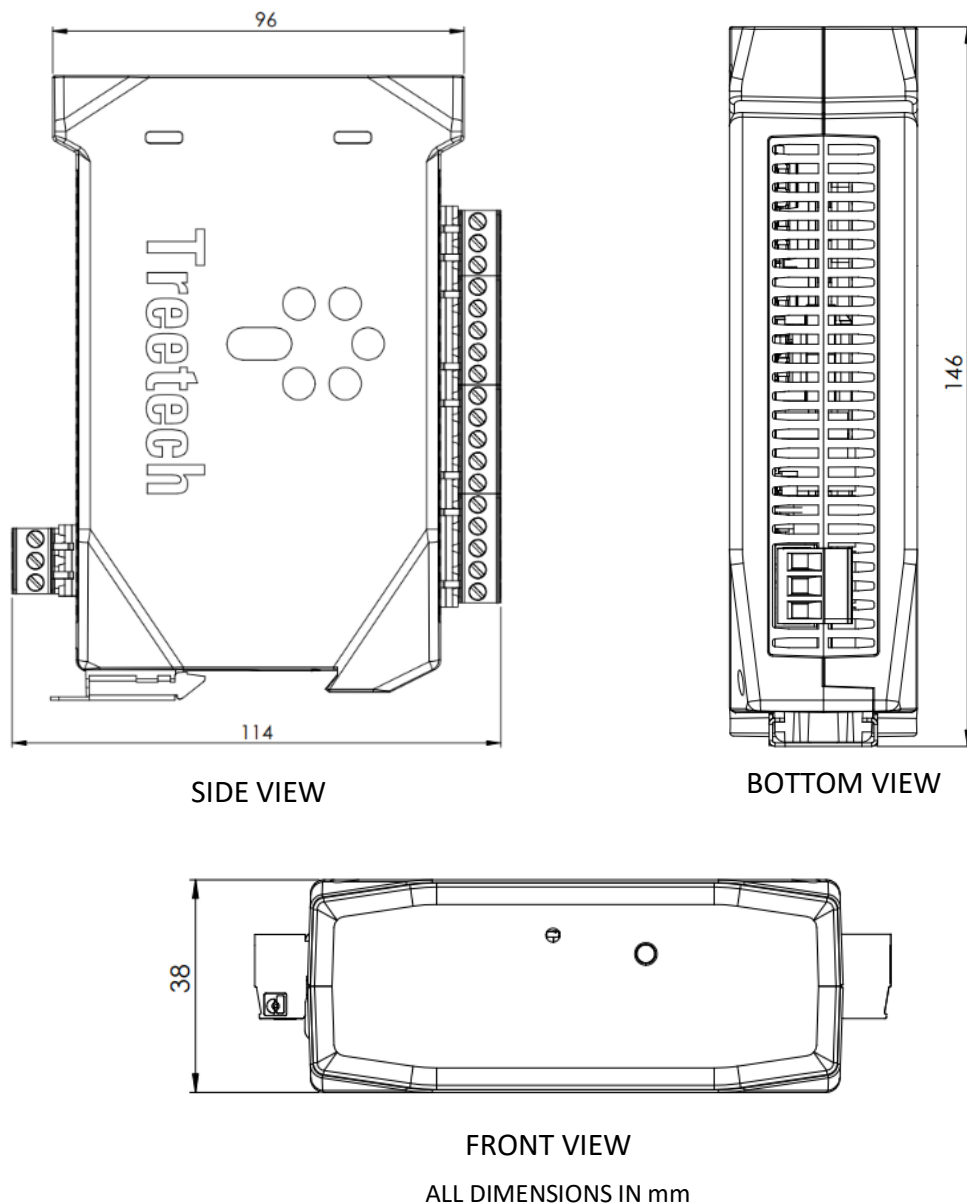
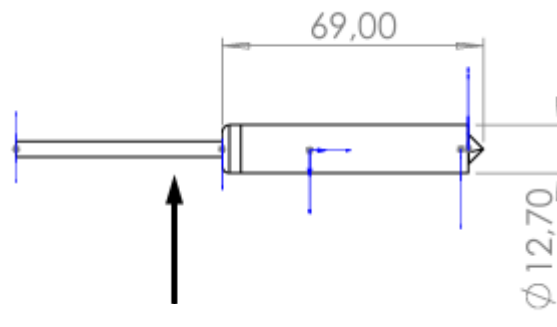

Figure 5 - Equipment dimensions – MBR

Figure 5 shows the dimensions of the MBR sensor:



Cable length = 5m

Figure 6 – MBR sensor dimensions

And figure 6 illustrates the Membrane/Bladder Rupture Relay and the MBR sensor:



Figure 7 – Membrane/Bladder Rupture Relay and MBR sensor

3.5.1 Pre-installation of CP-MBR

The CP-MBR is a signal junction box. It is mainly intended to provide the signal from the membrane/bladder rupture sensor inside the expansion/conservator tank to the MBR relay. Before disconnecting the transformer to carry out its installation, the next steps must be followed to avoid possible unforeseen events:

- A. Consult the technical drawings and, if possible, photos of the piping and access points to the transformer expansion tank;
- B. B. If you do not have access to the information highlighted in the previous item, a shutdown is necessary for the sole purpose of taking measurements and defining the CP-MBR installation point.

With the necessary information in hand, the CP-MBR installation place can be defined. To do this, the following guidelines should be considered when deciding the best location:

3.5.1.1 Use of the Bypass Collar directly on the pipe that reaches the expansion tank

The Bypass Collar is a device developed to facilitate the installation of the CP-MBR, replacing the need for installation on a flange for installation in a pipeline.



Below is a step-by-step guide to installing this accessory:

1. Remove duct

To facilitate installation, it is recommended to remove the tube that connects the expansion tank to the air dryer. As the tube is made up of two identical flanges, be careful which side the hole for the sensor will be drilled on.



Figure 8 – Duct

2. Drill hole

After removing the tube, use a 6 mm drill bit to drill a hole at a 45° angle and at a distance of 15 cm before the tube bend section. This angle is necessary to facilitate the passage of the sensor cable.



Warning: During the procedure, be careful not to drill the bottom of the tube with the drill bit. After drilling, remove the chips and burrs from the hole.



Figure 9 – Tube drilling

3. Cable routing

The sensor must be installed from the bottom up. To facilitate the passage of the sensor cable through the pipe, use an auxiliary cable tied to the sensor cable, to pull the sensor cable up to the hole.

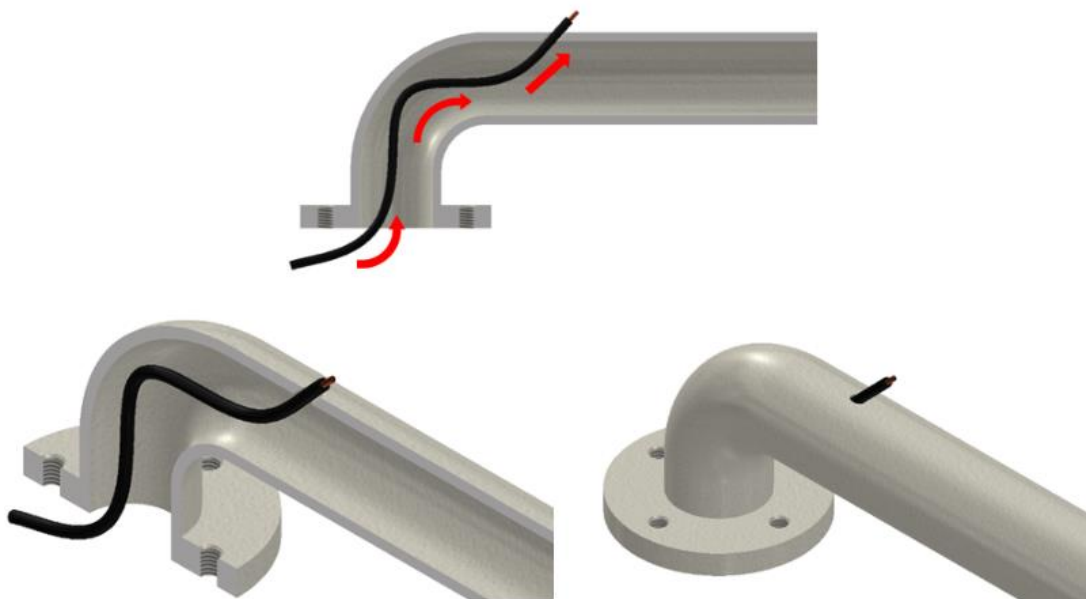

Figure 10 - Cable routing

4. Sealing

Once the cable has been pulled to the top, it is necessary to seal the hole. It is recommended that sealing tape be used.



Figura 11 - Sealing

5. Bypass collar

Then install the bypass collar on the pipe over the hole area.

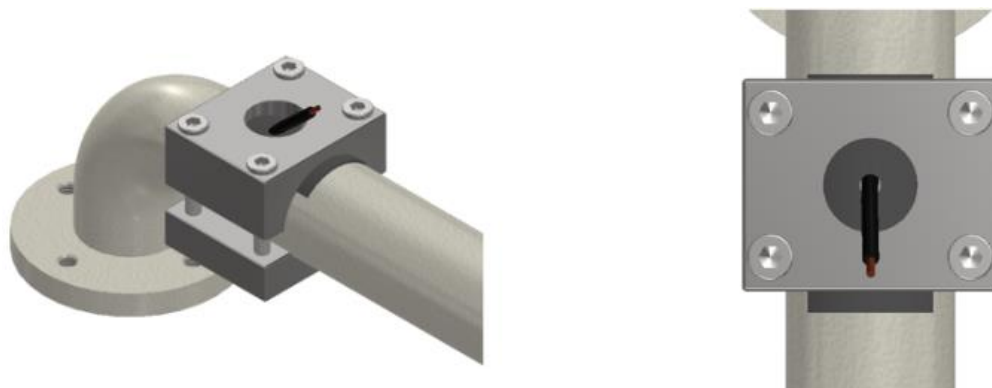

Figure 12 - Bypass collar



6. Head

Install the head and proceed with the sensor installation, as is normally done.



Figure 13 - Head

3.5.1.2 Connected directly to the expansion tank access point

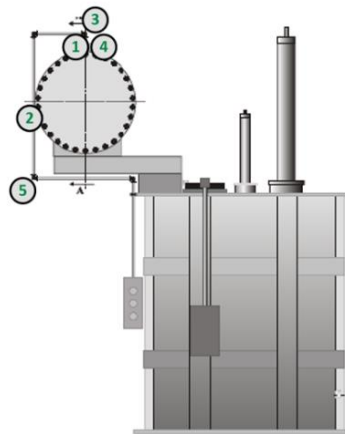

Figure 14 – Transformer

Connect the CP-MBR directly to the expansion tank access point (1) or to a “T” shaped point (2) very close by. In this case, no type of adaptation is necessary.

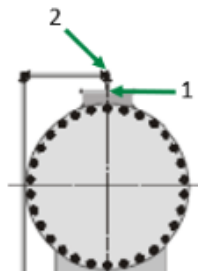

Figure 15 – Expansion tank access point



3.5.1.3 Connected to a “T” shaped access on the pipe leading to the expansion tank

Using a “T” shaped access, connect the CP-MBR to any point (other than the elbows) of the pipe leading to the bladder.



Figure 16 – “T” shaped access

3.5.1.4 Connected to expansion tank access point with threaded adapter

Connect the CP-MBR directly to the expansion tank access point or to a nearby “T” shaped point using a 3/4” BSP thread adapter.



Figure 17 – 3/4” BSP adapter

3.5.1.5 Hole in the expansion tank

Using a drill, make a 3/4” BSP hole in the expansion tank to connect the CP-MBR.

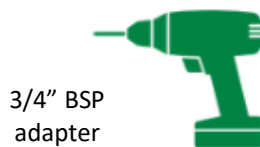

Figure 18 - Drill

3.5.1.6 Manufacturing of specific part for installation

The pipe that reaches the expansion tank has some parts commonly called “elbows”. To install the CP-MBR in these locations, it is recommended to manufacture a “T” shaped access on demand.



Figure 19 – “T” shaped access



3.5.2 CP-MBR Installation

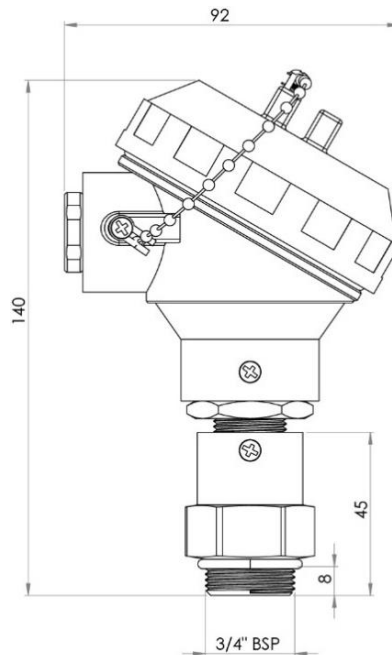

Figure 20 – CP-MBR dimensions

To install CP-MBR, simply follow the next steps:

1. Locate an access point to the inside of the expansion tank. Typically, pre-existing valves or threaded holes can be found in the conservator. If using these points is not an option, it will be necessary to create a threaded hole. To do this, use a drill and a tap. The standard thread used by the CP-MBR is 3/4" BSP. The threaded hole should provide access to the inside of the expansion bladder or to the dry surface of the oil separation membrane;

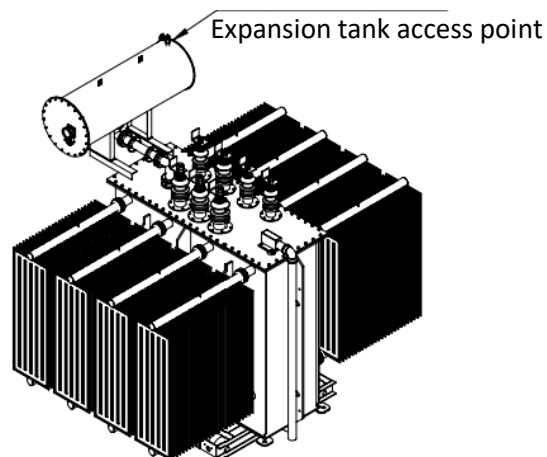

Figure 21 – Location of access point in expansion tank

2. Insert the MBR probe through the 3/4" BSP threaded hole. It is necessary to leave some excess cable inside the conservator so that the sensor remains in its correct position regardless of the oil level. Therefore, it is recommended that the cable exceeds the conservator diameter by approximately 1m (D+1 m).

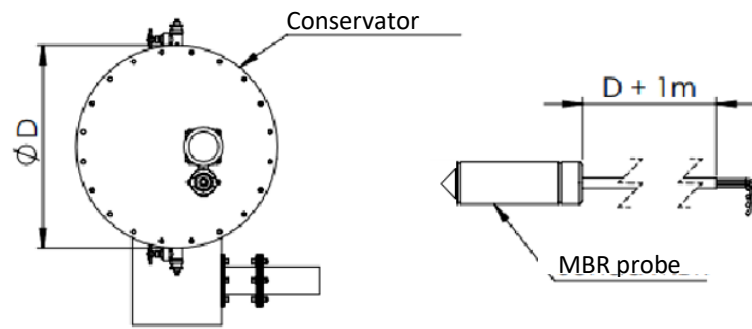

Figure 22 – Positioning of the MBR probe in the conservator

3. Screw on the base, which is approximated in the red circle, and then insert the MBR probe cable through: base, sealing rubber and washer. Leave about 50 cm of excess cable above the base;

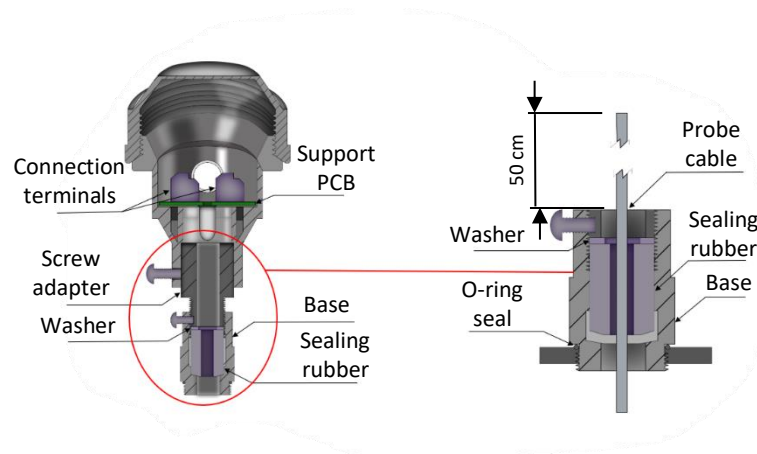

Figure 23 – CP-MBR base

4. Feed the cable into the head, making sure to pass through the support PCB. Then, screw the head firmly in place and tighten the base's safety screw;

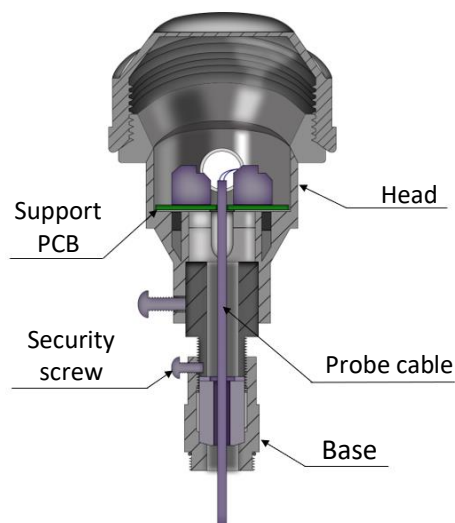

Figure 24 – Interior of CP-MBR

- Strip approximately 4 mm of each of the 4 conductors of the cable. Then, make the electrical connections following the diagram shown in Figure MBR Relay Connection terminals are spring-loaded, meaning that you simply insert the conductive part into their terminals. Therefore, using needle-type terminals is optional;

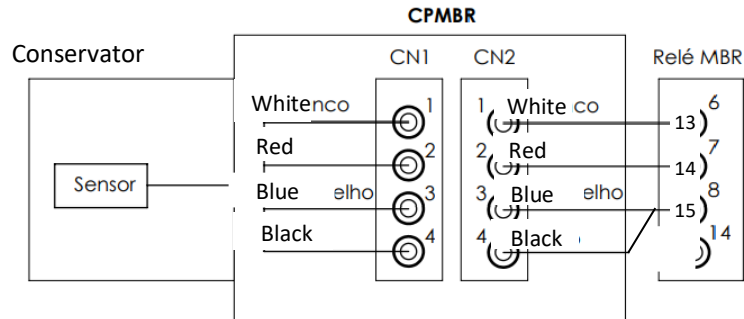

Figure 25 – Connection diagram

- Adjust the cables according to Figure 25 and check that all the cables are securely connected to the spring-loaded terminals. Finally, close the cover firmly and tighten the output cable gland.

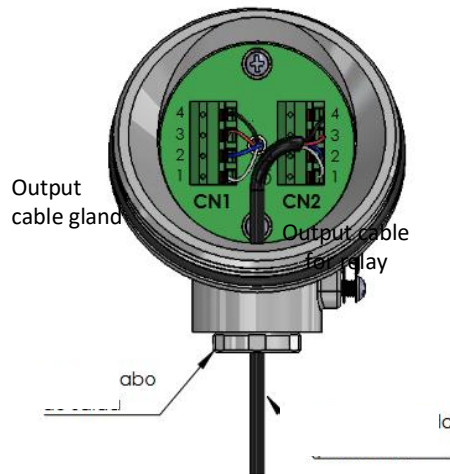

Figure 26 – Connecting cables to spring-loaded terminals



4 Operation

The equipment operation is divided into a button to load the communication parameters to default, a status indication LED, and the serial communication ports for configuration and monitoring via protocol.

4.1 Button function



Figure 27 – “Default Address” button

The button on the front of the MBR plays an essential role in allowing quick access to the equipment's default communication settings:

- ✓ Address:
 - Address RS 485 (1) – 201;
 - Address RS 485 (2) – 202;
- ✓ Baudrate RS 485 (1) and (2):
 - 9600 bps;
- ✓ Protocol: Modbus® RTU;

It is important to note that when pressing the button on the front of the MBR for at least 3 seconds, the LED will flash 5 times (in blue), indicating that the equipment is operating in standard communication mode.



4.2 Status LED

The MBR is equipped with a LED located on the front, which has crucial functions to indicate the status and communication of the device. When the board is powered on, the LED will display a cyan light for 5 seconds, indicating initialization, and then display a green light, indicating that the MBR is active. If an alarm is triggered, the LED will display a red light indicating that the alarm is on and a yellow light indicating active self-diagnosis. In all four cases, the activated light will remain flashing if its condition is true.

Table 5 - Front LED color code

Color	Function
Green	Indicates that the device is active Self-update: Fixed during migration from old to new bootloader
Red	Indicates that the alarm is on
Yellow	Indicates active self-diagnosis
Blue	Indicates feedback from some command (communication reset, default parameterization reset, alarm/self-diagnosis memory reset, etc.)
Cyan	Update via bootloader: Indicates update step 1 (device locked/waiting for command/waiting for reverse key)
Magenta	Update via bootloader: Indicates step 2 of the update (erasing the internal flash memory)
White	Update via bootloader: Indicates step 3 of the update (device unlocked/waiting for commands)

Note: If the alarm and self-diagnosis are active at the same time, the LED will alternate between red and yellow every 1 second.



5 Parameterization

To ensure correct system operation, some parameters must be adjusted in the MBR that will provide the equipment with the information necessary for its operation. The parameters in question refer to the configuration of the communication ports, clock and mass log.

The settings are made exclusively through the RS-485 communication ports, available to the user through the device terminals. Remember that to access these parameters, you must consult the register map of the selected protocol.

5.1 Key function

The only key present in the MBR is used to reconfigure the communication parameters to their default values. To do this, the key must be pressed for a minimum of 3 seconds. If the command was successful, the RGB LED will flash 5 times in Blue and the two communication interfaces (RS-485 (1) and RS-485 (2)) will be reconfigured.

5.2 RS-485 Serial Communication

This communication port has 2 isolated channels. The MBR can be connected to a data acquisition system (supervisory or monitoring system) or to other IEDs through the RS-485 serial communication ports. Up to 31 devices can be interconnected in the same communication network. The communication protocols available for this connection are Modbus® RTU (master/slave) or DNP3 RTU (master/outstation).

The RS-485 serial communication network must be interconnected using a shielded twisted pair cable, keeping the mesh uninterrupted throughout the entire route. If intermediate terminals are needed to interconnect the serial communication, also pass the cable shield through the terminal, avoiding its interruption. The unshielded cable section due to the splice must be as short as possible, and it is advisable that the cable shield be grounded at only one end. It is advisable to use a 120 Ω termination resistor at each end of the serial communication network to attenuate signal reflections.

To facilitate reading and changing data, some software for serial communication is recommended, as we can see below.

5.2.1 Communication with Modbus or DNP3 protocol

It is possible to use the Membrane/Bladder Rupture Relay MBR and its protocol map to illustrate data reading through the RMMS (Modbus) or SPA1 (DNP3) software. To perform this procedure, the equipment must already be communicating with the software. Follow the instructions by clicking on the link below or scanning the QR code to be directed to the Modbus communication procedure with RMMS software or DNP3 communication protocol with SPA1 software.



RMMS



SPA1



5.3 User control access

Confirmation key

Parameter for confirmation key to apply serial parameterization

To apply the serial parameter settings, it is necessary to confirm the operation using the confirmation key. Parameter settings can only be applied via the protocol.

Adjustment range: 0 to 65535

Default: 0

Fixed value: 43605

User login password

Parameter for user access request

Adjusts the user access request parameter.

Adjustment range: YES or NO

Default: NO

Parameter for user password entry

User password input parameter.

Adjustment range: 0 to 9999

Default: 0

5.4 System and control

Allows you to configure the system date and time in UTC format.

Command to apply clock settings

Adjustment range: YES or NO

Default: NO

UTC time

UTC time – Year

Adjusts the year.

Adjustment range: 2000 to 2099

Default: 2000



UTC time – Month

Adjusts the month.

Adjustment range: 1 to 12

Default: 1

UTC time – Day

Adjusts the day.

Adjustment range: 1 to 31

Default: 1

UTC time – Hour

Adjusts the hour.

Adjustment range: 0 to 23

Default: 0

UTC time – Minute

Adjusts the minutes.

Adjustment range: 0 to 59

Default: 0

UTC time – Second

Adjusts the seconds.

Adjustment range: 0 to 59

Default: 0

Time zone

Sets the time zone offset in hours relative to UTC.

Adjustment range: -12 to 12

Default: -3

5.5 General

Parameter for user login password configuration

Sets the user's login password.

Adjustment range: 0 to 9999

Default: 0

Note: The current password is only displayed when user access control is enabled.

Parameter for periodic saving of mass log

Defines the interval for periodic saving of the mass log.

Adjustment range: 1 to 9999 min

Default: 720 min

5.5.1 Maintenance and Cleaning

Command to reset alarm memory

Adjustment range: YES or NO

Default: NO



Command to reset self-diagnosis memory

Adjustment range: YES or NO

Default: NO

5.5.2 Advanced

Command to restore the default values of user parameters

Adjustment range: YES or NO

Default: NO

Command to reset the mass log

Adjustment range: YES or NO

Default: NO

5.6 UART

Parameter for BAUDRATE of UART 1

Parameter that defines the transmission rate of UART 1.

Adjustment range:

- 4.800 bps;
- 9.600 bps;
- 19.200 bps;
- 38.400 bps;
- 57.600 bps;
- 115.200 bps.

Default: 9.600 bps.

Parameter for protocol associated with UART 1

Parameter that defines the protocol associated with UART 1.

Adjustment range: Modbus or DNP3

Default: Modbus

Note: Both RS-485 ports support simultaneous DNP3 configuration.

Parameter for UART 1 address

Parameter that defines the address of UART 1.

Adjustment range: 1 to 65519

Default: 201

Note: The maximum limit depends on the selected protocol: 247 for Modbus and 65519 for DNP3.

Parameter for interval for detecting the end of reception from UART 1

Parameter that defines the interval for detecting the end of reception of UART 1.

Adjustment range: 5 ms to 500 ms

Default: 5 ms

Parameter for delay interval before UART 1 transmission

Parameter that defines the delay interval before UART 1 transmission.

Adjustment range: 5 ms to 500 ms

Default: 25 ms



Parameter for UART 1 confirmation key

Parameter that defines the confirmation key for UART 1.

Adjustment range: 0 to 65535

Default: 0

Parameter for BAUDRATE of UART 2

Parameter that defines the transmission rate of UART 2.

Adjustment range:

- 4.800 bps;
- 9.600 bps;
- 19.200 bps;
- 38.400 bps;
- 57.600 bps;
- 115.200 bps.

Default: 9.600 bps.

Parameter for protocol associated with UART 2

Parameter that defines the protocol associated with UART 2.

Adjustment range: Modbus or DNP3

Default: Modbus

Note: Both RS-485 ports support simultaneous DNP3 configuration.

Parameter for UART 2 address

Parameter that defines the address of UART 2.

Adjustment range: 1 to 65519

Default: 202

Note: The maximum limit depends on the selected protocol: 247 for Modbus and 65519 for DNP3.

Parameter for interval for detecting the end of reception from UART 2

Parameter that defines the interval for detecting the end of reception of UART 2.

Adjustment range: 5 ms to 500 ms

Default: 5 ms

Parameter for delay interval before UART 2 transmission

Parameter that defines the delay interval before UART 2 transmission.

Adjustment range: 5 ms to 500 ms

Default: 25 ms

Parameter for UART 2 confirmation key

Parameter that defines the confirmation key for UART 2.

Adjustment range: 0 to 65535

Default: 0



6 Commissioning for entry into service

Once the equipment has been installed in accordance with the instructions in this manual, commissioning must follow the basic steps below:

- ✓ Check mechanical and electrical installations;
- ✓ Using a multimeter, check that the equipment is connected correctly;
- ✓ Connect the ground cable to terminal 1 of the MBR;
- ✓ Power the MBR at terminals 2 and 3 with a supply voltage of 85 to 265 Vac/Vdc, 50/60 Hz;
- ✓ Using a computer, communication converters and appropriate software, as applicable, check the operation of the MBR communication ports according to the application used;
- ✓ Simulate the operation of monitored external contacts and observe whether the outputs are operating correctly according to the programming.



7 Troubleshooting

Troubleshooting Membrane/Bladder Rupture Relay (MBR) involves identifying and correcting issues related to the communication and network configuration of devices connected to it.

It is essential that the MBR user pays attention to the color of the LED located on the front of the equipment. The LED plays an important role in signaling communication problems and alerts, providing visual information about the status of the system.

The LED has different colors, such as green, red, yellow, blue, cyan, magenta and white, each indicating a specific status. For example, the green LED indicates that the equipment is active, while the red LED indicates the equipment alarm, and the yellow LED informs that some self-diagnosis is active. The blue LED signals the feedback of some command. It is also possible to consult the color code in Table 5.

Observing the LED color and associating it with specific issues can help quickly identify communication failure situations. This information can be used as an early indicator to guide troubleshooting steps and direct appropriate action, whether that means performing additional checks on connected devices, network configurations, or contacting the appropriate technical support.

If, after these checks, the problem persists and cannot be resolved internally, it is recommended to contact Treotech Customer Service (CS). CS is prepared to deal with technical issues related to the MBR and offer additional support in resolving more complex problems.

It is important to emphasize the importance of following the manufacturer's guidelines and using the support resources provided. By relying on the support of Treotech CS, it is possible to obtain specialized assistance and ensure an efficient troubleshooting process in the MBR, minimizing interruptions and maintaining the proper functioning of the communication system.

7.1 Viewing self-diagnosis memory and alarm memory

To view the self-diagnostic and alarm memory, it is necessary to consult the map of the protocol used. This option allows you to detail which errors were triggered, and whether they are still active.



8 Technical data

Table 6 - Technical data

Hardware	Range/description
Supply voltage	85...265 Vac/Vdc
Frequency	50/60 Hz
Maximum consumption	≤3 W
Operating temperature	-40...85 °C
Degree of protection	IP20
Connections	0,3...2,5 mm ² , 22...12 AWG
Fixing	DIN rail (35mm)
Measurement inputs	
1 MBR Sensor (required)	Operating temperature: -40...+100 °C
	Degree of protection: IP67
	Cable: 4 x 0.5mm ² , 200°C
Outputs	
Relay outputs	1 NC (Normally Closed) relay + 1 NO and NC (Normally Open and Normally Closed) relay
Dielectric strength	1000 Vrms between contacts 4000 Vrms between contact and coil
Maximum switching voltage	400 Vac 30 Vdc
Maximum switching current	5,0 A @ 250 Vac 5,0 A @ 30 Vdc
Maximum switching power	1250 VA
Resistive load	1,0 A @ 60 Vdc; 60 W 2,0 A @ 40 Vdc; 80 W
Communication interface	
Communication protocols	DNP3 Modbus® RTU
Communication ports	2 RS-485 (based on TIA-485-A standard)
Dimension and weight	
Dimension	38mm x 114 mm x 146 mm
Weight	250 grams



9 Ordering specification

1. Product name

- Membrane/Bladder Rupture Relay – MBR.

2. Quantity

- Number of relay units.

3. Communication protocol

- Specify the communication protocol to be configured in the MBR:
 - ✓ Modbus® RTU;
 - ✓ DNP3;

4. MBR Sensor

a. Quantity

- Number of MBR sensor units;

b. Cable length

- The length of the MBR sensor cable must be specified. The default is 5 meters.

5. Accessories

a. Quantity

- Number of **junction box** units (**CP-MBR**) must be specified;

b. Thread

- Thread option: Standard 3/4" BSP (British Standard Pipe) or optional 3/4" NPT (National Pipe Thread).



Treotech[®]

Treotech Tecnologia
Rua José Alvim, 112, Centro
CEP 12940-750 – Atibaia/SP
+55 11 2410 1190
www.treotech.com.br