

MANUAL DO PRODUTO



Treetech

TM1/TM2

Temperature Monitor



Contents

1	Preface	6
1.1	Legal information.....	6
1.1.1	Disclaimer.....	6
1.2	Presentation.....	6
1.3	Typographical conventions	6
1.4	General and safety information.....	6
1.4.1	Safety symbols.....	7
1.4.2	General symbols	7
1.4.3	Minimum recommended profile for the TM1/TM2 operator and maintenance personnel	7
1.4.4	Environmental and voltage conditions required for installation and operation	8
1.4.5	Instructions for testing and installation	8
1.4.6	Instructions for cleaning and decontamination.....	9
1.4.7	Instructions for inspection and maintenance.....	10
1.5	Customer service	11
1.6	Warranty terms	12
2	Introduction	13
2.1	Features and functions	14
2.1.1	Inputs.....	15
2.1.2	Outputs	15
2.1.3	Communication	15
2.2	Optional functions	16
2.2.1	DNP3 - DNP3 Protocol.....	16
2.2.2	PCOL - Pre-cooling	16
2.2.3	FEXC - Daily cooling activation.....	16
2.2.4	OLTDC - OLTC temperature differential	16
2.2.5	MMEM - Mass memory (default)	17
2.3	Basic operating philosophy	18
2.3.1	On-load tap changer temperature differential (optional).....	18
3	Design and installation	20
3.1	System topology	20
3.2	Electrical installation.....	22
3.2.1	Input and output terminals	24
3.2.2	RTD temperature sensors	27
3.2.3	RS-485 serial communications.....	28
3.2.4	Analog outputs	28
3.2.5	Current transformers	29
3.2.6	Forced cooling control	30
3.2.7	Typical application diagrams	38
3.3	Mechanical installation	41
4	Operation	43
4.1	Initial indications	43
4.2	Key functions.....	44
4.3	Query screens.....	45
4.3.1	TM1 query screens	45
4.3.2	TM2 query screens	48
4.4	Commands	49
5	Parameterization.....	50
5.1	Access to programming menus	50
5.2	Parameter map.....	51



5.3	LNG Menu	52
5.4	RLG Menu.....	52
5.5	ALM Menu.....	53
5.5.1	ALM Menu - TM1.....	53
5.5.2	ALM Menu - TM2.....	54
5.6	CNF Menu.....	56
5.6.1	CNF Menu - TM1.....	56
5.6.2	CNF Menu - TM2.....	61
5.7	TRF Menu	64
5.7.1	TRF Menu - TM1	65
5.7.2	TRF Menu - TM2	66
5.8	RF Menu.....	68
5.8.1	CONF Submenu.....	68
5.8.2	ER1, ER2, ER3 and ER4 Submenus	70
5.9	DTC Menu (optional).....	71
5.10	LOG Menu	73
6	Commissioning for entry into service	75
6.1	Parameterization sheet.....	76
7	Troubleshooting	77
7.1	The equipment displays self-diagnosis messages on the screen	77
8	Technical data and type tests	79
8.1	Technical data.....	79
8.2	Type tests	81
9	Specification for order.....	82



Illustrations

Figure 1 - Temperature Monitors - TM1/TM2.....	13
Figure 2 - Temperature measurements of the OLTC, transformer, and temperature differential.....	19
Figure 3 - Instantaneous and filtered temperature differentials.....	20
Figure 4 - Block diagram	21
Figure 5 - TM1 wiring diagram	23
Figure 6 - TM2 wiring diagram	24
Figure 7 - Shielding connection for the interconnection between RTD sensors and TM1/TM2	27
Figure 8 - TM1/TM2 input and output terminals in their default configuration	28
Figure 9 - Detail of correctly connecting transformers directly to the Temperature Monitors	29
Figure 10 - Detail of the connection of current transformers to Temperature Monitors for external sectionable core CTs.....	30
Figure 11 - Control system for 4 identical forced cooling groups, with alternating operation of the groups.....	32
Figure 12 - Control system for 1 forced cooling group with pumps and 3 identical groups with alternating operation of the fan groups.....	33
Figure 13 - Control system for 2 identical forced cooling groups with pumps and 2 identical groups with fans, with independent alternation of operation between pump groups and fan groups.....	34
Figure 14 - Control system for 4 identical forced cooling groups in 2 temperature stages, with timing at engine start-up and alternation between groups	36
Figure 15 - Control system for 2 identical forced cooling groups with redundancy in the command	37
Figure 16 - Option 1 - 2 RTDs with 3 wires.....	38
Figure 17 - Option 2 - 1 RTD with 4 wires	38
Figure 18 - Option 3 - 1 RTD with 3 wires, RTD "A"	39
Figure 19 - Option 4 - 1 RTD with 3 wires, RTD "B"	39
Figure 20 - TM1/TM2 connection diagram	40
Figure 21 - TM1/MT2 connection diagram	40
Figure 22 - TM1 connection to IRIG-B synchronization signal.....	41
Figure 23 - TM1 and TM2 dimensions	42
Figure 24 - Indications on TM1/TM2	43
Figure 25 - TM1 signaling LEDs.....	43
Figure 26 - TM2 signaling LEDs.....	44
Figure 27 - Indications of self-diagnosis.....	77



Tables

Table 1 - Operating conditions.....	8
Table 2 - TM1/TM2 input terminals.....	24
Table 3 - TM1/TM2 output terminals.....	26
Table 4 - Programming the cooling stages.....	30
Table 5 - TM1/TM2 key functions	44



1 Preface

1.1 Legal information

The information contained in this document is subject to change without notice.

This document belongs to Treetech Tecnologia Ltda. and may not be copied, transferred to third parties, or used without express authorization, in accordance with Brazilian Law 9.610/98.

1.1.1 Disclaimer

Treetech Tecnologia reserves the right to make changes without prior notice to all products, circuits, and functionalities described herein in order to improve their reliability, function, or design. Treetech Tecnologia assumes no responsibility resulting from the application or use of any product or circuit described herein, nor does it transfer any licenses or patents under its rights, nor the rights of third parties.

Treetech Tecnologia Ltda. may hold patents or other types of registrations and intellectual property rights described in the content of this document. Possession of this document by any person or entity does not grant them any rights to these patents or registrations.

1.2 Presentation

This manual provides all recommendations and instructions for the installation, operation, and maintenance of the Temperature Monitor - TM1/TM2.

1.3 Typographical conventions

Throughout this text, the following typographical conventions have been adopted:

Bold: Symbols, terms, and words in bold have greater contextual importance. Therefore, pay attention to these terms.

Italics: Foreign language terms, alternative terms, or terms used outside of formal situations are placed in italics.

Underlined: References to external documents.

1.4 General and safety information

This section will present relevant aspects regarding the safety, installation, and maintenance of TM1/TM2.



1.4.1 Safety symbols

This manual uses three types of risk classification, as shown below:



Warning:

This symbol is used to alert the user to a potentially dangerous operational or maintenance procedure that requires greater care in its execution. Minor to moderate injuries may occur, as well as damage to equipment.



Attention:

This symbol is used to alert the user to a potentially dangerous operational or maintenance procedure where extreme caution must be exercised. Serious injury or death may occur. Possible damage to equipment will be irreparable.



Risk of electric shock:

This symbol is used to alert the user to an operational or maintenance procedure that, if not strictly followed, could result in electric shock. Mild, moderate, or severe injury or death may occur.

1.4.2 General symbols

This manual uses the following general-purpose symbols:



Important

This symbol is used to highlight information.



Tip

This symbol represents instructions that facilitate the use of or access to functions in the TM.

1.4.3 Minimum recommended profile for the TM1/TM2 operator and maintenance personnel

The installation, maintenance, and operation of equipment in electrical substations require special care; therefore, all recommendations in this manual, applicable standards, safety procedures, safe work practices, and good judgment must be used during all stages of handling the Temperature Monitor - TM1/TM2.



Only authorized and trained personnel, operators and maintenance staff should handle this equipment.

To handle the TM1/TM2, the professional must:

1. To be trained and authorized to operate, ground, start and shut down TM1/TM2, following maintenance procedures in accordance with established safety practices, which are the sole responsibility of the TM operator and maintainer;
2. Being trained in the use of PPE (Personal Protective Equipment), CPE (Collective Protective Equipment), and first aid;
3. Being trained in the operating principles of TM1/TM2, as well as its configuration;
4. Follow the regulatory recommendations regarding interventions on any type of equipment within an electrical power system.

1.4.4 Environmental and voltage conditions required for installation and operation

The following table lists important information regarding environmental and voltage requirements.

Table 1 - Operating conditions

Condition	Range/description
Application	Equipment for indoor use in substations, industrial environments and similar settings
Indoor/outdoor use	Indoor use
Degree of protection (IEC 60529)	IP20
Altitude* (IEC EN 61010-1)	Up to 2000 m
Temperature (IEC EN 61010-1)	
Operation	-40...+85 °C
Storage	-40...+95 °C
Relative humidity (IEC EN 61010-1)	
Operation	5...95% - Non-condensing
Storage	3...98 % - Non-condensing
Voltage fluctuation of the power supply (IEC EN 61010-1)	Up to ±10% of nominal voltage
Overvoltage (IEC EN 61010-1)	Category II
Pollution rating (IEC EN 61010-1)	Degree 2
Atmospheric pressure ** (IEC EN 61010-1)	80...110 kPa

* Altitudes above 2000 m already have successful applications.

** Pressures below 80 kPa already have successful applications.

1.4.5 Instructions for testing and installation

This manual should be available to those responsible for the installation, maintenance, and users of the Temperature Monitor - TM1/TM2.



To ensure user safety, equipment protection, and proper operation, the following minimum precautions must be followed during the installation and maintenance of the TM1/TM2.

1. Read this manual carefully before installing, operating, and maintaining the TM1/TM2. Errors in the installation, maintenance, or adjustments of the TM1/TM2 may cause false alarms, failure to issue relevant alarms, and thus lead to misunderstanding of the transformer's actual health and operational status.
2. The installation, adjustments, and operation of TM1/TM2 must be performed by personnel trained and familiar with power transformers with mineral or vegetable oil insulation, control devices, and control circuits for substation equipment.
3. Special attention should be paid to the installation of the TM1/TM2, including the type and gauge of the cables, the installation location and commissioning, including the correct parameterization of the equipment.
4. When performing dielectric strength tests on the wiring (applied voltage), disconnect the ground cables connected to terminal 13 of the TM1 and TM2 Temperature Monitors to avoid destruction of the overvoltage protections inside the devices due to the application of high voltages for a long period (e.g., 2 kV for 1 minute). These protections are internally connected between the input/output terminals and ground, clamping the voltage at approximately 300 V.



The TM1/TM2 must be installed in a sheltered environment (a doorless panel in a control room or an enclosed panel in the case of outdoor installation) that does not exceed the temperature and humidity specified for the equipment.



Do not install the TM1/TM2 near heat sources such as heating resistors, incandescent lamps, and high-power devices or devices with heat sinks. Installation near ventilation openings or where it may be exposed to forced airflow, such as the inlet or outlet of cooling fans or forced ventilation ducts, is also not recommended.



If the panel where the TM1/TM2 is installed has a window, use a G20 film – or higher – to prevent direct sunlight (ultraviolet rays) from reaching the equipment. If the window glass is dark, this procedure is not necessary.

1.4.6 Instructions for cleaning and decontamination

Be careful when cleaning the TM1/TM2. Use ONLY a damp cloth with soap or detergent diluted in water to clean the housing, faceplate, or any other part of the equipment. Do not



use abrasive materials, polishes, or harsh chemical solvents (such as alcohol or acetone) on any of its surfaces.

1.4.7 Instructions for inspection and maintenance

For inspection and maintenance of TM1/TM2, the following observations should be followed:



Do not open your equipment. There are no user-serviceable parts inside. This must be done by Treetech technical support, or technicians accredited by them. This equipment is completely maintenance-free, and visual and operational inspections, periodic or not, can be carried out by the user. These inspections are not mandatory.



All parts of this equipment must be supplied by Treetech, or one of its authorized suppliers, according to its specifications. If the user wishes to acquire them in another way, they must strictly follow Treetech's specifications for this. This will ensure that the performance and safety of both the user and the equipment are not compromised. Failure to follow these specifications may expose the user and the equipment to unforeseen risks.



Opening the TM1/TM2 at any time will void the product warranty. In cases of improper opening, Treetech will also not be able to guarantee its correct functioning, regardless of whether the warranty period has expired or not.



1.5 Customer service

Are you already familiar with our online customer service platform?

[CS](#)



On the SAC page, you'll find a quick and direct communication channel with our support team. Get your questions answered, resolve problems, and keep your Treetech product application up-to-date.

The Treetech knowledge base is also available, including catalogs, manuals, application notes, frequently asked questions, and more.



In some cases, it will be necessary to send the equipment to Treetech's Technical Assistance. Our Customer Service department will explain the entire procedure and provide the necessary contact information.



1.6 Warranty terms

The TM1/TM2 Temperature Monitor will be guaranteed by Treetech for a period of 2 (two) years, starting from the date of purchase, exclusively against any manufacturing defects or quality flaws that render it unsuitable for regular use.

The warranty will not cover damage to the product resulting from accidents, mistreatment, improper handling, incorrect installation and application, inadequate testing, or if the warranty seal is broken.

Any need for technical assistance should be communicated to Treetech or its authorized representative, presenting the equipment along with the corresponding proof of purchase.

Treetech provides no express or implied warranty other than those stated above. Treetech does not provide any warranty of suitability of TM1/TM2 for a particular application.

The seller shall not be liable for any type of property damage or for any losses and damages arising from, connected with, or resulting from the purchase of the equipment, its performance, or any service possibly provided in conjunction with the TM1/TM2.

Under no circumstances shall the seller be liable for any losses incurred, including but not limited to: loss of profits or income, inability to use the TM1/TM2 or any associated equipment, capital costs, costs of purchased energy, costs of substitute equipment, installations or services, downtime costs, claims from the buyer's customers or employees, regardless of whether such damages, claims or losses are based on contract, warranty, negligence, tort or otherwise. Under no circumstances shall the seller be liable for any personal injury of any kind.



2 Introduction



Figure 1 - Temperature Monitors - TM1/TM2

Treotech's TM1 and TM2 Temperature Monitors form a complete system for temperature monitoring in oil-immersed transformers and reactors. Being a modular system, it can be used in simple, low-cost applications as well as in complete monitoring systems. The system consists of the TM1 and TM2 modules:

TM1 - Monitors the temperature of the oil and one winding. It is equipped with:

- Configurable input for a 4-wire RTD sensor for oil temperature, or two 3-wire sensors for redundant oil temperature measurement or simple measurement of oil temperature and an additional temperature (e.g., ambient or on-load tap changer);
- A load current measurement input, for calculating winding temperature.

TM2 - Used as a complement to the TM1, it monitors the temperature of one or two additional windings. It is equipped with:

- Two load current measurement inputs, for calculating the temperatures of two additional windings;
- Configurable input for a 4-wire RTD sensor, a 3-wire sensor on input A, a 3-wire sensor on input B, or two 3-wire sensors on inputs A and B, for measuring additional temperatures (e.g., ambient, on-load tap changers, or others).

In addition to these basic functions, the TM1 and TM2 monitors offer several optional features that complement asset monitoring. See optional functions below.



2.1 Features and functions

Measurement of oil temperature

Measuring the temperature of the oil top using a 3-wire Pt100 sensor, a 4-wire Pt100 sensor, or two 3-wire Pt100 sensors (redundant temperature measurement and measurement validation).

Indirect measurement of winding temperature

Temperature measurement of up to three windings using algorithms based on standards and transformer parameters.

LED displays

High-brightness 4-digit LED displays for easy viewing in any lighting conditions.

Robust hardware

The TM1/TM2 design exceeds EMC (Electromagnetic Compatibility) standards to withstand harsh electromagnetic conditions in substations and operating temperatures from -40 to 85 °C.

Final gradient prediction

Calculation of the predicted final oil-winding temperature gradient for the ongoing load.

Local cooling control

Cooling operation selectable via front keypad, in automatic or manual mode, or remotely via communication protocol.

Uniform use of fans and pumps

Automatic alternation of forced cooling units in pre-programmed stages, based on their operating times, providing uniform use of fans and/or pumps.

Internal clock

Internal clock with settings maintained for 48 hours in case of power failure, without the use of batteries; maintenance-free equipment.

Compact and versatile

The TM1/TM2 has compact dimensions, providing space savings and reduced installation costs.

Self-diagnosis

Self-diagnosis of internal faults and integration with peripheral equipment, with display indication next to a dry contact relay.



2.1.1 Inputs

- ✓ Inputs for Pt100 sensors with self-calibration, 0.2% full-scale accuracy, and high stability over a wide ambient temperature range.
- ✓ Universal AC current inputs True RMS from 0 to 10 A, 0.5% full-scale accuracy for load measurement and winding temperature calculation by thermal imaging. Optional external sectional window CT.

2.1.2 Outputs

- ✓ NO (Normally Open) contacts (NC or combinations on request) for oil or winding temperature alarms;
- ✓ Normally open (NO) contacts for shutdowns due to oil and winding temperatures, with double safety on activation (simultaneous command from both microcontrollers for operation). Adjustable timing from 0 to 20 minutes with countdown display;
- ✓ Normally closed (NC) contacts for activating up to 4 forced cooling groups (using TM1 and TM2) with timing between group start-up (even with power failure to TM1 or TM2) and forced operation by self-diagnostic routines in case of failure or power outage;
- ✓ Normally closed (NC) contacts for indication of internal fault or lack of voltage detected by self-diagnosis.;
- ✓ Normally open (NO) contacts for indicating entry into counting mode for tripping or triggering a temperature differential alarm for the on-load tap changer(s) (optional);
- ✓ Current outputs for remote temperature indications, with selection of the output range (0...1, 0...5, 0...10, 0...20 or 4...20 mA).

2.1.3 Communication

- ✓ 1 RS-485 serial communication port;
- ✓ 1 RS-232 serial communication port;
- ✓ Modbus® communication protocol, DNP3 (see optional below), with timestamp support, capable of signaling events such as alarms, shutdowns, cooling activation, etc., with 1 ms accuracy.



2.2 Optional functions

Depending on the request, the TM can be supplied with one or more of the following optional functions:

2.2.1 DNP3 - DNP3 Protocol

User-selectable communication protocol between Modbus and DNP3, with support for timestamping with 1 ms precision.

2.2.2 PCOL - Pre-cooling

Extends insulation life by activating cooling units when user-selected load levels are reached. Taking advantage of the oil's high thermal inertia, forced cooling is activated before the temperature rises excessively, reducing winding exposure to high temperatures and increasing insulation life. These are user-programmable:

- ✓ Percentage of load for individual activation of each forced cooling stage, in up to 4 stages;
- ✓ Hysteresis for shutting down forced cooling stages when load decreases.

2.2.3 FEXC - Daily cooling activation

The Daily Cooling Activation function prevents fans and/or pumps from remaining inactive for extended periods in transformers operating under low load or during periods of low ambient temperature. This prevents shaft blockage due to dirt accumulation or grease drying. The cooling equipment will be activated daily, according to the equipment's internal clock and depending on the user's selections:

- ✓ Time and minute when the ventilators start operating;
- ✓ Total daily operating time of the ventilators, from 0 to 999 minutes;

The Daily Cooling Activation function can also be used for pre-cooling in transformers subject to cyclic loading, by scheduling the cooling start for a time prior to the daily peak load, with the desired lead time.

2.2.4 OLTD - OLTC temperature differential

On-load tap changers are a major source of transformer failures, and measuring the temperature difference between the transformer oil and the tap changer oil can indicate thermal faults in this equipment before they reach a severity level that could cause more significant problems. Since this temperature difference is subject to external variables, monitoring is performed in two distinct modes to increase diagnostic efficiency and avoid false alarms:

- ✓ Instantaneous differential monitoring - Provides fast-response alarms in case of high-intensity faults, even if of short duration;
- ✓ Differential monitoring with filtering - Provides alarms sensitive to permanent faults, even those of low intensity, with a longer detection time.



In three-phase transformers with three single-phase tap changers in individual compartments, the three temperature differentials are calculated relative to the transformer oil temperature.

2.2.5 MMEM - Mass memory (default)

Non-volatile memory for storing temperature measurements and alarm occurrences. The user selects which variable groups they wish to store, and a memory write operation can be initiated by:

- ✓ Time interval between recordings selected by the user;
- ✓ Variation in any of the temperatures greater than the deadband value selected by the user, in °C;
- ✓ Change of state of any of the output relays (cooling control, alarms, shutdowns or self-diagnosis).



2.3 Basic operating philosophy

Based on readings of the insulating oil temperature and the transformer load current, the Temperature Monitor calculates (thermal image) the winding temperature using an algorithm implemented in its firmware. This algorithm incorporates transformer data programmed by the user, adapting the model to their characteristics.

Oil temperature is measured directly using Pt100 type resistive sensors. Transformer load current is measured via the secondary winding of one or more current transformers (CTs) connected directly to TM1 and TM2, or via external window CTs with a sectionable core (optional supply).

The TM1 and TM2 Temperature Monitors can control up to 4 forced cooling groups, in manual or automatic mode. In automatic mode, the control of the forced cooling groups is always based on the highest measured value among the oil and winding temperatures 1, 2, and 3. If the optional pre-cooling function is available, forced cooling can also be controlled based on the percentage loads of the windings, considering the highest measured load. The pre-cooling function causes the cooling groups to be activated before the transformer reaches the temperature levels pre-established in the automatic control settings, due to the thermal inertia of the oil and windings, thus reducing the average operating temperature of the transformer.

2.3.1 On-load tap changer temperature differential (optional)

The tap changer is one of the main sources of failure in power transformers, primarily due to the presence of moving parts that conduct and interrupt high currents while subjected to high electrical potentials.

Some of the most common failure modes in tap changers are related to deteriorated contacts or mechanical misfits that cause an increase in contact resistance and lead to significant heating, which tends to further increase this resistance, in a cascading effect that leads to complete failure, generally with a high degree of severity.

Under normal operating conditions, the tap changer is a relatively insignificant heat source compared to the heat generated by transformer losses, so the oil temperature in the tap changer tank is mainly influenced by the transformer oil temperature. The graph in the next figure, based on actual measurements, illustrates this situation. It shows, in addition to the individual temperatures of the transformer and the tap changer, the temperature difference between the tap changer and the transformer, which is monitored to detect faults such as those mentioned above.

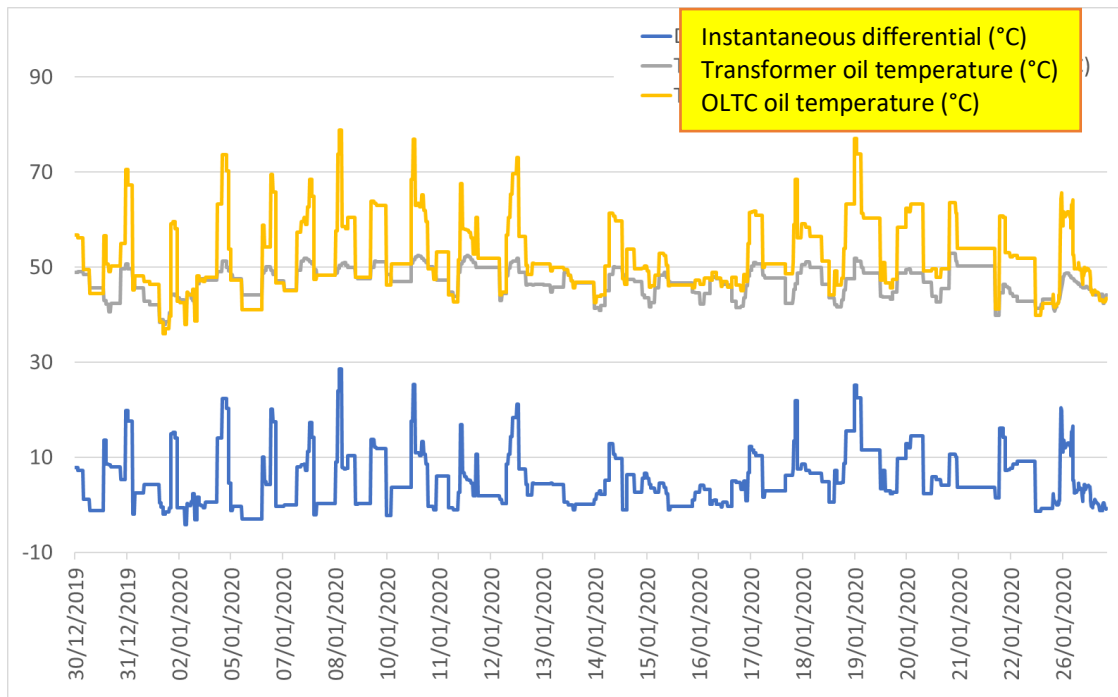

Figure 2 - Temperature measurements of the OLTC, transformer, and temperature differential

Since the **temperature differential** is subject to the influence of external variables, such as forced cooling activation, rapid changes in atmospheric conditions, and others, monitoring is carried out in two distinct modes, illustrated in the next figure, in order to increase the efficiency of the diagnosis and avoid false alarms:

- **Instantaneous differential monitoring** - Monitoring the instantaneous temperature differential provides rapid response alarms in case of high-intensity faults, even if of short duration.
- **Filtered differential monitoring** - The filtered temperature differential is obtained by subjecting the instantaneous differential to a low-pass filter with a user-adjustable time constant. Monitoring it allows for the detection of trends in the differential's evolution that indicate small, permanent defects, although with a longer detection time.

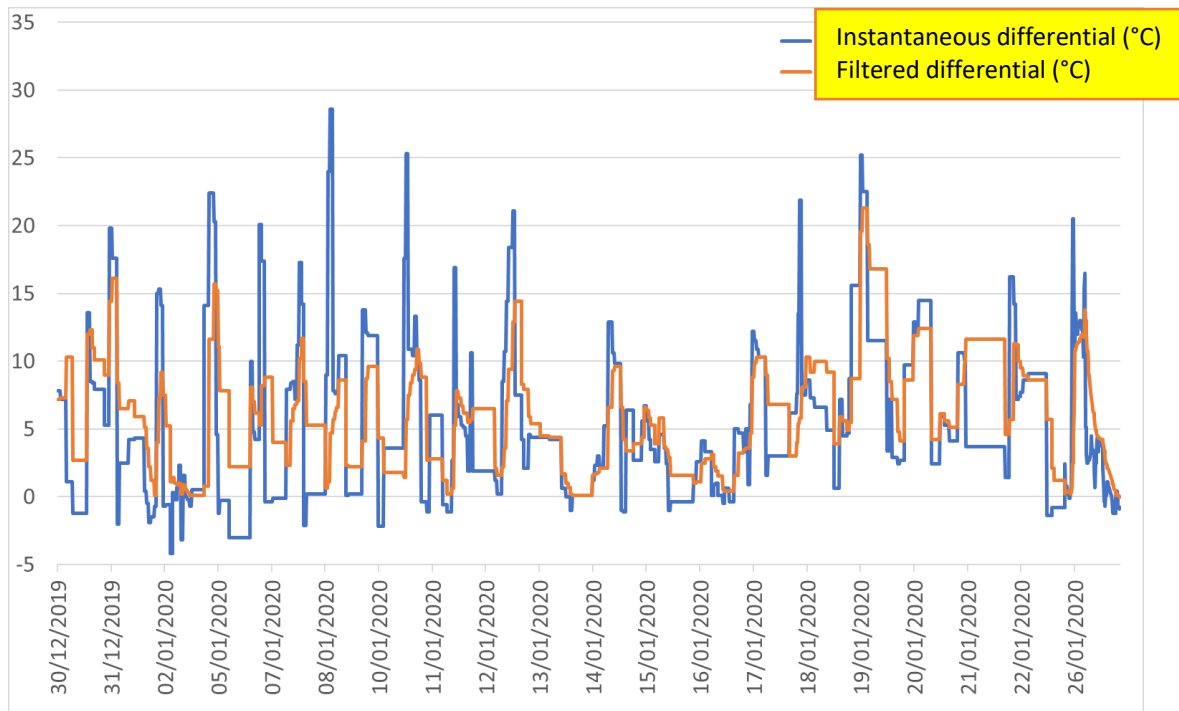

Figure 3 - Instantaneous and filtered temperature differentials

The alarm settings for instantaneous and filtered temperature differentials can be automatically determined by the Temperature Monitor, through a learning period of the OLTC's normal behavior. These alarms can later be manually changed by the user.

The duration of this learning period can be adjusted by the user, typically using a value of one week. During this period, the maximum values reached by the instantaneous and filtered temperature differentials are recorded, and a programmed tolerance margin is added to these maximum values, thus obtaining the instantaneous and filtered differential alarm values, respectively.

If the measured values for the instantaneous or filtered temperature differentials exceed their respective alarm values, the Temperature Monitor will signal this via the corresponding LED on its front panel and, if programmed this way, will activate the A1-A2 output contact on TM1 and/or TM2.

Just like the transformer oil temperature, the on-load tap changer oil temperature measurement is performed using a 0°C Pt100Ω sensor, which is connected to one of the available inputs on the TM1 or TM2. The TM1 Temperature Monitor has 2 available inputs for Pt100 sensors; at least one of them must be used for transformer oil temperature, and the other can be used for redundant measurement of transformer oil or tap changer temperature, ambient temperature, or other temperatures. The TM2 has 2 additional free inputs for measuring tap changer temperature, ambient temperature, or other temperatures.

3 Design and installation

3.1 System topology

Basically, the Temperature Monitoring system consists of:

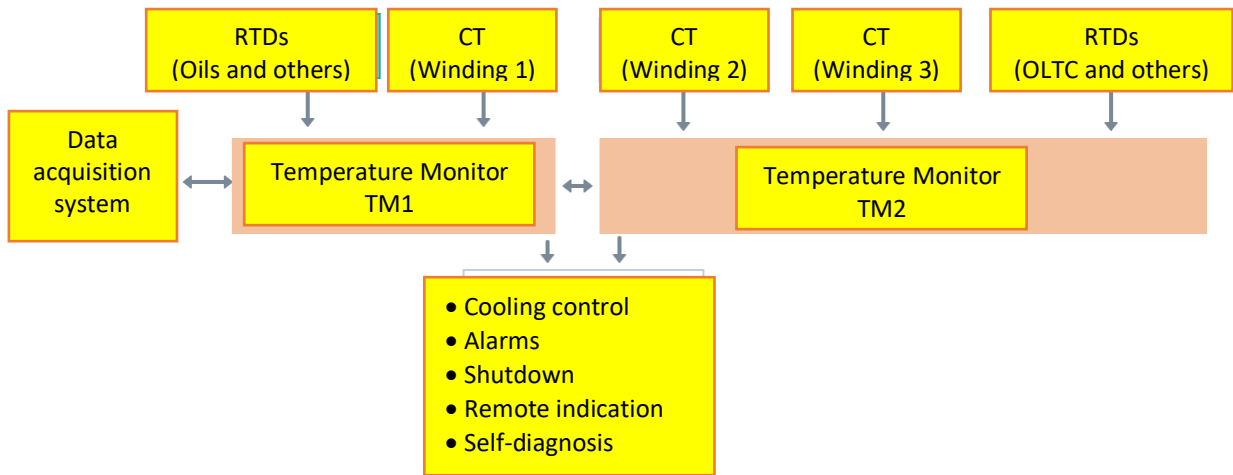

Figure 4 - Block diagram

The items needed for the system are:

- Temperature Monitor TM1
- RTD Sensors (quantity and type as per desired configuration)
- Temperature Monitor TM2 (only if temperature measurement of more than one winding or more than 2 RTD sensors is required)
- Current Transformers (transformer bushing CTs)
- 2-wire shielded twisted-pair cable for serial communication
- 3 or 4-wire shielded cable (depending on the connection option adopted) for connecting the RTD(s)
- Outdoor installation enclosure (optional)
- External window CTs with sectionalizable core (clip-on), optional use.



3.2 Electrical installation

The TM1/TM2 is a versatile piece of equipment that can meet a variety of different types of applications.

Therefore, its installation requires a higher level of study and care than equipment dedicated exclusively to a single application or task.

The TM1/TM2 features different electrical installation configurations. These configurations are determined by the application's use of the available features and options.



Study and understand the application in which you intend to use the TM1/TM2. Familiarize yourself with the functional, electrical, and configuration characteristics of the TM1/TM2. This way you will be able to take full advantage of the equipment and minimize risks to your safety.



This equipment operates at dangerous voltage levels, which could cause death or serious injury to the operator or maintenance personnel.

Some special precautions must be taken for the design and installation of TM1 and TM2, as described below.



A circuit breaker should be used immediately before the power input (Universal power supply - 38 ~ 265 Vac/Vdc, <8 W, 50/60 Hz), which corresponds to pins 14 and 15 of TM1/TM2.

The circuit breaker must have the number of poles corresponding to the number of phases used in the power supply, with the poles interrupting only the phases, and never the neutral or ground. It must also provide thermal and electrical protection to the conductors supplying the equipment and must be located near the equipment and easily operable by the operator.

Additionally, it must have indelible identification showing that it is the electrical disconnection device for TM1/TM2.



The following circuit breaker specification is recommended when used exclusively for TM1/TM2:

- AC/DC Power Supply, Phase-Neutral: Single-pole circuit breaker, $1 A \leq I_n \leq 2 A$, curve B or C, standards NBR/IEC 60947-2, NBR/IEC 60898 or IEEE 1015-2006;
- AC/DC Power Supply, Phase-to-Phase: Bipolar circuit breaker, $1 A \leq I_n \leq 2 A$, curve B or C, standards NBR/IEC 60947-2, NBR/IEC 60898 or IEEE 1015-2006.



The minimum insulation for circuits connected to TM1/TM2 is 300 Vrms for auxiliary equipment and transducers, such as Pt-100 transistors, clip-on CTs powered by TM1/TM2, and up to 50 Vrms for self-powered equipment.

The minimum insulation is 1.7 kV rms for equipment powered up to 300 Vrms, according to IEC EN 61010-1.

These values relate to the intrinsic insulation of devices connected to TM1/TM2. Cases where this value does not apply to equipment or devices connected to TM1/TM2 will be explicitly stated in this manual.

The standard schematic diagram of the TM1/TM2 connections shows all the possible connections they provide, identifying them as shown in the following figure.

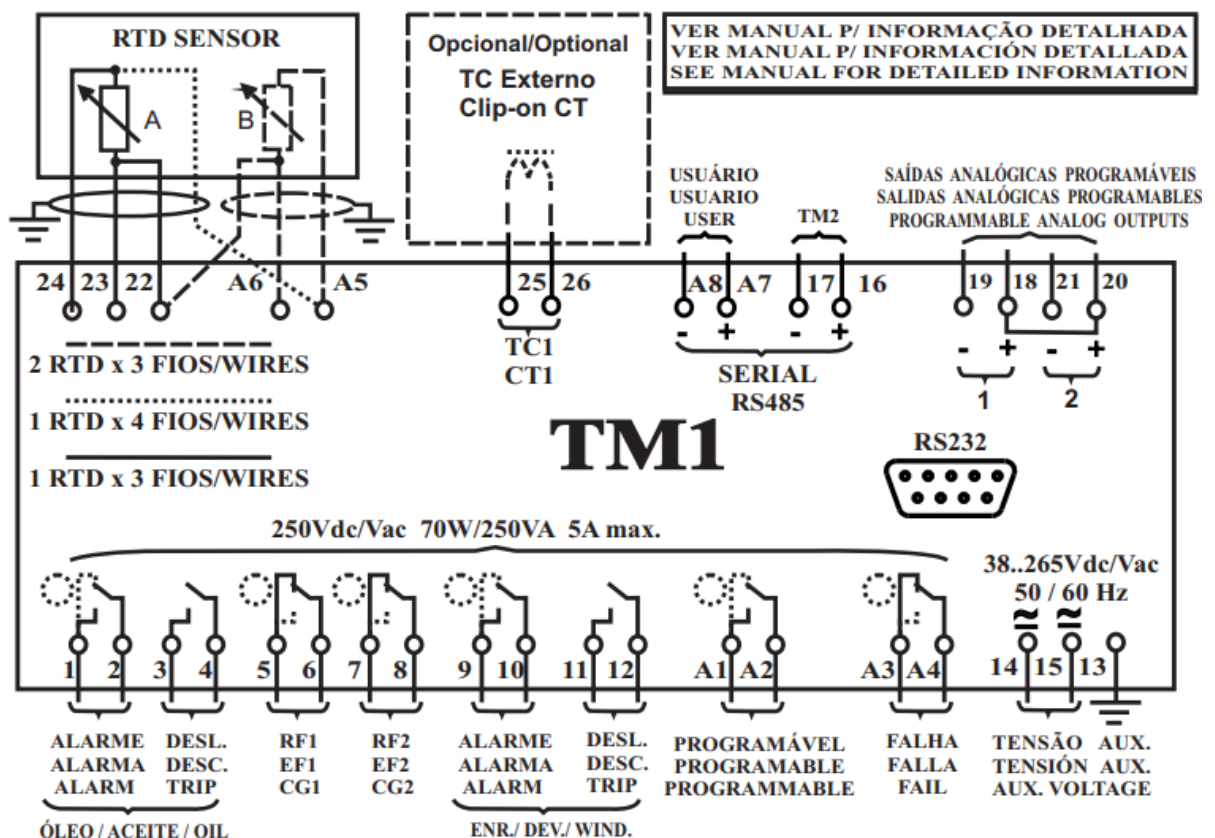

Figure 5 - TM1 wiring diagram

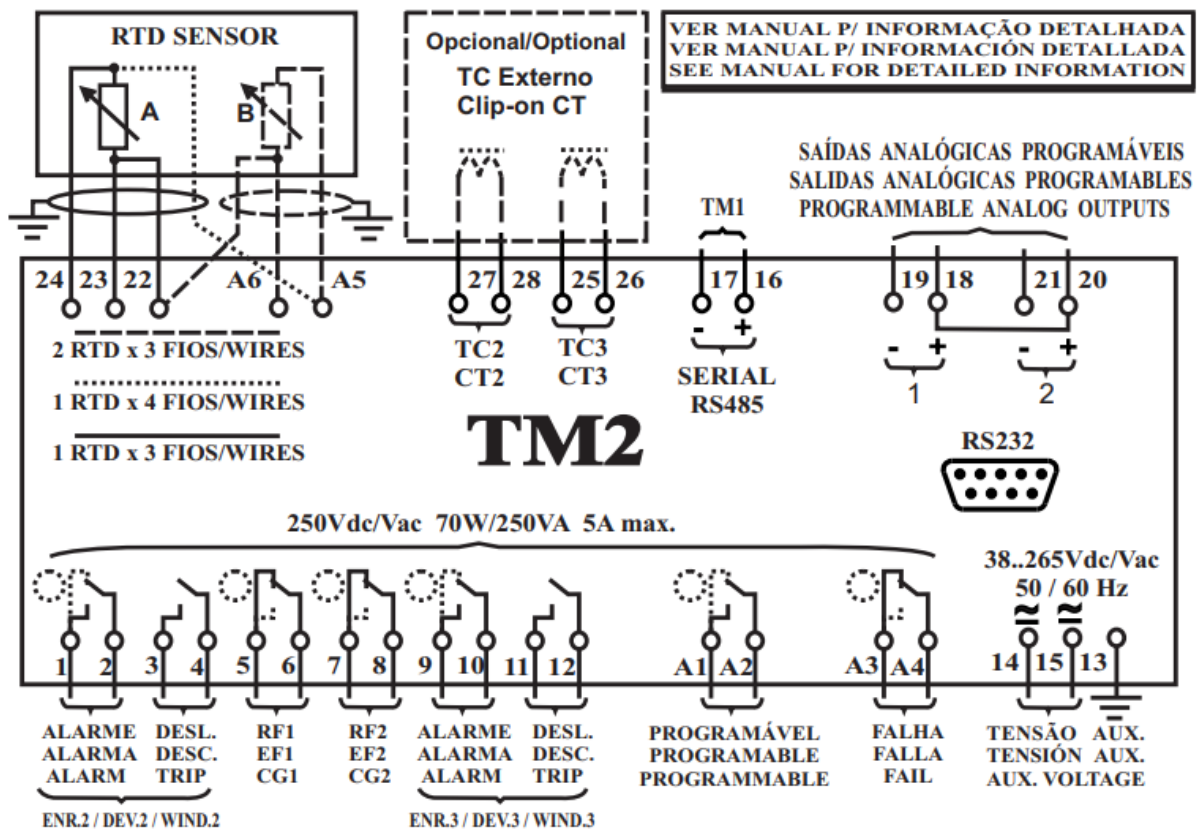

Figure 6 - TM2 wiring diagram

3.2.1 Input and output terminals

The following inputs and outputs are available on the TM1 and TM2 Temperature Monitors:

Table 2 - TM1/TM2 input terminals

INPUTS	TERMINALS	
	TM1	TM2
Auxiliary power supply and ground: Input for universal power supply (38 ~ 265 Vac/Vdc, <8 W, 50/60 Hz).	13 - ground 14 - dc/ac 15 - dc/ac	13 - ground 14 - dc/ac 15 - dc/ac
Input for RTD on TM1: This input allows the connection of RTD sensors in five configurations: <ul style="list-style-type: none"> a) Two redundant three-wire RTDs for oil temperature measurement; b) 1 four-wire RTD for oil temperature measurement; c) 1 three-wire RTD for measuring oil temperature at input A; d) 1 three-wire RTD for measuring oil temperature at input B; 	22, 23, 24, A5 and A6	



<p>e) 1 three-wire RTD for measuring oil temperature at input A and one three-wire RTD for measuring another temperature (e.g., ambient or OLTC) at input B.</p>		
<p>Input for RTD on TM2: This input allows the measurement of additional temperatures, for example, ambient, OLTC or others, in four configurations (see connection option diagrams):</p> <p>a) 1 four-wire RTD; b) 1 three-wire RTD on input A; c) 1 three-wire RTD on input B; d) 2 three-wire RTDs, one on input A and one on input B.</p>	<p>-----</p>	<p>22, 23, 24, A5 and A6 (see wiring diagram)</p>
<p>RS-485 port on TM2: Connection to the complementary TM2 Temperature Monitor via shielded twisted pair cable.</p> <p>When using the DNP3 protocol option with the IRIG-B function, which synchronizes the device's clock via GPS, this port is used, thus preventing the use of TM2.</p>	<p>16 (+) 17 (-)</p>	<p>-----</p>
<p>RS-485 port on TM1: Connection to the TM1 Temperature Monitor via shielded twisted pair cable.</p>	<p>-----</p>	<p>16 (+) 17 (-)</p>
<p>RS-485 / RS-232 port - Scada: Connection to the data acquisition system, Modbus protocol (standard) or DNP3 (optional). The selection of the RS-485 or RS-232 communication standard is made during equipment parameterization.</p>	<p>A7 (+) A8 (-) or DB9 connector (rear panel)</p>	<p>-----</p>
<p>Input for CT: Input for direct measurement of the secondary of the bushing CT for thermal imaging or for connection of a clip-on window CT. Measurement range selected via the device software.</p>	<p>25 and 26 (TC 1)</p>	<p>25 and 26 (TC 3) 27 and 28 (TC 2)</p>



Table 3 - TM1/TM2 output terminals

OUTPUTS	TERMINALS	
	TM1	TM2
<p>Current loop outputs: Two outputs with common positive for remote indication of measured temperatures, programmable by the user. Output pattern selected in the parameterization (0...1, 0...5, 0...10, 0...20 or 4...20 mA).</p>	18(+) Common 19(-) 20(+) Common 21(-)	18(+) Common 19(-) 20(+) Common 21(-)
<p>Alarm relay: Two independent, potential-free (NO) contacts signal alarms due to high transformer temperature. Upon request, these contacts can be supplied normally closed (NC).</p>	1 and 2 - Alarm due to oil temperature 9 and 10 - Alarm due to winding 1 temperature	1 and 2 - Alarm due to winding 2 temperature 9 and 10 - Alarm due to winding 3 temperature
<p>Shutdown relay: Two independent, potential-free (NO) contacts for transformer protection or level 2 alarm. These contacts can be programmed to operate with a time delay of up to 20 minutes.</p>	3 and 4 - Shutdown due to oil temperature 11 and 12 - Shutdown due to winding 1 temperature	3 and 4 - Shutdown due to winding 2 temperature 11 and 12 - Shutdown due to winding 3 temperature
<p>Control relays for forced cooling: Two independent (NC) contacts on each Temperature Monitor, potential-free, for controlling up to 4 forced cooling groups (using TM1 and TM2). When the Temperature Monitors are powered on, these contacts change state, returning to the rest position to activate the cooling. Upon request, these can be supplied normally open (NA).</p>	5 and 6 - Contacts for GR1 activation 7 and 8 - Contacts for GR2 activation	5 and 6 - Contacts for GR3 or GR1 activation 7 and 8 - Contacts for GR4 or GR2 activation (depend on the parameterization)
<p>Self-diagnosis relay: Potential-free (NC) contact, signals power failure, internal fault or system fault. When the Temperature Monitor is powered on, this contact changes state, returning to the rest position in the event of a fault. Upon request, this contact can be supplied normally open (NO).</p>	A3 and A4	A3 and A4
<p>Relay for signaling shutdown or OLTC temperature differential: Programmable potential-free (NO) contact to signal alarms due to OLTC temperature differential or transformer shutdown – acts instantly upon reaching the shutdown temperature, signaling that one or more shutdown contacts are activated or in the timing process to activate. Upon request, this contact can be supplied normally closed (NC).</p>	A1 and A2	A1 and A2



3.2.2 RTD temperature sensors

The various RTD temperature sensors (oil, ambient, on-load tap changer, or others) must be connected to Temperature Monitors TM1 and TM2 using shielded cables, without interrupting the shields, which should only be grounded at the end connected to the Temperature Monitor, as close as possible to it. If intermediate terminals are needed to interconnect the RTD sensors, also pass the cable shield through the terminal, avoiding interruption of the shield. The unshielded cable section due to the splice should be as short as possible.



The maximum resistance for each of the wires used in the TM1/TM2 interconnection cable with the Pt100 sensors is 3 Ω. That is, 6 Ω for the round trip from the Pt100 sensor to the TM1/TM2.



Considering the maximum permissible resistance in the connection between the Pt100 and the TM1/TM2, for a copper cable with a gauge of 1.5 mm², the Pt100 can be installed at a maximum distance of 265 m from the TM1/TM2. Other values are possible with correct cable sizing. If you need support for cable sizing, please contact Treotech's application engineering department.

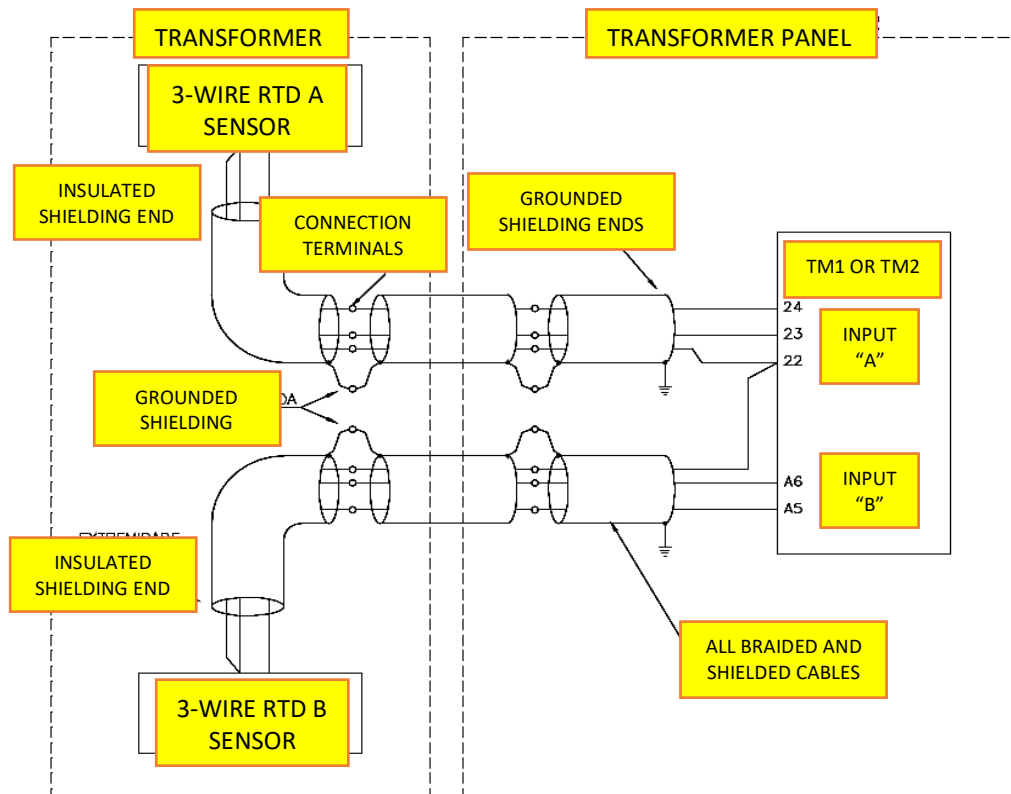

Figure 7 - Shielding connection for the interconnection between RTD sensors and TM1/TM2



3.2.3 RS-485 serial communications

The serial communication (RS-485) between the TM1 and TM2 Temperature Monitors must be interconnected using a shielded twisted-pair cable, maintaining the shield uninterrupted until its termination at the specific input of the devices, grounding only one end. The same care must be taken when connecting the RS-485 serial communication of the TM1 Temperature Monitor to a data acquisition system, remembering that the maximum distance allowed for this type of serial communication is 1200 meters.

If intermediate terminals are needed for interconnecting the RS-485 serial communication and/or RTD sensors, also route the cable shield through a terminal to avoid interrupting it. The unshielded cable section due to the splice should be as short as possible.

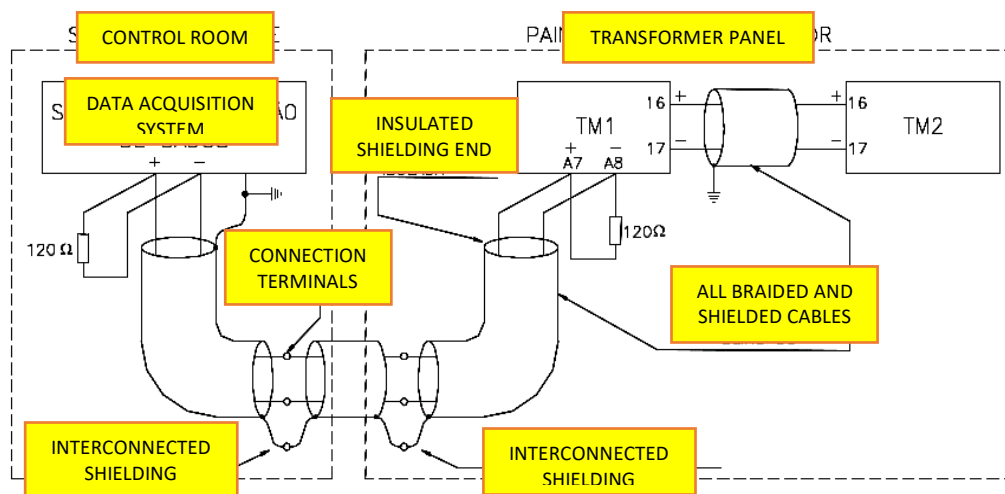

Figure 8 - TM1/TM2 input and output terminals in their default configuration

3.2.4 Analog outputs

The analog signaling circuit (mA output) must be interconnected using a shielded twisted-pair cable, maintaining the shield uninterrupted until its termination at the specific input of the devices, grounding only at the end closest to the equipment.

If intermediate terminals are needed to interconnect the current outputs, also pass the cable shield through a terminal to avoid interrupting it. The unshielded cable section due to the splice should be as short as possible.



The two outputs corresponding to pins 18 and 20 are interconnected, resulting in a common positive voltage.



Using unsuitable cables for RS-485 communication and mA output may compromise the performance of the TM1/TM2.

Always use the recommended cables.

3.2.5 Current transformers

The connections for the current transformers must be made according to the model of the Temperature Monitor purchased:

- For direct connection of secondary windings (0...10 A) from thermal imaging CTs to the Temperature Monitors;
- Circuit Load at 10A (Maximum Power Consumption): 690.49 mW
- Impedance at 10A: 6.904 mΩ
- Voltage at the CT at 10A: 69.04 mV
- For connection with the use of external split-core CTs.

In both cases, due care must be taken to avoid opening the secondary windings of the thermal imaging CTs, verifying that the transformer is de-energized and/or that the secondary windings are short-circuited and grounded during system installation or maintenance.

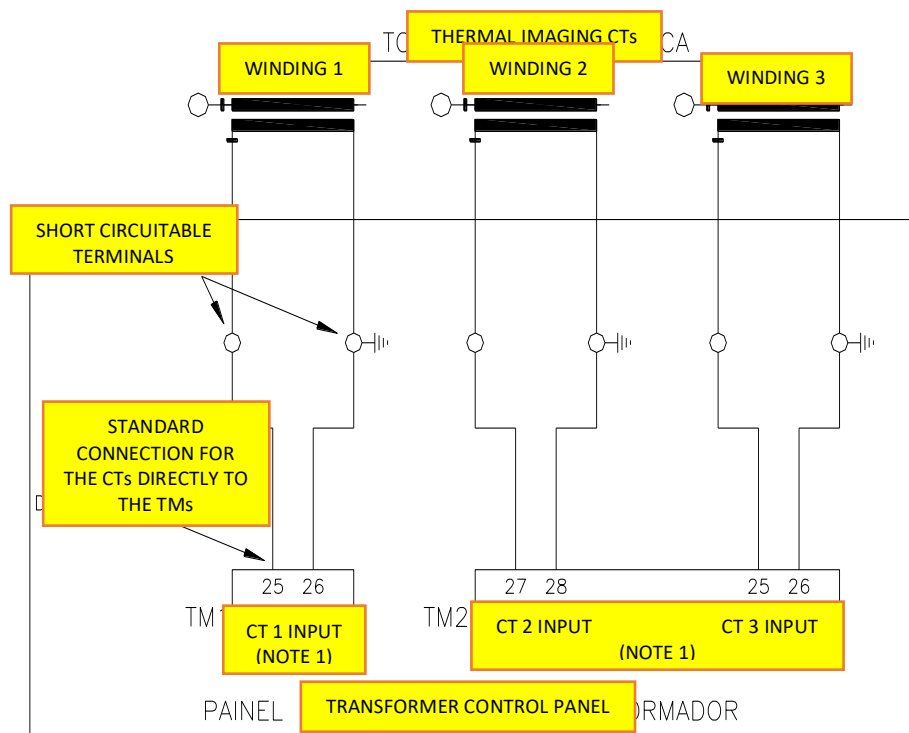

Figure 9 - Detail of correctly connecting transformers directly to the Temperature Monitors

Note 1: TM1 and TM2 must be specified in the purchase order for direct CT connection.

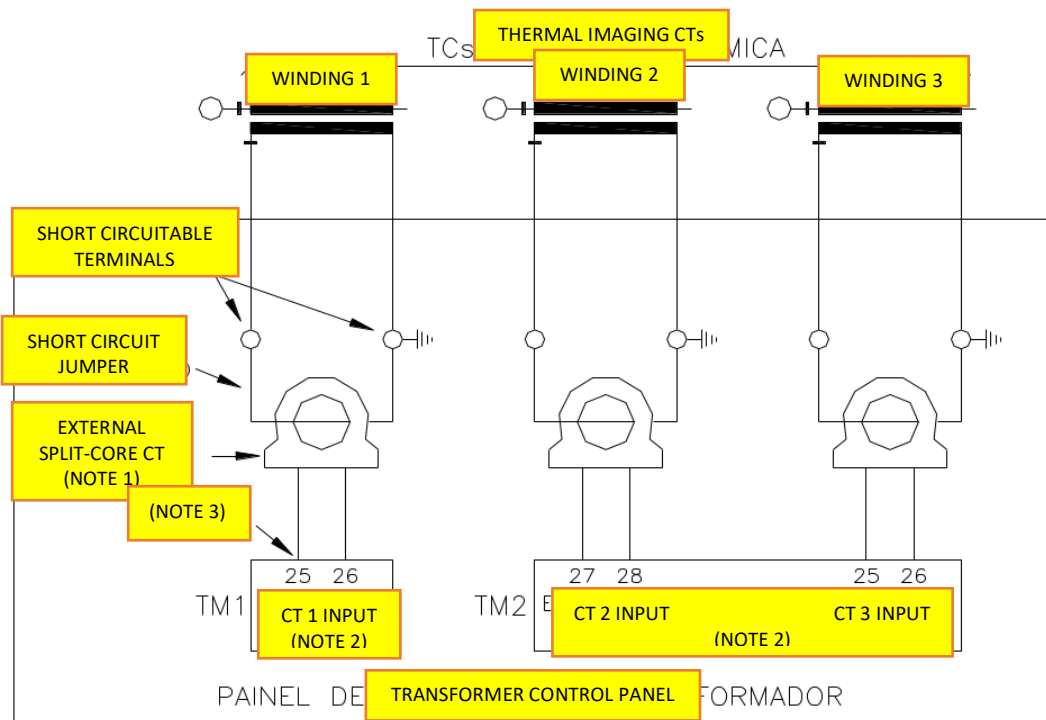

Figure 10 - Detail of the connection of current transformers to Temperature Monitors for external sectionable core CTs

Note 1: Optional component supplied by Treetech.

Note 2: TM1 and TM2 must be specified in the purchase order for use with an external split-core CT.

Note 3: Do not connect thermal imaging CTs directly to a temperature monitor designed for use with external CTs. Risk of personal injury or equipment damage due to opening the CT secondary.

3.2.6 Forced cooling control

Each of the TM1 and TM2 Temperature Monitors has two independent, potential-free NC contacts for controlling 1 to 4 forced cooling groups, as programmed by the user. Groups 1 and 2 are controlled by contacts 5-6 and 7-8 of TM1, and groups 3 and 4 by contacts 5-6 and 7-8 of TM2, respectively. When the Temperature Monitors are powered on, these contacts change state, returning to the rest position to activate the cooling. Normally open (NO) contacts can be supplied upon request. The forced cooling operation programming is divided into 4 cooling stages. Each stage has its operating temperature programmed (also the load percentage for activation, if the Pre-cooling option is available) and the cooling groups that are registered and available for use by that stage. The following table exemplifies the programming of the cooling stages:

Table 4 - Programming the cooling stages

Cooling stage	Activation temperature	Cooling groups			
		Group 1	Group 2	Group 3	Group 4
ER1	RF1 = 60 °C	YES	YES	NO	NO
ER2	RF2 = 65 °C	YES	YES	NO	NO
ER3	RF3 = 70 °C	NO	NO	YES	YES
ER4	RF4 = 75 °C	NO	NO	YES	YES

When the operating temperature of a given stage is reached, it will activate only one of its registered cooling groups (the groups registered in the stage are those selected as "YES"). The choice of which group to activate will be based on the operating times of the groups: the one



with the shortest operating time will be chosen. Similarly, when the temperature drops below the stage's deactivation value, it will deactivate only one of the cooling groups that are activated and registered in the same stage. The choice of which group to deactivate will be based on the operating times of the groups: the one with the longest operating time will be chosen. In this way, the cooling groups will tend to have equivalent operating times, thus avoiding excessive wear on one group at the expense of others.

Below are some examples of different possible applications for the TM1/TM2 forced cooling command, with their respective configurations.

3.2.6.1 Example 1 - Four identical cooling groups with staggered activation temperatures

In this example, since all 4 groups are identical, it is desirable to alternate the activation of the groups as the measured temperature rises. Otherwise, if the activation order of the groups were fixed, the groups activated at lower temperatures could experience significantly greater wear than the others. To achieve complete alternation between the 4 groups, all of them are enrolled (selected as "YES") in all cooling stages.

To illustrate this concept, let's say that groups 1 through 4 have the following accumulated operating times: 1034, 1056, 993, and 1042 hours, respectively. When the winding temperature rises and reaches 60 °C, the group with the shortest operating time among those enrolled in stage 1 (groups 1, 2, 3, and 4) will be activated, in this case group 3. When the temperature reaches 65 °C, the group with the shortest operating time among those enrolled in stage 2 that are not yet in operation will be activated, in this case group 1. Similarly, at 70 °C group 4 will be activated and at 75 °C group 2. Continuing with the example above, let's say that after some time operating at a temperature above 75 °C, the accumulated operating times for groups 1 to 4 are: 1042, 1060, 1003, and 1048 hours, respectively. Assuming a hysteresis adjustment of 1°C, when the winding temperature drops below 74°C, the group with the longest operating time among those enrolled in stage 4 and currently in operation will be switched off (in this case, group 2). When the temperature is below 69°C, the group with the longest operating time among those enrolled in stage 3 and still in operation will be switched off (in this case, group 4). Similarly, below 64°C, group 1 will be switched off, and below 59°C, group 3 will be switched off.

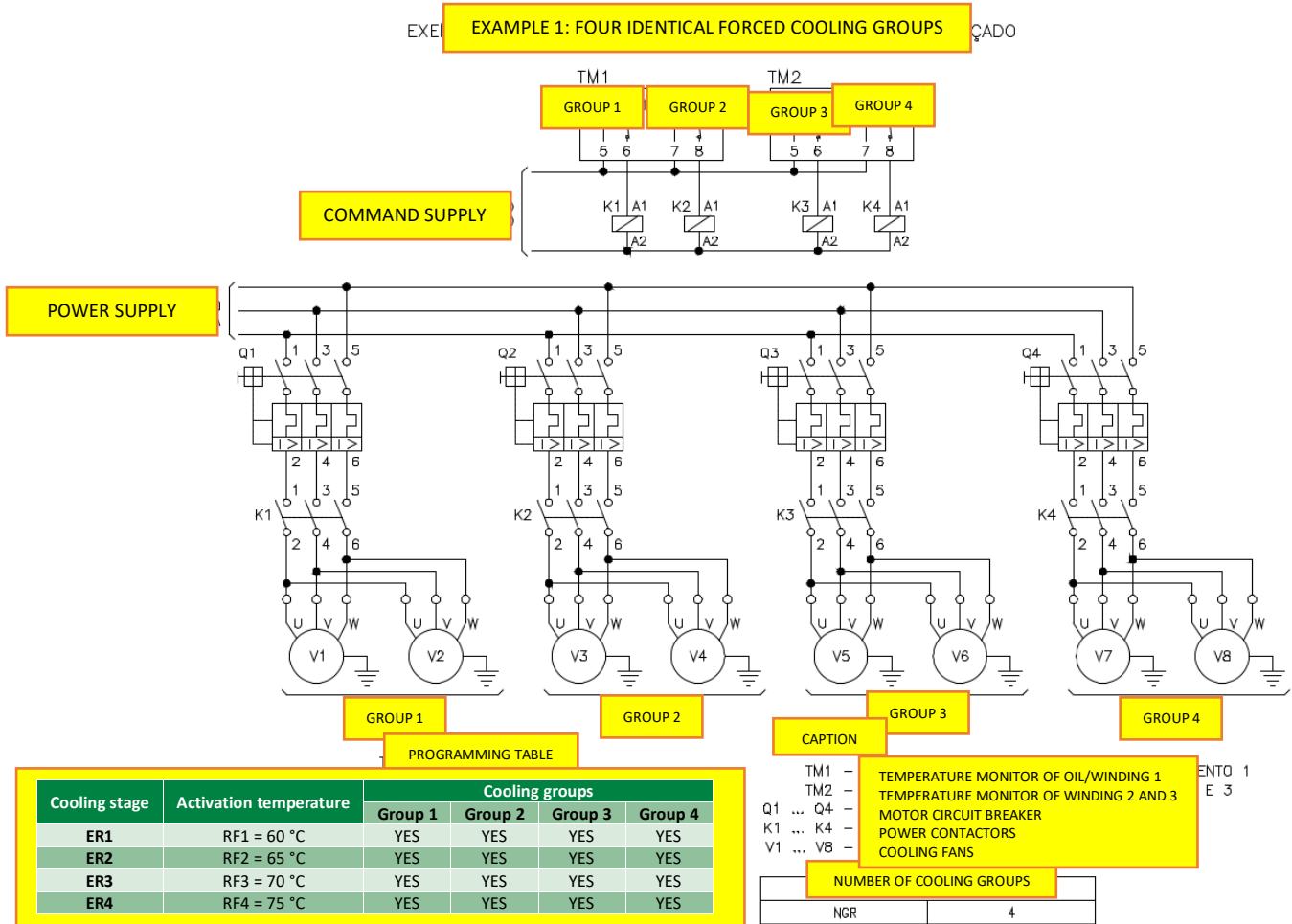

Figure 11 - Control system for 4 identical forced cooling groups, with alternating operation of the groups

3.2.6.2 Example 2 - A cooling group with pumps and three identical cooling groups with fans with staggered activation temperatures

In this example, since group 1 is different from groups 2 to 4, which are identical to each other, there should be no alternation between group 1 and the others, and it is desirable that there be alternation between groups 2, 3, and 4. To achieve this, only group 1 is enrolled (selected as "YES") in cooling stage 1, and to obtain alternation between groups 2, 3, and 4, they are enrolled in cooling stages 2, 3, and 4.

To illustrate this concept, let's say that groups 1 to 4 have the following accumulated operating times: 2011, 1245, 1191, and 1187 hours, respectively. When the winding temperature rises and reaches 60 °C, group 1, which is the only one enrolled in stage 1, will be automatically activated. When the temperature reaches 65 °C, the group with the shortest operating time among those enrolled in stage 2 (groups 2, 3, and 4) will be activated, in this case, group 4. When the temperature reaches 70 °C, the group with the shortest operating time among those enrolled in stage 3 that are not yet in operation will be activated, in this case, group 3. Similarly, at 75 °C, group 2 will be activated.

Continuing with the example above, let's say that after some time operating at a temperature above 75 °C, the accumulated operating times for groups 1 to 4 are: 2022, 1249, 1196, and

1197 hours, respectively. Assuming a hysteresis adjustment of 1 °C, when the winding temperature is below 74 °C, the group with the longest operating time among those enrolled in stage 4 and currently operating will be switched off; this is group 2. When the temperature is below 69 °C, the group with the longest operating time among those enrolled in stage 3 and still operating will be switched off; this is group 4. Similarly, below 64 °C, group 3 will be switched off, and below 59 °C, group 1, which is the only one enrolled in stage 1, will be switched off.

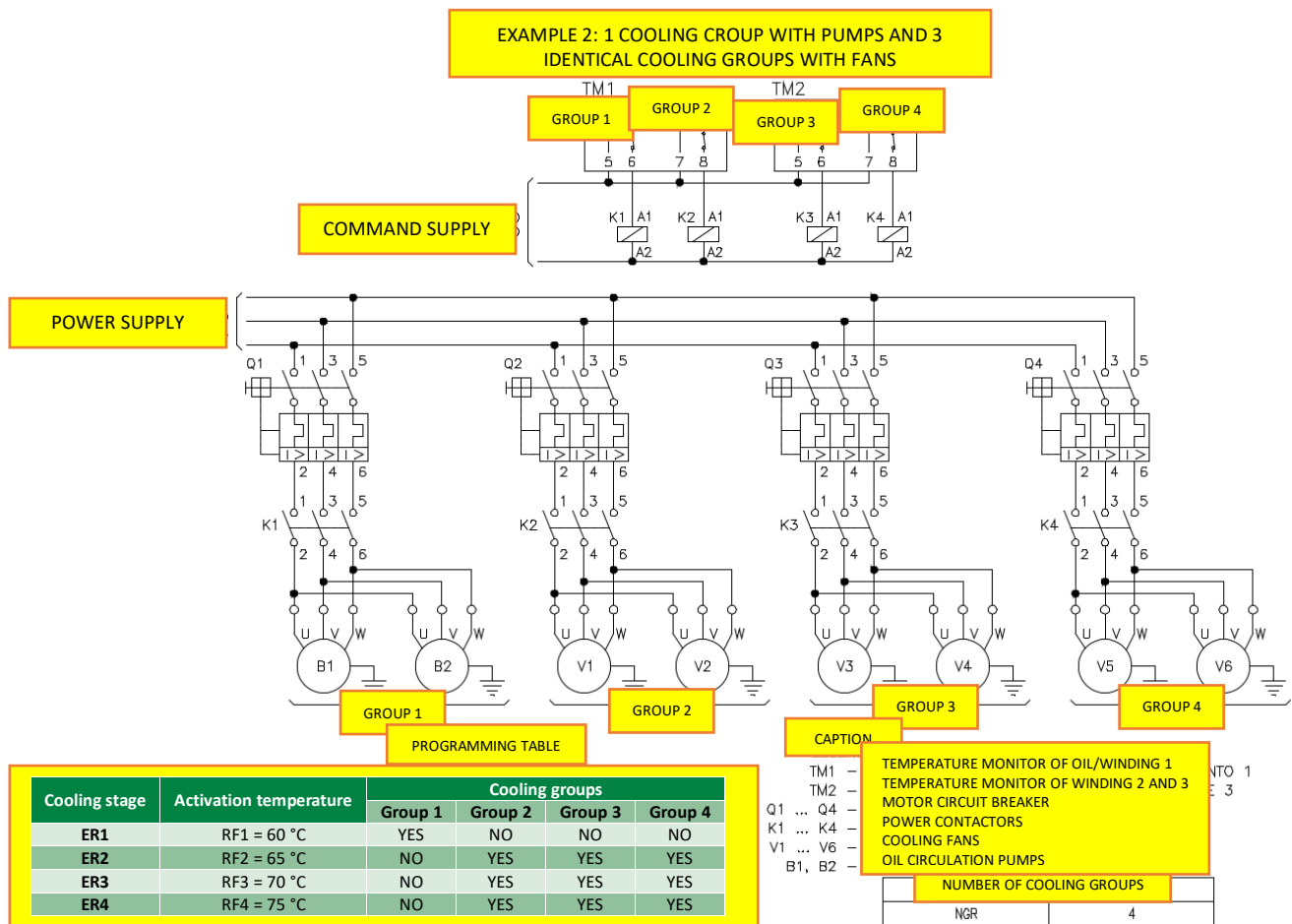

Figure 12 - Control system for 1 forced cooling group with pumps and 3 identical groups with alternating operation of the fan groups

3.2.6.3 Example 3 - Two identical cooling groups with pumps and two identical groups with fans, with staggered activation temperatures

In this example, groups 1 and 2 are identical to each other and different from groups 3 and 4, which are in turn identical to each other. Therefore, there should be no alternation between groups 1 and 2 and groups 3 and 4, although it is desirable to have an alternation between groups 1 and 2 and another independent alternation between groups 3 and 4. To achieve this, only groups 1 and 2 are enrolled (selected as “YES”) in cooling stages 1 and 2, and groups 3 and 4 are enrolled in cooling stages 3 and 4.

To illustrate this concept, let's say that groups 1 to 4 have the following accumulated operating times: 1803, 1798, 1501, and 1509 hours, respectively. When the winding temperature increases and reaches 60 °C, the group with the shortest operating time among those enrolled in stage 1 (groups 1 and 2) will be activated, in this case group 2. When the temperature reaches 65 °C, the group with the shortest operating time among those enrolled in stage 2 that are not yet in operation will be activated, in this case group 1. When the temperature reaches 70 °C, the group with the shortest operating time among those enrolled in stage 3 that are not yet in operation will be activated, in this case group 3. Similarly, at 75 °C, group 4 will be activated.

Continuing with the example above, let's say that after some time operating at a temperature above 75 °C, the accumulated operating times for groups 1 to 4 are: 1809, 1810, 1505, and 1512 hours, respectively. Assuming a hysteresis adjustment of 1 °C, when the winding temperature drops below 74 °C, the group with the longest operating time among those enrolled in stage 4 that are in operation will be switched off; in this case, group 4. When the temperature is below 69 °C, the group with the longest operating time among those enrolled in stage 3 that are still in operation will be switched off; in this case, group 3. Similarly, below 64 °C, group 1 will be switched off, and below 59 °C, group 2 will be switched off.

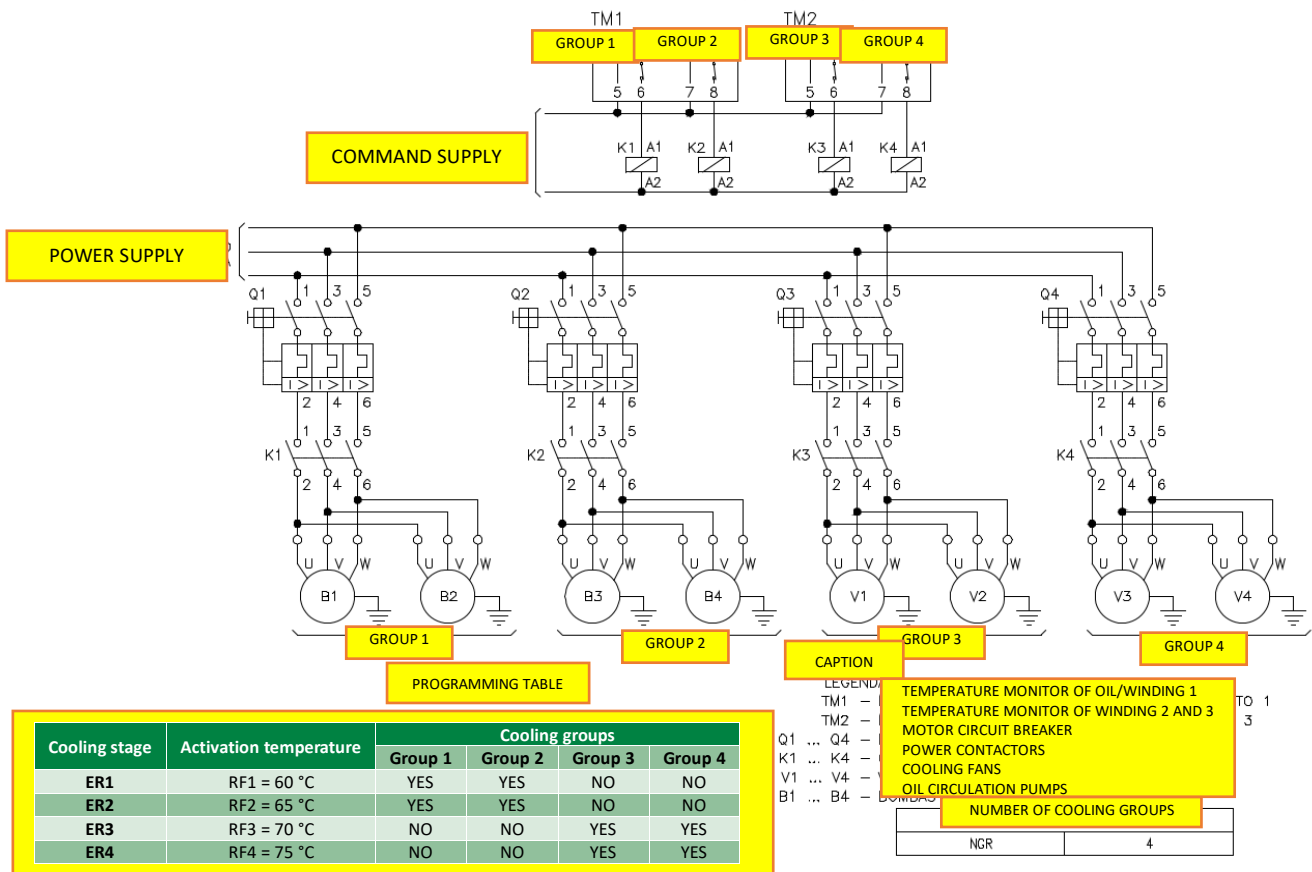

Figure 13 - Control system for 2 identical forced cooling groups with pumps and 2 identical groups with fans, with independent alternation of operation between pump groups and fan groups



3.2.6.4 Example 4 - Four identical cooling groups, with timing at engine start-up

In this example, the cooling stages should be activated at only two different levels, 60°C and 65°C. However, in order to reduce the current peak due to motor start-up, the fans were divided into four equal cooling groups, so that when either temperature level is reached, one group is activated immediately, and another is activated after a 10-second delay.

To allow for alternating fan activation, cooling stages 1 and 2 are programmed with the same activation temperature, but stage 1 only includes groups 1 and 2 (selected as "YES"), while stage 2 includes groups 3 and 4. Similarly, stages 3 and 4 are programmed with the same activation temperature, stage 3 includes only groups 1 and 2, and stage 4 includes groups 3 and 4.

To illustrate the operation, let's say that groups 1 to 4 have the following accumulated operating times: 500, 503, 500, and 503 hours, respectively. When the winding temperature increases and reaches 60 °C, the group with the shortest operating time among those enrolled in stage 1 (groups 1 and 2) will be activated, in this case group 1, and after a 10-second delay, the group with the shortest operating time among those enrolled in stage 2 (groups 3 and 4) will be activated, in this case group 3. When the temperature reaches 65 °C, the group with the shortest operating time among those enrolled in stage 3 that are not yet in operation will be activated, in this case group 2, and after a 10-second delay, the group with the shortest operating time among those enrolled in stage 4 (groups 3 and 4) that are not yet in operation will be activated, in this case group 4.

Continuing with the example above, let's say that after some time the temperature drops below 59 °C and all cooling groups are switched off, with the accumulated operating times for groups 1 to 4 now being: 509, 508, 509 and 508 hours, respectively. When the winding temperature rises and reaches 60 °C, the group with the shortest operating time among those enrolled in stage 1 (groups 1 and 2), in this case group 2, will be activated, and after a 10-second delay, the group with the shortest operating time among those enrolled in stage 2 (groups 3 and 4), in this case group 4, will be activated. When the temperature reaches 65 °C, the group with the shortest operating time among those enrolled in stage 3 that are not yet in operation will be activated, in this case group 1, and after a 10-second delay, the group with the shortest operating time among those enrolled in stage 4 (groups 3 and 4) that are not yet in operation will be activated, in this case group 3.

EXAMPLE 4: 2 COOLING GROUPS WITH FANS AND TIMED ACTIVATION

Figure 14 - Control system for 4 identical forced cooling groups in 2 temperature stages, with timing at engine start-up and alternation between groups

In transformers with only 2 cooling groups, the TM2 contacts are used to redundantly control groups 1 and 2, and must be connected in parallel with the TM1 contacts.

3.2.6.5 Example 5 - Two identical cooling groups, with redundancy in cooling control

In this example, the cooling stages should be activated at only two different levels, 60 °C and 65 °C. However, since there is no need for timing during motor start-up, only two cooling groups are used, and the TM2 contacts are used to redundantly control groups 1 and 2, and should be connected in parallel with the TM1 contacts.

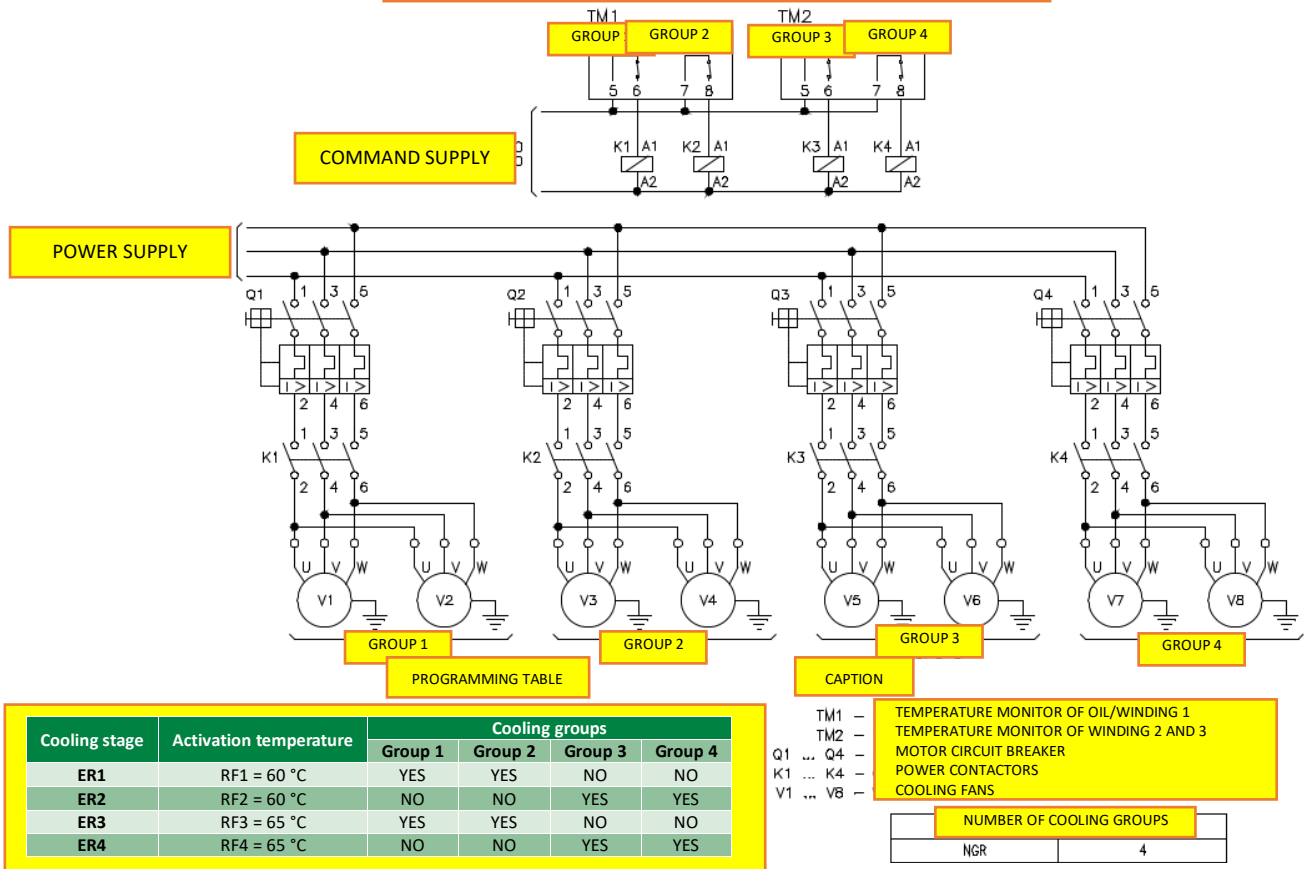
For the activation of the two groups to alternate, both are registered (selected as "YES") in both cooling stages.

To illustrate the operation, let's say that groups 1 and 2 have the following accumulated operating times: 645 and 648 hours, respectively. When the winding temperature increases and reaches 60 °C, the group with the shortest operating time among those enrolled in stage 1 (groups 1 and 2) will be activated, in this case group 1. When the temperature reaches 65 °C, the group with the shortest operating time among those enrolled in stage 2 that are not yet in operation will be activated, in this case group 2.

Continuing with the example above, let's say that after some time the temperature drops below 59 °C and all cooling groups are switched off, with the accumulated operating times for groups 1 and 2 now being 651 and 650 hours, respectively. When the winding temperature rises and reaches 60 °C, the group with the shortest operating time among those enrolled in stage 1 (groups 1 and 2) will be activated, in this case group 2. When the temperature reaches 65 °C, the group with the shortest operating time among those enrolled in stage 2 that are not yet in operation will be activated, in this case group 1.

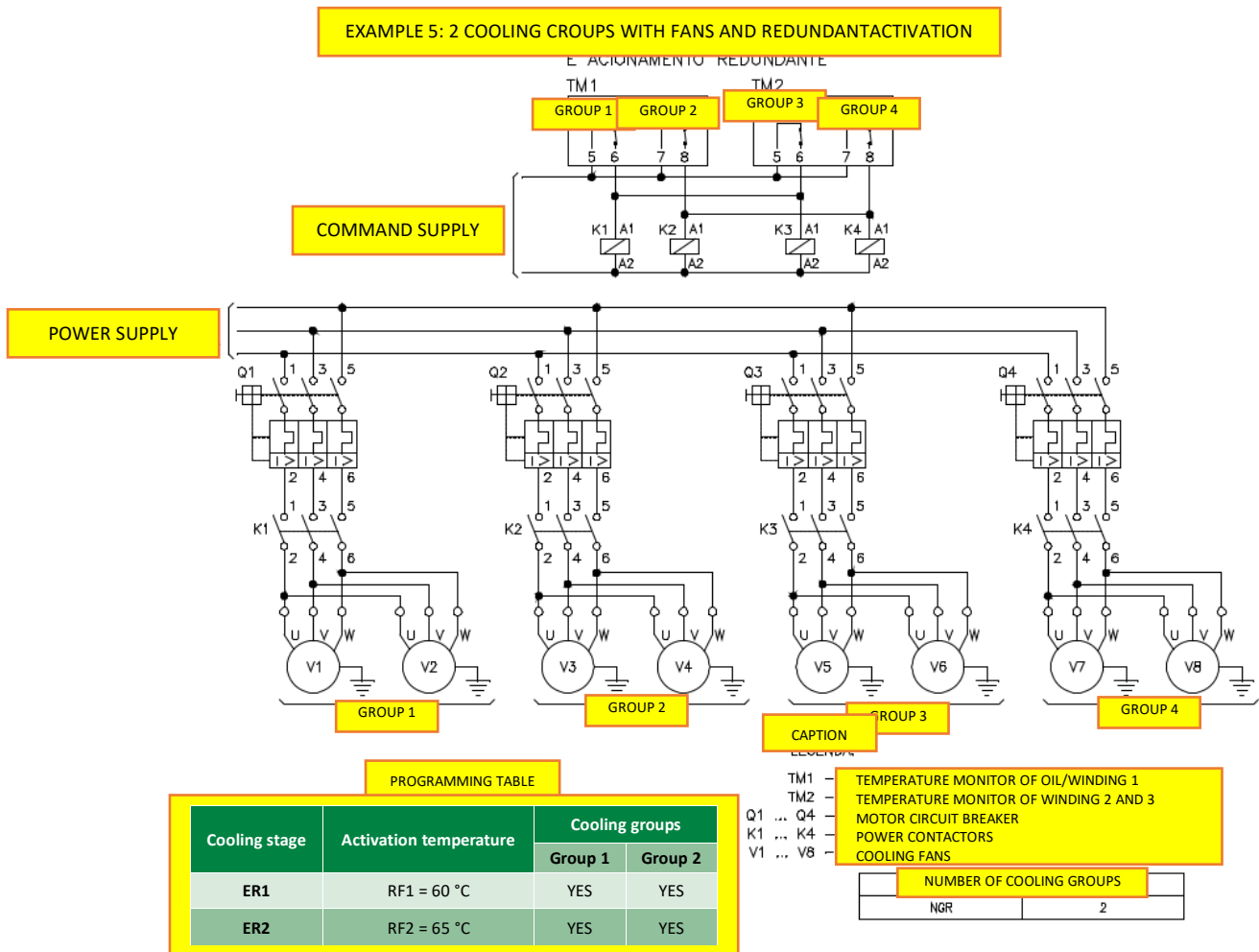
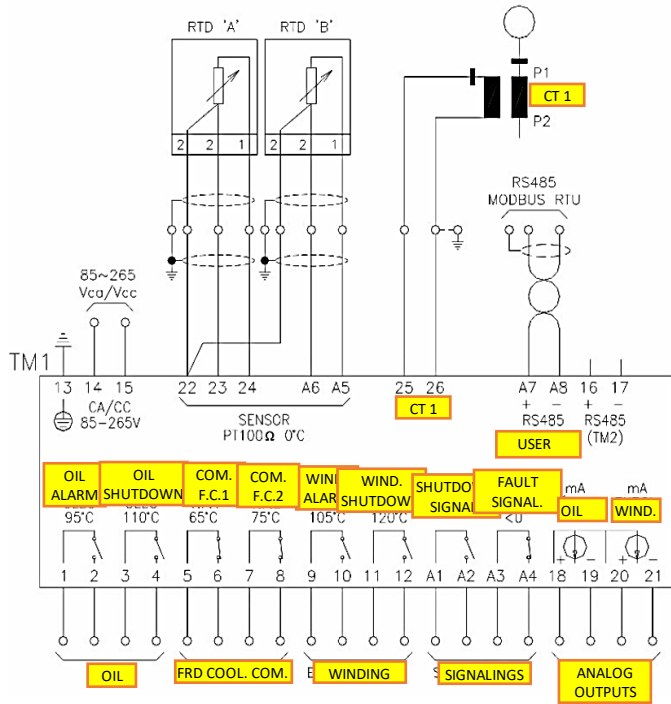

Figure 15 - Control system for 2 identical forced cooling groups with redundancy in the command

3.2.7 Typical application diagrams

RTD Sensors - OPTION 1



This connection option can be used:

- For redundant oil temperature measurement - in this case, both temperature sensors, A and B, must be located in the same region at the top of the oil;
- For measuring oil temperature with sensor A and a second temperature, for example, ambient or on-load tap changer temperature, with sensor B.

Figure 16 - Option 1 - 2 RTDs with 3 wires

RTD Sensors - OPTION 2

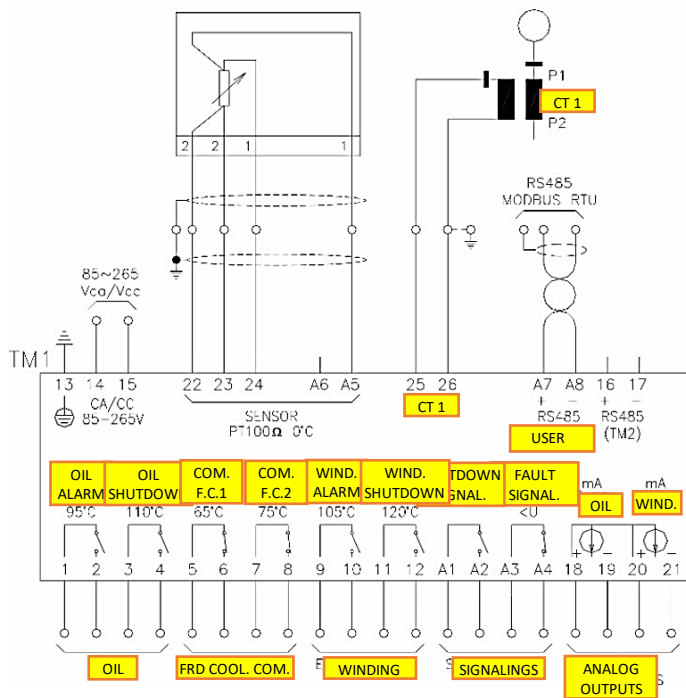

In this connection option, the temperature sensor should be used to measure the temperature of the top of the oil.

Figure 17 - Option 2 - 1 RTD with 4 wires



RTD Sensors - OPTION 3

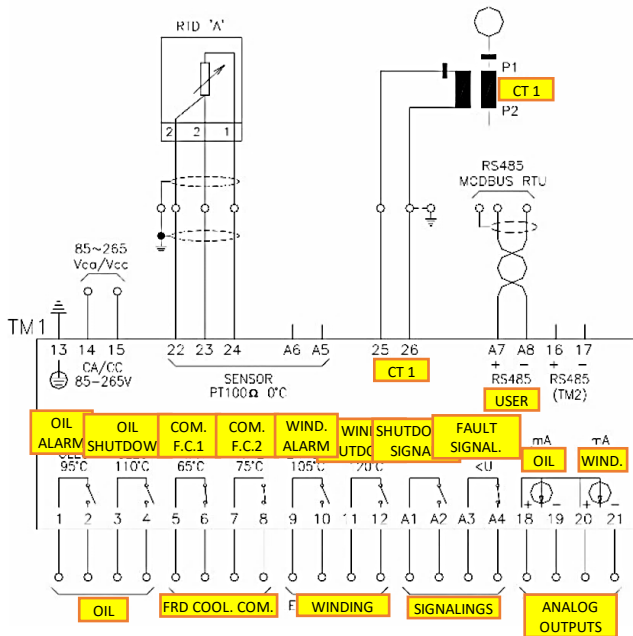

In this connection option, temperature sensor A should be used to measure the temperature of the top of the oil.

Figure 18 - Option 3 - 1 RTD with 3 wires, RTD "A"

RTD Sensors - OPTION 4

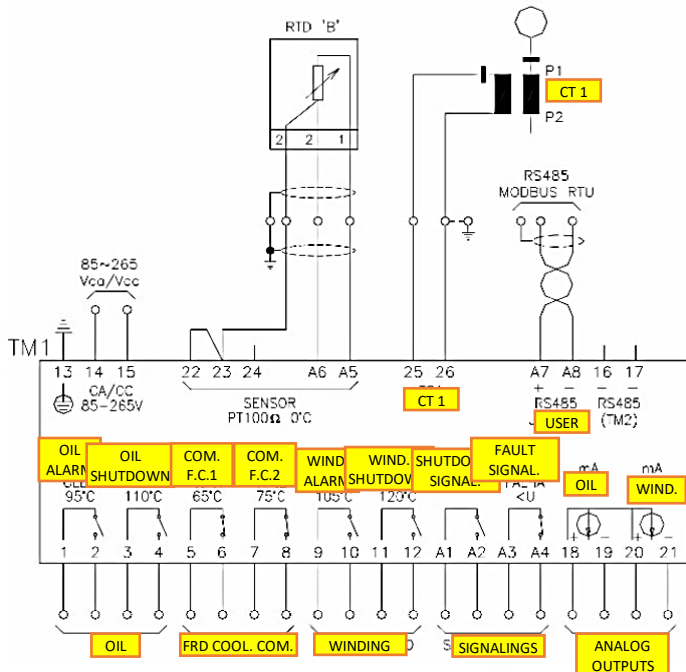

In this connection option, temperature sensor B should be used to measure the temperature of the top of the oil.

Figure 19 - Option 4 - 1 RTD with 3 wires, RTD "B"

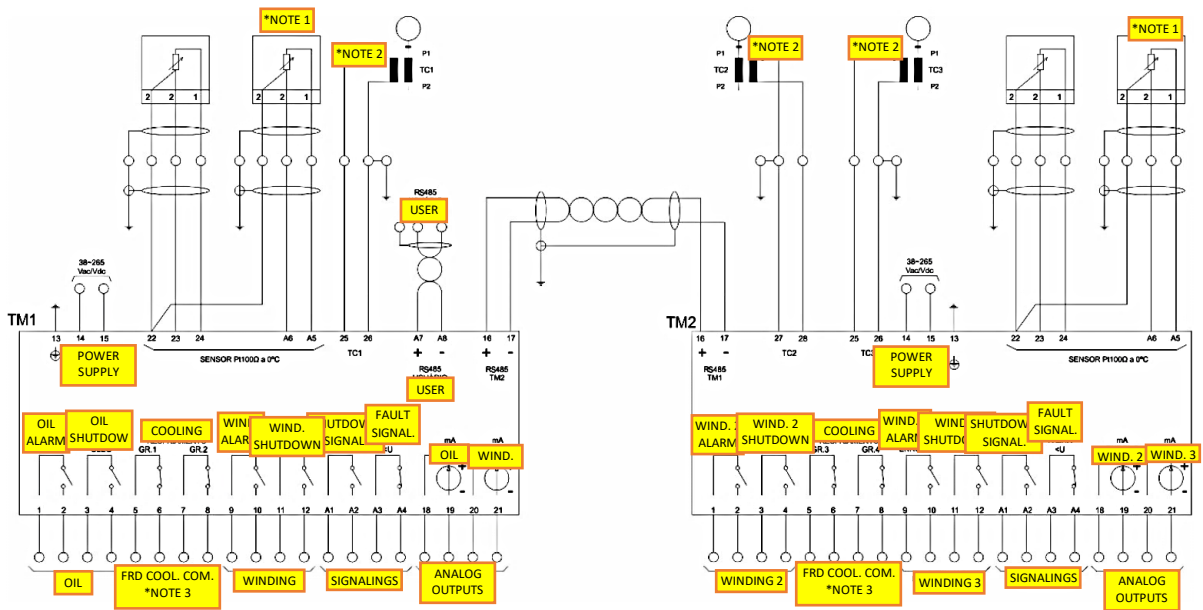

Figure 20 - TM1/TM2 connection diagram

Note 1: View RTD sensor connection options.

The temperature measurement of the oil top (1 or 2 sensors) must be connected to TM1.
The other RTD sensor inputs on TM1 and TM2 can be used by the user.

Note 2: The connection of the CTs must be made according to the model of the temperature monitor purchased.

For direct connection of 0-10 A CTs or for use with external window CTs (optional accessories).
See the technical manual for connection details.

Note 3: The cooling control contacts on TM2 can be used as redundancy for those on TM1, connecting them in parallel to control 2 cooling groups.

Note 4: All contacts are shown in the TM1 and TM2 de-energized condition.

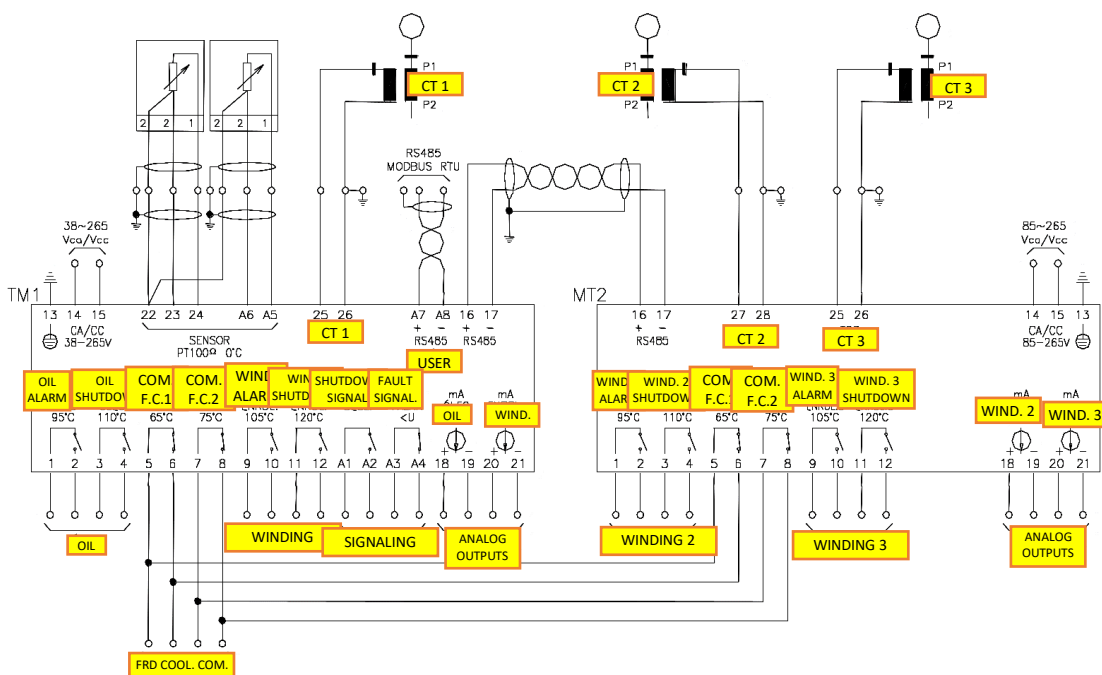

Figure 21 - TM1/MT2 connection diagram

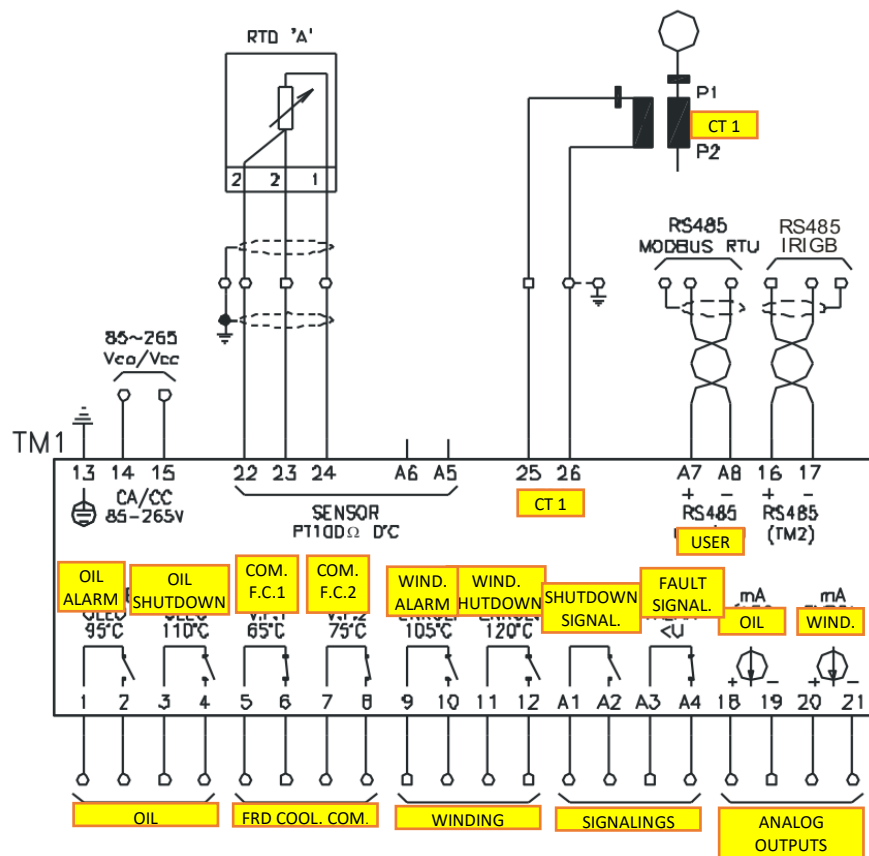

Figure 22 - TM1 connection to IRIG-B synchronization signal



Whenever using only the Pt100 from input B of TM1/TM2, verify the mandatory connection between points 22 and 23.

3.3 Mechanical installation

The Temperature Monitors should be installed protected from the elements, either inside panels or sheltered in buildings. In either case, an anti-condensation system must be in place.

The TM1 and TM2 Temperature Monitors are suitable for recessed installation and can be fixed, for example, to doors or front panels. Fixing clips are supplied with the devices. The figure below shows the main dimensions of the equipment, as well as the dimensions of the cutout in the panel for its insertion. Special attention should be paid to the thickness of the paint layers on the panel where the cutout is made, because in some cases, when high-thickness paint is used, the reduction in the cutout area may even prevent the insertion of the equipment. The connection terminals are installed on the back of the TM1 and TM2, in 2 removable connectors and in screw terminals (connection of the CTs for thermal imaging), in order to facilitate connections. Cables from 0.5 to 2.5 mm² can be used, bare or with "pin" (or "needle") type terminals for the removable connectors, and up to 6 mm² for the CT connectors with appropriate ring-type terminals.

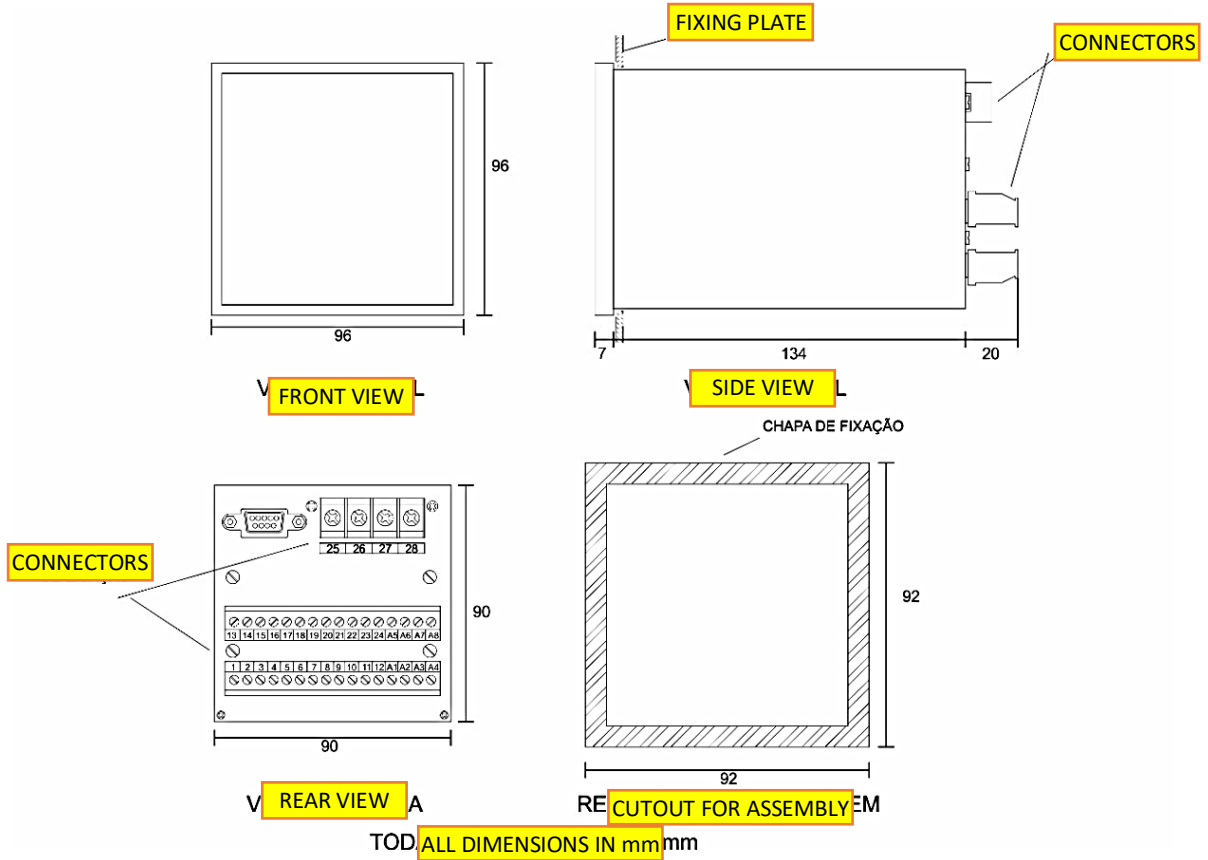

Figure 23 - TM1 and TM2 dimensions



4 Operation

All operations on the TM1 and TM2 Temperature Monitors are performed via the front panel keypad; no external selector switches are required. Oil, winding(s), and on-load tap changer (optional) temperatures will be displayed, and alarms, shutdowns, and forced cooling operations will be indicated by the signaling LEDs.

4.1 Initial indications

During normal operation, the Temperature Monitor will indicate the temperature of the oil and the winding(s) connected to it.

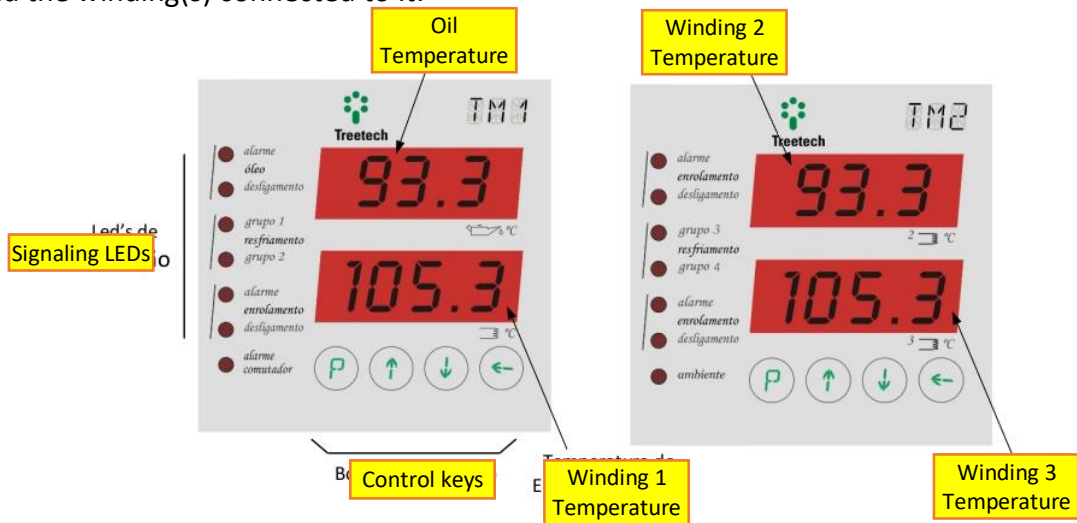

Figure 24 - Indications on TM1/TM2

When the programmed temperature value for an event is reached, the corresponding indicator LED will light up, also activating the output contact for that event.

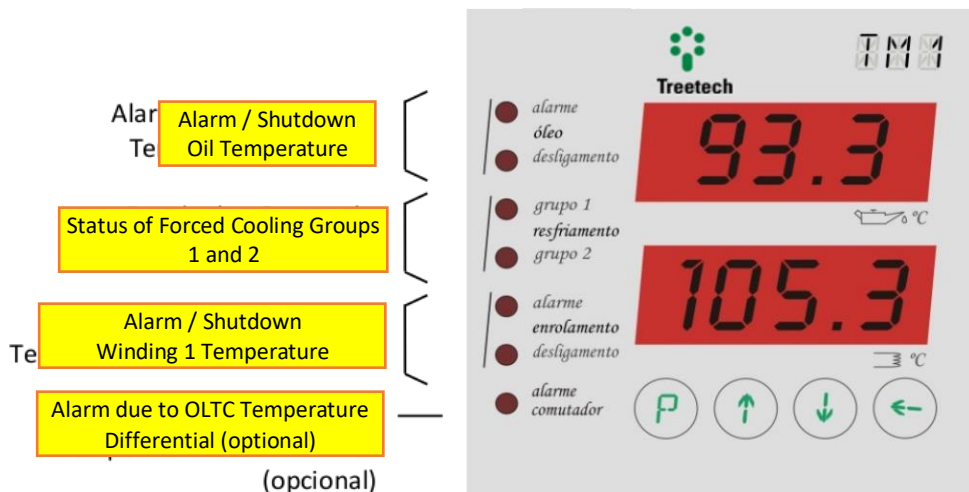

Figure 25 - TM1 signaling LEDs

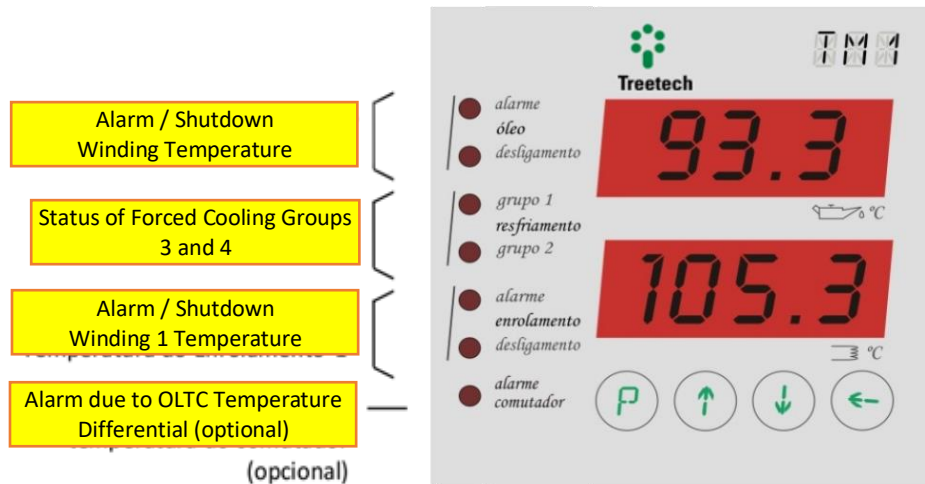

Figure 26 - TM2 signaling LEDs



If the PTA or PTB option is selected in the TM2's DSP parameter, the LED indicating this temperature display, instead of the winding 3 temperature (which is the default indication), lights up on the front of the TM2. This is the signal for the lower display indication mode, a TM2 DSP parameter.

If any anomaly occurs, the corresponding self-diagnosis code will be displayed on the screens.

4.2 Key functions

The keys have the following functions:

Table 5 - TM1/TM2 key functions



Key	Function
	Programming key: On the measurement screens, it allows you to check the equipment's firmware version and access the password to enter the programming menu. It switches between groups of measurement screens, selects menus and parameters, and saves programmed values.
	Up key: Navigation between measurement screens and between menus and programming parameters. During parameter editing, the programmed value increases.
	Down key: Navigation between measurement screens and between menus and programming parameters. During parameter editing, the programmed value decreases.
	Back key: Returns to the previous menu.





To easily check the firmware version of your TM1/TM2, simply press the and keys simultaneously for 0.5 seconds.





4.3 Query screens

The Temperature Monitors provide various information to guide you regarding the transformer's operating conditions. This information is accessed via the keys  and  during normal operating mode.



4.3.1 TM1 query screens

The following information will be displayed on the device's screens. Oil information will be shown on the upper display and winding 1 information on the lower display sequentially when the key  is pressed. Pressing the  key reverses the order shown below:

1. Maximum oil temperature (MAX)

- This is the maximum oil temperature reached during the period, shown on the upper display.
- To reset this record after a query, press and hold the  key and then press the  key. The reading will then match the ongoing oil temperature.

2. Maximum winding 1 temperature (MAX)

- This is the maximum temperature reached by winding 1 during the period, shown on the lower display.
- To reset this record after a query, press and hold the  key and then press the  key. The reading will then match the ongoing temperature of winding 1.

3. Final gradient (GFN)

- Indicates the difference between the oil and winding 1 temperatures after thermal stabilization, maintaining the ongoing load condition.

4. Percentage of load on the monitored winding (%)

- It is the load on the transformer, given as a percentage of the nominal current of the winding being monitored.

5. Current measured from the secondary of the CT (AMP)

- This is the current in the secondary winding of the thermal imaging CT monitored, given in amperes.

6. Winding current in kA

- This is the current in the transformer winding where the temperature is being monitored, given in kA.

7. Temperature sensor A measurement connected to TM1 (PTA)

- This is the temperature being measured by temperature sensor "A", given in °C.

8. Temperature sensor B measurement connected to TM1 (PTB)



- The device only displays this information if it is configured for two sensors (see "CNF" menu programming).
- It is the temperature measured by temperature sensor "B", in °C, which can be the oil temperature, ambient temperature, or another temperature, according to the programming in the "CNF" configuration menu.

9. Hour indication (HOR)

- Displays the hour on the device's internal clock.

10. Minute indication (MIN)

- Displays the minutes on the device's internal clock.

11. Seconds indication (SEG)

- Displays the seconds on the device's internal clock.

12. Day indication (DIA)

- Displays the day on the device's internal calendar.

13. Month indication (MES)

- Displays the month on the device's internal calendar.

14. Year indication (ANO)

- Displays the year on the device's internal calendar.

15. OLTC temperature differential (DTC)

- This indication will only be shown if the TM1 has this optional function.

15.1 DT1 - Instantaneous temperature differential of the on-load tap changer 1

15.2 DT2 - Instantaneous temperature differential of the on-load tap changer 2

15.3 DT3 - Instantaneous temperature differential of the on-load tap changer 3

15.4 DF1 - Filtered temperature differential of the on-load tap changer 1.

15.5 DF2 - Filtered temperature differential of the on-load tap changer 2.

15.6 DF3 - Filtered temperature differential of the on-load tap changer 3.

15.7 AAA - Time remaining for the completion of the Automatic Adjustment of the Alarms due to OLTC Temperature Differential, in hours. The value 0 (zero) indicates that the learning process for automatic adjustment is not in progress.

15.8 DTC / MIN - Consultation of the minimum values reached by temperature differentials during the period.





- **DT1 / MIN** - Minimum value reached by the instantaneous differential of OLTC 1.
- **DT2 / MIN** - Minimum value reached by the instantaneous differential of OLTC 2.
- **DT3 / MIN** - Minimum value reached by the instantaneous differential of OLTC 3.
- **DF1 / MIN** - Minimum value reached by the filtered differential of OLTC 1.
- **DF2 / MIN** - Minimum value reached by the filtered differential of OLTC 2.
- **DF3 / MIN** - Minimum value reached by the filtered differential of OLTC 3.





15.9 DTC / MAX - Consultation of the maximum values reached by temperature differentials during the period.

- **DT1 / MAX** - Maximum value reached by the instantaneous differential of OLTC 1.
- **DT2 / MAX** - Maximum value reached by the instantaneous differential of OLTC 2.
- **DT3 / MAX** - Maximum value reached by the instantaneous differential of OLTC 3.
- **DF1 / MAX** - Maximum value reached by the filtered differential of OLTC 1.
- **DF2 / MAX** - Maximum value reached by the filtered differential of OLTC 2.
- **DF3 / MAX** - Maximum value reached by the filtered differential of OLTC 3.
- **TC1 / MAX** - Maximum value reached by the temperature of OLTC 1.
- **TC2 / MAX** - Maximum value reached by the temperature of OLTC 2.
- **TC3 / MAX** - Maximum value reached by the temperature of OLTC 3.

4.3.2 TM2 query screens

The following information will be displayed on the device's screens sequentially when the  key is pressed. Pressing the  key will display the reverse order shown below. The information for winding 2 is shown on the upper display, and the information for winding 3 on the lower display.

1. Maximum winding 2 temperature (MÁX)

- This is the maximum temperature reached by winding 2 during the period.
- To reset this record after a query, press and hold the  key and then press  key. The reading will then match the ongoing temperature of winding 2.

2. Final gradient of winding 2 (GFN)

- Indicates the difference between the oil and winding 2 temperatures after thermal stabilization, maintaining the ongoing load condition.

3. Percentage of winding 2 load (%)

- This is the percentage load of winding 2, relative to the nominal current of that winding.

4. Current measured from the secondary of auxiliary CT 2 (AMP)



- This is the current in the secondary winding of the thermal imaging CT for winding 2, given in amperes.

5. Current of winding 2 in kA (KA)

- This is the current in winding 2 of the transformer, where the temperature is being monitored, given in kA.

6. Maximum winding 3 temperature (MAX)



- This is the maximum temperature reached by winding 3 during the period.
- To reset this record after a query, press and hold the  key and then press the  key. The reading will then match the current temperature of winding 3.

7. Final gradient of winding 3 (GFN)

- Indicates the difference between the oil and winding 3 temperatures after thermal stabilization, maintaining the ongoing load condition.

8. Percentage of winding 3 load (%)

- This is the percentage load of winding 3, relative to the nominal current of that winding.

9. Current measured from the secondary of auxiliary CT 3 (AMP)

- This is the current in the secondary winding of the thermal imaging CT for winding 3, given in amperes.

10. Winding current 3 in kA (KA)

- This is the current in winding 3 of the transformer, where the temperature is being monitored, given in kA.

11. Temperature sensor A measurement connected to TM2 (PTA)

- This is the temperature being measured by temperature sensor A, given in °C. This reading will only be displayed if RTD input A of the TM2 is enabled.

12. Temperature sensor B measurement connected to TM2 (PTB).

- This is the temperature being measured by temperature sensor B, given in °C. This reading will only be displayed if the RTD B input of the TM2 is enabled.

4.4 Commands

By pressing the  key, we can access forced cooling groups 1 to 4 (RF1 to RF4), and change their state between “ON” (activated) and “AUT” (automatic) to manually turn them on or keep their control in automatic mode through the programmed settings.





5 Parameterization

To ensure the correct operation of the system, several parameters must be adjusted in TM1 and TM2 to provide the equipment with the necessary information for its operation. Adjustments can be made via the front keypad, with the aid of the display, or via parameterization software through the RS-232 or RS-485 serial communication ports available to the user on the rear panel of the device. The programmable parameters are organized into menus with password-protected access. In the main menu, the user will have access to programming submenus, where they can navigate and adjust values according to the transformer's characteristics and user needs.

5.1 Access to programming menus

To access the programming menu for Monitors TM1 and TM2, follow the procedure below:

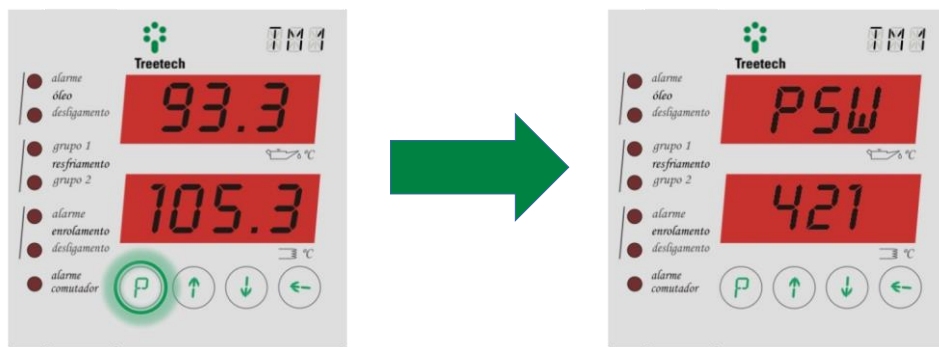

1) On the temperature display screen, press and hold the **P** key for 5 seconds

2) The password screen will be displayed.

3) Use the keys **P** and **↓** to adjust the password. (range = 0 to 999).
If the initial reading is 421, then the password is "0", which is the original factory value.
This password can be changed by the user.

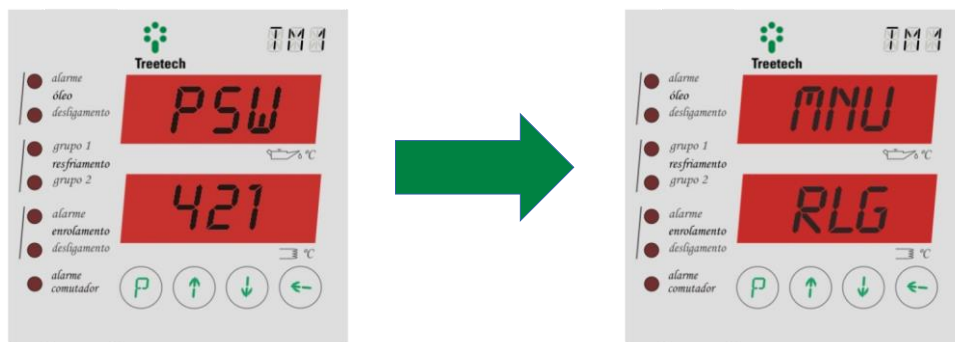

4) After setting the password, press and release the **P** key to enter the programming menu

5) Main menu screen, where you can navigate to the programming submenus.



5.2 Parameter map

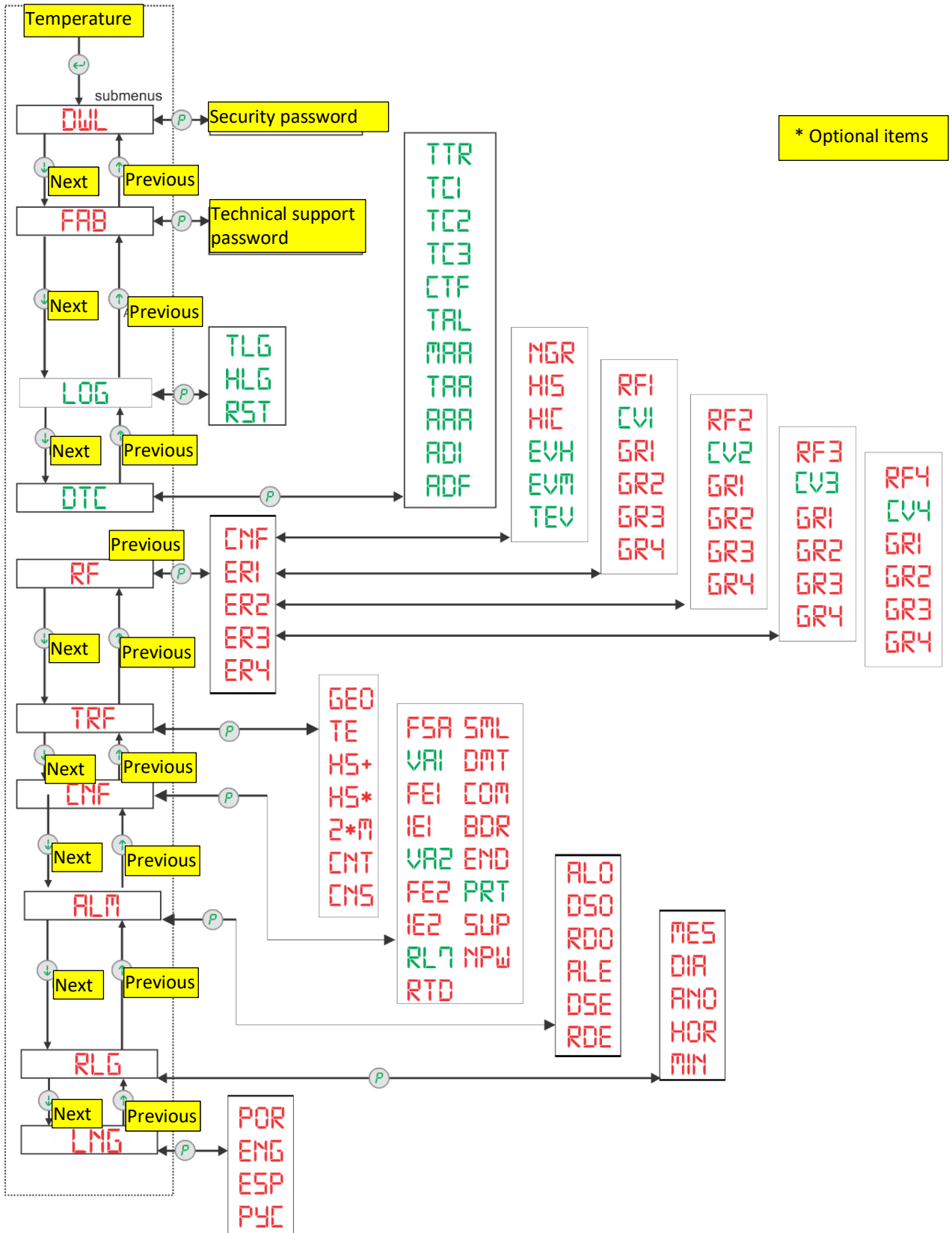



5.3 LNG Menu

Allows you to adjust the display language of the device. This adjustment is made on TM1/TM2.



IDI - Language

Select the language you want for the product interface.

Adjustment range:

- POR = Portuguese;
- ENG = English;
- ESP = Spanish;
- PYC = Russian.



Idioma padrão: Portuguese

5.4 RLG Menu

Allows you to adjust the clock and calendar on the device. This adjustment can only be made on the TM1.

Optionally, the clock can be adjusted using the DNP3 protocol or the IRIG-B input, if available, which synchronize the clock via GPS.



MES - Month

Adjusting the ongoing month in the device's calendar.

Adjustment range: 1 to 12, in 1-month steps.

Default value: 0.



DIA - Day

Adjusting the ongoing day in the device's calendar.

Adjustment range: 1 to 31, in 1-day steps.

Default value: 0.



ANO - Year

Adjusting the ongoing year in the device's calendar.

Adjustment range: 0 to 99, in 1-year steps.

Default value: 0.



HORA - Hour





Adjusting the ongoing hour on the device's clock.

Adjustment range: 0 to 23, in 1-hour steps.

Default value: 0.

MIN - Minute

Adjusting the minutes on the device's clock.

Adjustment range: 0 to 59, in 1-minute steps.

Default value: 0.



5.5 ALM Menu

Allows access to all parameters related to alarms and shutdowns. Extended temperature range of -55 to 200 °C for 4-key hardware and 0 to 150 °C for 3-key hardware.



5.5.1 ALM Menu - TM1

ALO – Alarm due to oil

Sets the alarm value for oil temperature. Once activated, the alarm is only deactivated if the temperature drops 1°C or more below the activation value.

Adjustment range: -55 to 200 °C, in 1 °C steps.

Default value: 95 °C.



DSO – Shutdown due to oil

Determines the value for oil temperature shutdown. Once activated, the alarm is only deactivated if the temperature drops 1°C or more below the activation value. It can also be used as a second-level alarm if automatic transformer shutdown is not desired.

Adjustment range: -55 to 200 °C, in 1 °C steps.

Default value: 110 °C.



RDO – Delay for shutdown due to oil

Allows you to insert a delay between the moment the oil temperature reaches the shutdown value and the instant when the shutdown signal and associated output relays are actually activated.

Adjustment range: 0 to 20 min., in 0.1 min steps.

Default value: 5 min.





ALE – Alarm due to winding 1

Sets the temperature alarm value for winding 1. Once activated, the alarm is only deactivated if the temperature drops 1°C or more below the activation value.



Adjustment range: -55 to 200 °C, in 1 °C steps.

Default value: 105 °C.

DSE – Shutdown due to winding 1

Determines the temperature-based shutdown value for winding 1. Once activated, the alarm is only deactivated if the temperature drops 1°C or more below the activation value. It can also be used as a second-level alarm if automatic transformer shutdown is not desired.



Adjustment range: -55 to 200 °C, in 1 °C steps.

Default value: 120 °C.

RDE – Delay for shutdown due to winding 1

Allows you to insert a delay between the moment when the temperature of winding 1 reaches the value for shutdown and the instant when the shutdown signal and the associated output relays are actually activated.



Adjustment range: 0 to 20 min., in 0.1 min steps.

Default value: 5 min.

5.5.2 ALM Menu - TM2

ALE – Alarm due to winding 2

Sets the temperature alarm value for winding 2. Once activated, the alarm is only deactivated if the temperature drops 1°C or more below the activation value.



Adjustment range: -55 to 200 °C, in 1 °C steps.

Default value: 105 °C.

DSE – Shutdown due to winding 2

Determines the temperature-based shutdown value for winding 2. Once activated, the alarm is only deactivated if the temperature drops 1°C or more below the activation value. It can also be used as a second-level alarm if automatic transformer shutdown is not desired.



Adjustment range: -55 to 200 °C, in 1 °C steps.

Default value: 120 °C.



RDE – Delay for shutdown due to winding 2

Allows you to insert a delay between the moment when the temperature of winding 2 reaches the value for shutdown and the instant when the shutdown signal and the associated output relays are actually activated.



Adjustment range: 0 to 20 minutes, in 0.1 minute steps.

Default value: 5 min.

ALE – Alarm due to winding 3

Sets the temperature alarm value for winding 3. Once activated, the alarm is only deactivated if the temperature drops 1°C or more below the activation value.



Adjustment range: -55 to 200 °C, in 1 °C steps.

Default value: 105 °C.

DSE – Shutdown due to winding 3

Determines the temperature-based shutdown value for winding 3. Once activated, the alarm is only deactivated if the temperature drops 1°C or more below the activation value. It can also be used as a second-level alarm if automatic transformer shutdown is not desired.



Adjustment range: -55 to 200 °C, in 1 °C steps.

Default value: 120 °C.

RDE – Delay for shutdown due to winding 3

Allows you to insert a delay between the moment when the temperature of winding 3 reaches the value for shutdown and the instant when the shutdown signal and the associated output relays are actually activated.



Adjustment range: 0 to 20 minutes, in 0.1 minute steps.

Default value: 5 min.



5.6 CNF Menu

5.6.1 CNF Menu - TM1

FSA - Analog output range (mA)

Selects the current loop output range for remote indication.



Adjustment range:

- 0 = 0...1 mA;
- 1 = 0...5 mA;
- 2 = 0...10 mA;
- 3 = 0...20 mA;
- 4 = 4...20 mA.

Default value: 4

VA1 - Analog variable 1

Selection of the variable associated with analog output 1. If the **OLTC Temperature Differential** option is not enabled and one of the variables from 9 to 16 is selected, the current at the output will be zero.



Adjustment range:

- 0 - Temperature of oil;
- 1 - Temperature of winding 1;
- 2 - Temperature of winding 2;
- 3 - Temperature of winding 3;
- 4 - Temperature of the hottest winding;
- 5 - Temperature sensor A (PTA) connected to TM1;
- 6 - Temperature sensor B (PTB) connected to TM1;
- 7 - Temperature sensor A (PTA) connected to TM2;
- 8 - Temperature sensor B (PTB) connected to TM2;
- 9 - Instantaneous temperature differential of OLTC 1;
- 10 - Instantaneous temperature differential of OLTC 2;
- 11 - Instantaneous temperature differential of OLTC 3;
- 12 - Largest instantaneous differential among the 3 OLTCs;
- 13 - Filtered temperature differential of OLTC 1;
- 14 - Filtered temperature differential of OLTC 2;
- 15 - Filtered temperature differential of OLTC 3;
- 16 - Largest filtered differential among the 3 OLTCs.

Default value: 0.



FE1 - End of scale 1

Define the correspondence between the final current of analog output 1 and the last value on the scale of the measured quantity 1.



Adjustment range: -55 to 200, in steps of 1.

Default value: 150.

IE1 - Start of scale of current output 1

Define the correspondence between the initial current of analog output 1 and the first value on the scale of the measured quantity 1.

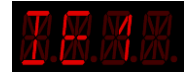

Adjustment range: -55 to 200, in steps of 1.

Default value: 0.

VA2 - Analog variable 2

Selection of the variable associated with current output 2. If the **OLTC Temperature Differential** option is enabled, any of the 17 variables can be selected. If this option is not enabled and one of the variables from 9 to 16 is selected, the current at the output will be zero.



Adjustment range:

- 0 - Temperature of oil;
- 1 - Temperature of winding 1;
- 2 - Temperature of winding 2;
- 3 - Temperature of winding 3;
- 4 - Temperature of the hottest winding;
- 5 - Temperature sensor A (PTA) connected to TM1;
- 6 - Temperature sensor B (PTB) connected to TM1;
- 7 - Temperature sensor A (PTA) connected to TM2;
- 8 - Temperature sensor B (PTB) connected to TM2;
- 9 - Instantaneous temperature differential of OLTC 1;
- 10 - Instantaneous temperature differential of OLTC 2;
- 11 - Instantaneous temperature differential of OLTC 3;
- 12 - Largest instantaneous differential among the 3 OLTCs;
- 13 - Filtered temperature differential of OLTC 1;
- 14 - Filtered temperature differential of OLTC 2;
- 15 - Filtered temperature differential of OLTC 3;
- 16 - Largest filtered differential among the 3 OLTCs.

Default value: 1



FE2 - End of scale 2

Define the correspondence between the final current of analog output 2 and the last value on the scale of the measured quantity 2.



Adjustment range: -55 to 200 °C in 1 °C steps.

Default value: 150.

IE2 - Start of scale 2

Define the correspondence between the initial current of analog output 2 and the first value on the scale of the measured quantity 2.



Adjustment range: -55 to 200 °C in 1 °C steps.

Default value: 0.

RL7 - Output relay 7

Selection of the signaling function associated with output relay 7. This parameter will only be displayed if the **OLTC Temperature Differential** option is present. Otherwise, the relay assumes the standard instantaneous shutdown signaling function.



Adjustment range:

- 0 - Instantaneous shutdown signaling;
- 1 - Alarm due to instantaneous temperature differential;
- 2 - Alarm due to filtered temperature differential;
- 3 - Alarm due to instantaneous or filtered temperature differentials.

Default value: 3.

RTD - Temperature sensor configuration

Selecting the temperature sensor configuration option.



Adjustment range:

2X3 = 2 redundant Pt100 3-wire sensors for oil temperature;

1X4 = 1 Pt100 4-wire sensor for oil temperature;

X3A = 1 Pt100 3-wire sensor on input A for oil temperature.;

X3B = 1 Pt100 3-wire sensor on input B for oil temperature (See wiring diagram 4.14 for details);

O+A = 2 Pt100 3-wire sensors to measure oil temperature (sensor A) and another temperature, for example, ambient or tap changer temperature (sensor B).

Default value: X3A.



SML - RTD electronic simulator

Verification of Pt100 inputs using an electronic RTD simulator.

During normal system operation, this parameter should be set to “OFF”. Each time the device is switched off and on again, this parameter reverts to the “OFF” setting.



Adjustment range:

ON = Use an external Pt100 sensor electronic simulator for simulation.
OFF = Use Pt100 for temperature reading.

Default value: OFF

DMT - Maximum temperature difference

Maximum permissible temperature difference between the two 3-wire Pt100 sensors when using the 2x3 option in the RTD parameter.



Adjustment range: 1 to 6 °C, in 0.1 °C steps.

Default value: 1 °C.

COM - Communication

Selection of the communication port to be used.



Adjustment range:

232 = use the RS-232 serial (DB9 connector);
485 = use the RS-485 serial (terminals A7 and A8).

Default value: 485.

BDR - Baud rate

Selection of the data transmission speed.



Adjustment range:

9.6 = speed of 9.6 kbps;
19.2 = speed of 19.2 kbps;
38.4 = speed of 38.4 kbps.

Default value: 9.6.



END - Address

Selection of the device's address on the communication network, used for data acquisition.



Adjustment range: 1 to 31, in steps of 1.

Default value: 1.

PRT - Protocol

Type of protocol to be used for communication with the data acquisition device.



This is an optional module and will only be displayed if it is enabled.

Adjustment range:

Mdb = Modbus;

DNP = DNP3 with 1ms timestamp.

Default value: Modbus.

SUP - Supervision mode

This refers to which devices are connected to the local network. If the value is 0 (only TM1) and TM2 is connected to TM1, then TM1 will not display TM2's data until this parameter is adjusted to the correct connection, which would be the value 1. The same logic applies to connections with MT2 or IRIG-B.



Adjustment range:

0 = TM1 only;

1 = TM1 + TM2;

2 = Not Used (reserved option);

3 = Not Used (reserved option);

4 = TM1 + MT2;

5 = TM1 + IRIG-B.

Note:

1) Using TM1 + MT2 (SUP = 4), the address of MT2 should be 1.

2) Using the TM1 + IRIG-B connection, it is not possible to use TM2.

NPW - New password

Setting a new password to access the programming menus.



Adjustment range: 0 to 999 in steps of 1;

Default value = 0.



5.6.2 CNF Menu - TM2

FSA - Analog output range (mA)

Select the current loop pattern for remote indication;



Adjustment range:

- 0 = 0...1mA;
- 1 = 0...5mA;
- 2 = 0...10mA;
- 3 = 0...20mA;
- 4 = 4...20mA.

Default value: 4.

VA1 - Variable associated with current output 1

Selecting the variable associated with current output 1. If the **OLTC temperature differential** option is enabled, any of the 17 variables can be selected. If this option is not enabled and one of the variables from 9 to 16 is selected, the current at the output will be zero.



Adjustment range:

- 0 - Temperature of oil;
- 1 - Temperature of winding 1;
- 2 - Temperature of winding 2;
- 3 - Temperature of winding 3;
- 4 - Temperature of the hottest winding;
- 5 - Temperature sensor A (PTA) connected to TM1;
- 6 - Temperature sensor B (PTB) connected to TM1;
- 7 - Temperature sensor A (PTA) connected to TM2;
- 8 - Temperature sensor B (PTB) connected to TM2;
- 9 - Instantaneous temperature differential of OLTC 1;
- 10 - Instantaneous temperature differential of OLTC 2;
- 11 - Instantaneous temperature differential of OLTC 3;
- 12 - Largest instantaneous differential among the 3 OLTCs;
- 13 - Filtered temperature differential of OLTC 1;
- 14 - Filtered temperature differential of OLTC 2;
- 15 - Filtered temperature differential of OLTC 3;
- 16 - Largest filtered differential among the 3 OLTCs.

Default value: 2.



FE1 - End of scale 1

Define the correspondence between the final current of analog output 1 and the last value on the scale of the measured quantity 1.



Adjustment range: -55 to 200 °C in 1 °C steps.

Default value: 150.

IE1 - Start of scale 1

Define the correspondence between the initial current of analog output 1 and the first value on the scale of the measured quantity 1.



Adjustment range: -55 to 200 °C, in 1 °C steps.

Default value: 0.

VA2 - Variable associated with current output 2

Selection of the variable associated with current output 2. If the **OLTC Temperature Differential** option is enabled, any of the 17 variables can be selected. If this option is not enabled and one of the variables from 9 to 16 is selected, the current at the output will be zero.



Adjustment range:

- 0 - Temperature of oil;
- 1 - Temperature of winding 1;
- 2 - Temperature of winding 2;
- 3 - Temperature of winding 3;
- 4 - Temperature of the hottest winding;
- 5 - Temperature sensor A (PTA) connected to TM1;
- 6 - Temperature sensor B (PTB) connected to TM1;
- 7 - Temperature sensor A (PTA) connected to TM2;
- 8 - Temperature sensor B (PTB) connected to TM2;
- 9 - Instantaneous temperature differential of OLTC 1;
- 10 - Instantaneous temperature differential of OLTC 2;
- 11 - Instantaneous temperature differential of OLTC 3;
- 12 - Largest instantaneous differential among the 3 OLTCs;
- 13 - Filtered temperature differential of OLTC 1;
- 14 - Filtered temperature differential of OLTC 2;
- 15 - Filtered temperature differential of OLTC 3;
- 16 - Largest filtered differential among the 3 OLTCs.

Default value: 3.



FE2 - End of scale 2

Define the correspondence between the final current of analog output 2 and the last value on the scale of the measured quantity 2.



Adjustment range: -55 to 200 °C in 1 °C steps.

Default value: 150.

IE2 - Start of scale 2

Define the correspondence between the initial current of analog output 2 and the first value on the scale of the measured quantity 2.



Adjustment range: -55 to 200 °C in 1 °C steps.

Default value: 0.

RL7 - Output relay 7 signaling function (optional)

Selection of the signaling function associated with output relay 7. This parameter will only be displayed if the **OLTC Temperature Differential** is present. Otherwise, the relay assumes the standard instantaneous shutdown signaling function.



Adjustment range:

- 0 - Instantaneous shutdown signaling - one or more shutdown contacts actuated or timed;
- 1 - Alarm due to instantaneous temperature differential;
- 2 - Alarm due to filtered temperature differential;
- 3 - Alarm due to instantaneous or filtered temperature differentials.

Default value: 3.

RTD - Temperature sensor configuration

Selection of the temperature sensor configuration option.



Adjustment range:

OFF;

2X3 = 2 redundant 3-wire Pt100 sensors for oil temperature;

1X4 = 1 Pt100 4-wire sensor for oil temperature;

X3A = 1 Pt100 3-wire sensor on input A for oil temperature;

X3B = 1 Pt100 3-wire sensor on input B for oil temperature (See wiring diagram in Figure 19 for more details);

O+A = 2 Pt100 3-wire sensors to measure oil temperature (sensor A) and another temperature, for example, ambient or switchgear temperature (sensor B);

Default value: OFF.



SML - RTD electronic simulator

Verification of Pt100 inputs using an electronic RTD simulator.

During normal system operation, this parameter should be set to “OFF”. Each time the device is switched off and on again, this parameter reverts to the “OFF” setting.



Adjustment range:

ON = Use an external Pt100 sensor electronic simulator for simulation.

OFF = Use Pt100 for temperature reading.

Default value: OFF.

END - Address

Device address for communication with TM1.

When using the TM1+TM2 configuration, this parameter must be 1.



Adjustment range: 1 to 31, in steps of 1.

Default value: 1.

DSP - Display

Indicates which variable will be shown on the display corresponding to winding 3, present in TM2. This display occurs on the lower screen of TM2.



Adjustment range:

- EN3: Displays the calculated temperature for winding 03.;
- PTA: Displays the temperature read by the Pt100 at input A;
- PTB: Displays the temperature read by the Pt100 at input B.

Default value: EN3.

NPW - New password

Setting a new password to access the programming menus.

Adjustment range: 0 to 999, in steps of 1.

Default value: 0.



5.7 TRF Menu

It allows access to parameters related to the characteristics of the transformer/reactor.





5.7.1 TRF Menu - TM1

GEO - Oil/winding 1 temperature gradient

This value is usually provided by the transformer/reactor manufacturer, who obtains it from heating tests or calculations.



GEO is defined by IEC 60076-7 as the difference between the average winding temperature and the average oil temperature, after thermodynamic stabilization of the transformer at nominal load.

In NBR 5416 / IEEE C57.91-1995, **GEO** is defined as the rise in the average winding temperature relative to the top oil temperature, after the thermodynamic stabilization of the transformer at nominal load.

Adjustment range: 0 to 50 °C, in 0.1 °C steps.

Default value: 10 °C.

TE - Winding 1 time constant

It is the time constant in seconds, related to the thermal inertia of winding 1 of the transformer.



This parameter can be measured during the heating test or calculated by the transformer manufacturer. If it is not possible to obtain it by either of these two methods, the typical value of 300 s may be adopted.

Adjustment range: 72 to 999 seconds, in steps of 1.

Default value: 300 seconds.

HS+ - Hot-spot factor (NBR 5416/IEEE C57.91-1995)

It is the difference between the temperature of the hottest point (hot-spot) and the average temperature of the winding, according to the model adopted by the ABNT NBR 5416 and IEEE C57.91-1995 standards.



If these standards are not selected, this parameter must be set to 0 (zero).

Adjustment range: 0 to 20 °C, in 0.1 °C steps.

Default value: 0.

HS* - Hot-spot factor (IEC - 60076-7)

It is the ratio between the temperature rise of the hottest point relative to the top oil temperature and the average winding temperature rise relative to the average oil temperature, according to the model adopted by the IEC 60076-7 standard. If this standard is not selected, this parameter must be programmed to 1 (one).



Adjustment range: 1 to 1.5 in 0.01 steps.

Default value: 1.



2*M - Winding exponent

Constant defined by the type of transformer cooling.

The value of this parameter is equal to twice the exponent of the winding temperature rise due to copper losses.



Adjustment range:

- 1,6 (natural oil and forced oil);
- 1,8 (use not yet foreseen in regulations);
- 2,0 (directed oil).

Default value: 1.8.

CNT - Nominal current of winding 1 of the transformer

Nominal current of winding 1 of the transformer, where the temperature is being determined.



Adjustment range: 0 to 9.999 kA in 0.001 kA steps.

Default value: 1.670 kA.

CNS - Current in the secondary of the thermal imaging CT of winding 1

Current in the secondary of the thermal imaging CT of winding 1, with the transformer under nominal load conditions.



Formula: $CNS = CNT / CT \text{ ratio}$

Adjustment range: 0.5 to 10A in 0.01A steps.

Default value: 0.5 A.

5.7.2 TRF Menu - TM2

GEO - Oil/winding 2 temperature gradient

This value is usually provided by the transformer/reactor manufacturer, who obtains it from heating tests or calculations.



GEO is defined by IEC 60076-7 as the difference between the average winding temperature and the average oil temperature, after thermodynamic stabilization of the transformer at nominal load.

In NBR 5416 / IEEE C57.91-1995, **GEO** is defined as the rise in the average winding temperature relative to the top oil temperature, after the thermodynamic stabilization of the transformer at nominal load.

Adjustment range: 0 to 50 °C, in 0.1 °C steps.

Default value: 10°C



TE - Winding 2 time constant

It is the time constant in seconds, related to the thermal inertia of winding 2 of the transformer.

This parameter can be measured during the heating test or calculated by the transformer manufacturer. If it is not possible to obtain it by either of these two methods, the typical value of 300 s may be adopted.



Adjustment range: 72 to 999, in steps of 1.

Default value: 300.

CNT - Nominal current of winding 2 of the transformer

Nominal current of winding 2 of the transformer, where the temperature is being determined.



Adjustment range: 0 to 9.999 kA in 0.001 kA steps.

Default value: 1.670.

CNS - Current in the secondary of the thermal imaging CT of winding 2

Current in the secondary of the thermal imaging CT of winding 2, with the transformer under nominal load conditions.



Formula: $CNS = CNT / CT \text{ ratio}$

Adjustment range: 0.5 to 10A in 0.01A steps.

Default value: 0.5.

GEO - Oil/winding 3 temperature gradient

This value is usually provided by the transformer/reactor manufacturer, who obtains it from heating tests or calculations.

GEO is defined by **IEC 60076-7** as the difference between the average winding temperature and the average oil temperature, after thermodynamic stabilization of the transformer at nominal load.



In **NBR 5416 / IEEE C57.91-1995**, **GEO** is defined as the rise in the average winding temperature relative to the top oil temperature, after the thermodynamic stabilization of the transformer at nominal load.

Adjustment range: 0 to 50 °C, in 0.1 °C steps.

Default value: 10.

TE – Winding 3 time constant

It is the time constant in seconds, related to the thermal inertia of winding 3 of the transformer.

This parameter can be measured during the heating test or calculated by the transformer manufacturer. If it is not possible to obtain it by either of these two methods, the typical value of 300 s may be adopted.



Adjustment range: 72 to 999 seconds, in 1-second steps.



Default value: 300 seconds.

CNT - Nominal current of winding 3 of the transformer

Nominal current of winding 3 of the transformer, where the temperature is being determined.



Adjustment range: 0 to 9.999 kA in 0.001 kA steps.

Default value: 1.670.

CNS - Current in the secondary of the thermal imaging CT of winding 3

Current in the secondary of the thermal imaging CT of winding 3, with the transformer under nominal loading conditions.



Fórmula: $CNS = CNT / CT \text{ ratio}$

Adjustment range: 0.5 to 10A in 0.01A steps.

Default value: 0.5.

5.8 RF Menu

Allows access to parameters related to the operating settings of the transformer's forced cooling. Adjustments are made only on TM1. Some special functions for controlling the cooling equipment are optional.



The cooling system's operating settings are further divided into several additional submenus, shown below.



5.8.1 CONF Submenu

It contains the general configuration parameters for forced cooling..



NGR - Total number of forced cooling groups

If only the TM1 Temperature Monitor is used, two output contacts will be available for cooling control, therefore the NGR parameter will allow an **adjustment range** of 1 to 2.



If TM1 and TM2 are used, four contacts will be available and the parameter will have an **adjustment range** of 1 to 4. In this case, it is possible to use the cooling control contacts of TM2 as redundancy for the contacts of TM1, simply by programming the number of NGR groups as 2.

Default value: 2.



HIS - Hysteresis

It is the difference between the starting and stopping temperatures of the fans and pumps.

It determines a temperature reduction value, below the cooling start temperature, to turn off the fans and pumps, in order to prevent them from being switched on and off repeatedly with small temperature variations.



Adjustment range: 0 to 9 °C; 1 °C steps.

Default value: 5.

HIC - Load hysteresis

This is the difference between the percentage of load required to start and stop the fans/pumps. It determines a reduction in the percentage of load, below the cooling start load, to shut down the fans/pumps, in order to prevent them from being switched on and off repeatedly with small variations in load.

This parameter will only be displayed if the Temperature Monitor has the optional **Pre-cooling** function.



Adjustment range: 0 to 9%, in 1% steps.

Default value: 5%.

EVH - Start hour for daily ventilator/pump activation

Adjusting the time (hour) at which the forced cooling units should be activated for the daily operation of the fans/pumps.

This parameter will only be displayed if the Temperature Monitor has the optional **Daily Cooling Activation** function.



Adjustment range: 0 to 23, in 1-hour steps.

Default value: 0.

EVM - Start minute for daily ventilator/pump activation

Adjusting the minute (in addition to the hour of the previous parameter) at which the forced cooling groups should be activated for the daily operation of the fans or pumps.

This parameter will only be displayed if the Temperature Monitor has the optional **Daily Cooling Activation** function.



Adjustment range: 0 to 59 minutes, in 1-minute steps.

Default value: 0.



TEV – Daily cooling runtime

Adjust the total daily time that the forced cooling units should remain activated for fan or pump exercise. If it is necessary to deactivate the Daily Cooling Activation function, simply program this parameter with the value zero.



This parameter will only be displayed if the Temperature Monitor has the optional **Daily Cooling Activation** function.

Adjustment range: 0 to 999 minutes, in 1-minute steps.

Default value: 0

5.8.2 ER1, ER2, ER3 and ER4 Submenus

The submenus ER1, ER2, ER3, and ER4 allow you to adjust the operating parameters of forced cooling stages 1 through 4, respectively. Each submenu essentially has the same parameters, as shown below.



RF1 / RF2 / RF3 / RF4 - Operating temperature of the 1st / 2nd / 3rd / 4th forced cooling stage

When the temperature of one of the transformer windings reaches the set value, one of the cooling groups registered in the corresponding cooling stage will be activated (selected as “YES” in the GR1, GR2, GR3 and GR4 parameters of each Stage).



Adjustment range: -55 to 200 °C, in 1 °C steps.

Default value: 65 / 75 / 85 / 95 °C

CV1 / CV2 / CV3 / CV4 - Percentage of load for activation of the 1st / 2nd / 3rd / 4th forced cooling stage

When the load percentage of one of the transformer windings reaches the set value, one of the cooling groups registered in the corresponding cooling stage will be activated (selected as “YES” in the GR1, GR2, GR3 and GR4 parameters of each stage).



Note: This parameter will only be displayed if the Temperature Monitor has the optional **Pre-cooling** function.

Adjustment range: 10 to 1000%, in 1% steps.

Default value: 70%

GR1 / GR2 / GR3 / GR4 - Inscription of cooling group 1 / 2 / 3 / 4 in the 1st / 2nd / 3rd / 4th forced cooling stage

Allows you to select whether the cooling group (1 / 2 / 3 / 4) will be included in the 1st / 2nd / 3rd / 4th Forced Cooling Stage, i.e., whether it can be considered available for use by the cooling stage when its operating temperature or percentage of load is reached.



Adjustment range: YES or NO.



Default value: -

5.9 DTC Menu (optional)

Allows access to parameters related to monitoring the on-load tap changer temperature differential. This monitoring function is optional; therefore, this submenu will only be displayed if the equipment has it. Adjustments are made only on TM1.



TTR - Selection of the transformer oil temperature sensor

Selection of the transformer oil temperature sensor, used for differential calculations.



Adjustment range:

- 1 - TM1 RTD Sensor A;
- 2 - TM1 RTD Sensor B;
- 3 - TM2 RTD Sensor A;
- 4 - TM2 RTD Sensor B;
- 5 - Top oil temperature.

Default value: 5.

TC1 - OLTC 1 temperature sensor selection

Selection of the tap changer temperature sensor, used for differential calculations.



Adjustment range:

- 0 - None (OLTC 1 temperature differential not used);
- 1 - TM1 RTD Sensor A;
- 2 - TM1 RTD Sensor B;
- 3 - TM2 RTD Sensor A;
- 4 - TM2 RTD Sensor B.

Default value: 2.

TC2 - OLTC 2 temperature sensor selection

Selection of the tap changer temperature sensor, used for differential calculations.



Adjustment range:

- 0 - None (OLTC 2 temperature differential not used);
- 1 - TM1 RTD Sensor A;
- 2 - TM1 RTD Sensor B;
- 3 - TM2 RTD Sensor A;
- 4 - TM2 RTD Sensor B.

Default value: 0.



TC3 - OLTC 3 temperature sensor selection

Selection of the commutator temperature sensor, used for differential calculations.

Adjustment range:

- 0 - None (OLTC 3 temperature differential not used);
- 1 - TM1 RTD Sensor A;
- 2 - TM1 RTD Sensor B;
- 3 - TM2 RTD Sensor A;
- 4 - TM2 RTD Sensor B.

Default value: 0.



CTF - Time constant for filtering

Time constant for filtering OLTC temperature differentials.

Adjustment range: 0 to 720 minutes, in 1-minute steps.

Default value: 180.



TAL - Time for alarms

Timing for triggering alarms based on OLTC temperature differentials.

Adjustment range: 0 to 240 minutes, in 1-minute steps.

Default value: 20.



MAA - Margin for automatic alarm adjustments

Safety margin added to the largest recorded temperature differential between the OLTC and transformer during the automatic learning period. Used to define the alarm threshold.

Adjustment range: 1 to 10 °C, in 1 °C increments.

Default value: 5.



TAA - Sampling time for automatic alarm adjustments

Total sampling time for automatic adjustment of alarms due to instantaneous and filtered temperature differentials.

Adjustment range: 1 to 720 hours, in 1-hour steps.

Default value: 336.



AAA - Automatic alarm adjustment

Allows you to start (ON) or stop (OFF) the automatic adjustment process for alarms due to instantaneous and filtered temperature differentials. When ON is selected, the countdown timer for automatic adjustment will begin, as programmed in the TAA parameter above.

Adjustment range: ON or OFF.

Default value: ON.



ADI - Alarm due to instantaneous differential

Value for alarm due to OLTC instantaneous temperature differential





(consultation or manual adjustment).

Adjustment range: -40 to +40 °C, in 0.1 °C steps.

Default value: 10.

ADF - Alarm due to filtered differential

Value for alarm due to OLTC filtered temperature differential.



Adjustment range: -40 to +40 °C, in 0.1 °C steps.

Default value: 10.

5.10 LOG Menu

Allows you to adjust the settings for recording measurements and events in the TM's mass memory. This submenu will only be displayed if the TM has this optional function. The mass memory is of the FIFO (First In First Out) type, meaning that when the memory is full, the oldest data begins to be overwritten by new data.



A new recording in memory can be initiated by a time interval, by a temperature variation greater than the set value, or by the occurrence of any event (alarms, shutdowns, or forced ventilation activations).



TLG - Time interval for recording to memory

Determines the time interval for a new recording to be made in mass storage, in minutes.



Adjustment range: 1 to 120 minutes, in 1-minute steps.

Default value: 60.

HLG - Log hysteresis

It sets a value for the variation in measured temperatures, in °C, which, if exceeded, causes the TM to perform a new recording in mass memory. This feature allows extending the time before older data in memory is overwritten, preventing recordings if measurements do not vary significantly.



Adjustment range: 1 to 20 °C, in 1 °C steps.

Default value: 5.

RST - Command to clear memory

Allows you to reset the mass storage, erasing all stored data. This process may take several seconds. During this time, the display will show RST / YES.



Adjustment range: NO or YES (Press the  key to confirm).

Default value: NO.





6 Commissioning for entry into service

Once the equipment has been installed, commissioning should follow these basic steps.

- ✓ Check the mechanical and electrical installations according to the recommendations in chapter **Error! Reference source not found.** of this manual. Also check the correctness of the electrical connections (for example, through continuity tests);
- ✓ Ensure that no secondary windings of current transformers (CTs) are open during the installation and operation of the temperature monitors. If the transformer is energized during the installation of TM1 and TM2, short-circuit and ground the CT secondary windings that will be connected to the equipment before any operation. After the installation is complete, thoroughly check these circuits before removing the short circuit from the secondary windings;
- ✓ If dielectric strength tests are performed on the wiring (applied voltage), disconnect the ground cables connected to terminals 13 of TM1 and TM2 to avoid destroying the surge protection devices inside the unit. These protections are internally connected between the input/output terminals and ground, clamping the voltage at approximately 300 V. Applying high voltages for an extended period (e.g., 2 kV for 1 minute) would destroy these protections;
- ✓ Reconnect the ground cables to terminals 13 of TM1 and TM2 if they were disconnected for applied voltage testing. Energize TM1 and TM2 with any voltage in the range of 38 to 265 Vac/Vdc 50/60Hz;
- ✓ Complete all parameter settings for TM1 and TM2. The completed parameter settings can be noted in the parameterization spreadsheet provided in the section **6.1**;
- ✓ Using a continuity tester, test the operation of the alarm, shutdown, and forced cooling contacts. The operation of the contacts can be forced, for example, by reducing their respective settings to values lower than the current measurements;
- ✓ Ensure that no operation of the contacts will interact with other systems during this phase. If necessary, isolate all control, alarm, and shutdown contacts by simply disconnecting the lower removable connector (terminals 1...A4);
- ✓ Connect a temperature calibrator, resistive decade box, or check the temperature of the Pt100 connected to each measurement input of the TM1, verifying that the measurements are correct;
- ✓ Inject AC current into the current measurement inputs of the TM1 and TM2 Temperature Monitors, verifying that the readings on the equipment's display screens are correct;
- ✓ Using a DC milliammeter, verify that the current loop outputs show values consistent with the corresponding temperature values;



- ✓ Reconnect any contacts that may have been isolated by reattaching the lower connector (terminals 1...A4).

6.1 Parameterization sheet

Below is the link and QR code for our Wiki and Support Center, where you can find a printable sheet with all TM parameters, designed to assist with the equipment configuration process.

Parameterization sheet:

sac.treetech.com.br/en/support/solutions/articles

Parameterization sheet







7 Troubleshooting

The TM1 and TM2 Temperature Monitor software constantly checks the integrity of its functions and the sensors and modules connected to it. Any anomaly detected is signaled through its fault contact. Messages will be displayed on the TMs' screen, assisting in the fault diagnosis process.

If you encounter difficulties or problems operating the system, we suggest consulting the possible causes and simple solutions presented in the following items. If this information is not sufficient to resolve the difficulty, please contact Treotech's technical support or your authorized representative.

7.1 The equipment displays self-diagnosis messages on the screen

The self-diagnosis function implemented in the TM1 and TM2 devices allows for the detection and diagnosis of any external problems or internal malfunctions, enabling the user to quickly identify and correct issues in most cases.

To access the TM's internal error memory, press and hold the  and  keys for a few seconds. All errors that have occurred will be displayed in overlay, and to clear this memory, simply press  and  for a few seconds.

Upon detecting a problem, the TM will display the abbreviation "ERR" on its upper display and the corresponding error code in hexadecimal on its lower display, as illustrated in the figure. Each fault is represented by one of the following values: 1, 2, 4, and 8. The value shown for the digit will be the sum of the values of all active alarms for that digit. If, for example, a certain digit is showing the number 3, this means that alarms 1 and 2 are active ($1 + 2 = 3$). If a digit shows the letter B, for example, alarms 1, 2, and 8 are currently active, since in hexadecimal numbers $B = 1 + 2 + 8$.

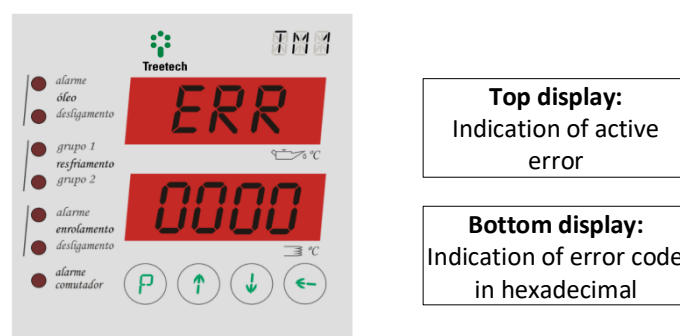

Figure 27 - Indications of self-diagnosis

To check the procedure in case of self-diagnosis and possible errors generated by TM1/TM2, follow the instructions by clicking the link below or scanning the QR code to be redirected to Treotech's Customer Service.



Self-diagnoses:



FAQs:





8 Technical data and type tests

8.1 Technical data

Hardware	Range/Description
Supply voltage:	38 to 265 Vac/Vdc 50/60 Hz
Maximum consumption:	< 8 W
Operating temperature:	-40...+85 °C
Protection rating:	IP20
Connections - Except CT inputs:	0.3...2.5 mm ² , 22...12 AWG
Connections - CT inputs:	One or two 1.5 to 2.5 mm ² , 16 to 12 AWG cables using safety eye terminals
Mounting:	Recessed panel mounting
Analog outputs:	2 (with common positive) per device (TM1 or TM2)
Maximum error:	0.5% of full scale
Options (selectable) and maximum load:	0...1 mA, 10 kΩ 0...5 mA, 2 kΩ 0...10 mA, 1 kΩ 0...20 mA, 500 Ω 4...20 mA, 500 Ω
Relay outputs:	Potential-free contacts
Type and functions (standard):	5NO (alarms/shutdown) + 3NC (2 RF + 1 self-diagnosis) per device (TM1 or TM2)
Maximum switching power:	70 W (dc) / 220 VA (ac) non-inductive
Maximum switching voltage:	250 Vac / Vdc
Maximum conduction current:	5 A
Maximum breaking current:	5 A, 250 Vac, cosφ = 1 5 A, 30 Vdc, 0 ms 0.175 A, 125 Vdc, DC13 or L/R = 40 ms 0.500 A, 125 Vdc, DC13 or L/R = 40 ms (<i>with reverse bias diode or surge suppressor diode</i>)
Direct temperature measurements (e.g., oil, ambient temperature, OLTC, etc.):	Inputs for RTD sensors with continuous self-calibration
Sensor:	Pt100Ω at 0 °C
Measurement range:	-55...200 °C
Maximum error at 20 °C:	0.4% of full scale
Deviation due to temperature variation:	20 ppm/°C
Connection options for each device:	2 three-wire sensors, or 1 four-wire sensor, or 1 three-wire sensor
Winding temperature measurement:	Calculated
Applied mathematical models:	ABNT NBR 5416 (1997), IEEE C57.91 (1995) IEC 60076-7 (2005)
AC current measurement inputs:	Direct measurement or with external clip-on CT scanner
Operating range:	0...10 A
Maximum error at 20 °C:	0.5% of full scale (1% with clip-on CT scanner)
Deviation due to temperature variation:	50 ppm/°C



Communication protocols (<i>Access via TM1</i>):	Modbus (standard) / DNP3 level 1 (optional)
Serial communication ports:	1 RS-485 for TM1/TM2 or IRIG-B interconnection 1 selectable RS-485 / RS-232 for supervisory system (TM1 only)
Mass storage (optional):	
Recording interval:	1 to 120 minutes
Temperature variation for recording:	1 to 20 °C
Capacity	
TM1 without OLTC Temp. Differential:	1465 records
TM1 with OLTC Temp. Differential:	948 records
TM1+TM2 without OLTC Temp. Differential:	848 records
TM1+TM2 with OLTC Temp. Differential:	645 records



8.2 Type tests

Hardware	Range/Description
Immunity to surges (IEC 60255-22-5)	
Phase-neutral surges:	1 kV, 5 per polarity (+/-)
Phase-to-ground and neutral-to-ground surges:	2 kV, 5 per polarity (+/-)
Immunity to electrical transients (IEC 60255-22-1 and IEEE C37.90.1)	
Peak value 1st cycle:	2.5 kV
Frequency:	1.1 MHz
Time and repetition rate:	2 seconds, 400 bursts/sec.
50% decay:	5 cycles
Voltage impulse (IEC 60255-5)	
Waveform:	1.2 / 50 sec.
Amplitude and energy:	5 kV
Number of pulses:	3 negative and 3 positive, 5s interval
Applied voltage (IEC 60255-5)	
Power-frequency withstand voltage	2 kV 60 Hz 1 min. against ground
Immunity to radiated electromagnetic fields (IEC 61000-4-3 / IEC60255-22-3)	
Frequency:	26 to 1000 MHz
Field strength:	10 V/m
Immunity to conducted electromagnetic interference (IEC 60255-22-6)	
Frequency:	0.15 to 80 MHz
Field strength:	10 V/m
Electrostatic discharges (IEC 60255-22- and IEEE C37.90.3)	
Air mode:	8 kV, ten discharges per polarity
Contact mode:	6 kV, ten discharges per polarity
Immunity to fast electrical transients (IEC60255-22-4 and IEEE C37.90.1)	
Test of power supply, inputs, and outputs:	4 kV
Test of serial communication:	2 kV
Climate test (IEC 60068-2-14)	
Temperature range:	-40 to +85 °C
Total test time:	96 hours
Vibration response (IEC 60255-21-1)	
Application Method:	3 axes (X, Y and Z), sinusoidal
Amplitude:	0.075 mm from 10 to 58 Hz 1G from 58 to 150 Hz
Duration:	8 min/axis
Vibration resistance (IEC 60255-21-1)	
Application Method:	3 axes (X, Y, and Z), sinusoidal
Frequency:	10 to 150 Hz
Intensity:	2 G
Duration:	160 min/axis
Short-duration overload (IEEE C57.109-1993 and NBR 8145/83):	AC current measurement inputs



9 Specification for order

The TM1 and TM2 Temperature Monitors are universal devices, with most of their features selectable through their programming menus. These adjustments can be made directly on their front panel or via the RS-232 or RS-485 serial communication ports. The power input is universal (38 to 265 Vac/Vdc 50/60 Hz).

Therefore, when ordering the standard device, you only need to provide the following information:

1. Product name

Temperature Monitor - TM1 or Temperature Monitor - TM2.

2. Quantity

The number of units.

3. CT connection type:

a. Internal CT

Standard for direct connection of CT (0 to 10 A).

b. External CT

An external CT with a sectionable core is required (accessories not included must be specified separately).

4. Relay contact configuration

Some TM relays can be configured with NO (Normally Open) or NC (Normally Closed) contacts. If you require a specific configuration, please specify it in your order according to the following table.

DEFAULT	CONFIGURATION	TM1 RELAYS	TM2 RELAYS
NA	NO or NC	Alarm due to oil	Alarm due to winding 2
NA	✘	Oil shutdown	Winding 2 shutdown
NF	NO or NC	Forced cooling 1	Forced cooling 1
NF	NO or NC	Forced cooling 2	Forced cooling 2
NA	NO or NC	Alarm due to winding 1	Alarm due to winding 3
NA	✘	Winding 1 shutdown	Winding 3 shutdown
NA	NO or NC	Programmable	Programmable
NF	NO or NC	Failure	Failure

* If no configuration is specified, the equipment will be shipped with the default configuration.

CAPTION	
NO or NC	Configurable
✘	Not configurable



Observation:

The shutdown relays are **NOT** configurable.

5. Optional items

More than one optional item can be specified for the same equipment.

- DNP3 - DNP3 protocol (formerly optional 1)
- PCOL - Pre-cooling (formerly optional 2)
- FEXC – Daily fan/pump activation (formerly optional 3)
- OLTD - OLTC temperature differential (formerly optional 4)

Note: The TM2 Temperature Monitor must work in conjunction with the TM1 Temperature Monitor and cannot be used separately.



Treotech

Treotech Tecnologia
Rua José Alvim, 112, Centro
Cep 12940-750 – Atibaia/SP
+55 11 2410 1190
www.treotech.com.br