



Treetech®



# Product Manual

[treetech.com.br](http://treetech.com.br)



# Contents

1.	Foreword .....	1
1.1.	Legal information .....	1
1.1.1.	Disclaimer .....	1
1.2.	Presentation .....	1
1.3.	Typographical conventions .....	1
1.4.	General and safety information .....	1
1.4.1.	Safety symbols .....	2
1.4.2.	General symbols .....	2
1.4.3.	Minimum profile recommended for SDV operator and maintainer .....	2
1.4.4.	Environmental and voltage conditions required to installation and operation .....	3
1.4.5.	Test and installation instructions .....	4
1.4.6.	Cleaning and decontamination instructions .....	4
1.4.7.	Inspection and maintenance instructions .....	5
1.5.	Customer service .....	6
1.6.	Warranty term .....	8
2.	Introduction .....	9
2.1.	Intended use .....	9
2.2.	Features .....	10
2.3.	Functions .....	11
2.4.	Input, output and communication terminals .....	14
2.4.1.	Inputs .....	14
2.4.2.	Outputs .....	14
2.4.3.	Communication .....	14
3.	Design and installation .....	17
3.1.	Installation and removal of terminals .....	17
3.2.	Mechanical installation .....	17
3.2.1.	Standard DIN rail installation .....	17
3.2.2.	Built-in panel installation .....	19
3.3.	Electrical installation .....	20
3.3.1.	Input terminals .....	22
3.3.1.1	Power and grounding .....	22
3.3.1.2	Current inputs .....	22
3.3.1.3	Temperature sensors .....	25
3.3.1.4	Voltage input .....	26
3.3.1.5	Tap measurement input .....	27
3.3.1.5.1	<b>Potentiometric transmitter .....</b>	<b>27</b>



<b>3.3.1.5.2</b>	<b>BCD digital input</b> .....	31
<b>3.3.1.5.3</b>	<b>Analog signal (mA)</b> .....	32
3.3.1.6	Wet contact inputs .....	32
3.3.2.	Output terminals.....	34
3.3.3.	Communication ports.....	36
3.3.3.1	Precautions when installing the RS-485 network.....	37
<b>3.3.3.1.1</b>	<b>Communication with the data acquisition system</b> .....	37
<b>3.3.3.1.2</b>	<b>Parallelism communication</b> .....	37
4.	Operation.....	39
4.1.	Signaling LEDs.....	39
4.2.	Key function .....	40
4.3.	Contrast adjustment .....	40
4.4.	Query screens.....	41
4.5.	General screen .....	41
4.5.1.	Advanced temperature query .....	43
4.5.1.1	OLTC temperature differential (OLTD).....	45
4.5.1.2	Cooling group .....	46
4.5.1.3	Insulation aging .....	47
4.5.2.	Advanced regulation query .....	48
4.5.3.	General advanced query .....	50
4.6.	Warnings.....	52
4.7.	SDV firmware, bootloader and other information .....	54
5.	Website.....	56
5.1.	Navigation .....	56
5.2.	Log in.....	58
5.3.	Online.....	60
5.3.1.	Data status.....	60
5.3.2.	Data arrangement.....	61
5.4.	Parameterization.....	62
5.4.1.	General .....	63
5.4.1.1.	Basic.....	63
5.4.1.2.	Commands .....	65
5.4.2.	Transformer .....	65
5.4.2.1.	Basic.....	65
5.4.2.2.	Winding CTS' Relation.....	67
5.4.2.3.	Temperature .....	67
<b>5.4.2.3.1.</b>	<b>Cooling CTS' Relation</b> .....	67
<b>5.4.2.3.2.</b>	<b>Thermal image CTS' Relation</b> .....	68



- 5.4.2.4. Regulation ..... 69
  - 5.4.2.4.1. PT/Line CT ratio**..... 69
- 5.4.3. Temperature ..... 70
  - 5.4.3.1. Basic ..... 70
  - 5.4.3.2. Alarms ..... 72
  - 5.4.3.3. Winding ..... 73
    - 5.4.3.3.1. Winding 'x'** ..... 74
  - 5.4.3.4. Cooling ..... 76
    - 5.4.3.4.1. Configuration** ..... 76
    - 5.4.3.4.2. Pre-cooling by load** ..... 79
    - 5.4.3.4.3. Cooling monitoring** ..... 80
    - 5.4.3.4.4. Fan exercise** ..... 84
  - 5.4.3.5. OLTC temperature differential ..... 85
    - 5.4.3.5.1. Configuration** ..... 85
    - 5.4.3.5.2. Alarms**..... 86
    - 5.4.3.5.3. Commands**..... 87
  - 5.4.3.6. Aging ..... 88
    - 5.4.3.6.1. Configuration** ..... 89
    - 5.4.3.6.2. Alarms**..... 91
  - 5.4.3.7. Commands ..... 92
- 5.4.4. Regulation..... 93
  - 5.4.4.1. Basic ..... 93
  - 5.4.4.2. Alarms ..... 95
    - 5.4.4.2.1. Parameters** ..... 95
    - 5.4.4.2.2. Values** ..... 96
  - 5.4.4.3. Regulation sets ..... 99
    - 5.4.4.3.1. Configuration** ..... 99
    - 5.4.4.3.2. Set 'x'** ..... 99
  - 5.4.4.4. OLTC position measurement ..... 105
    - 5.4.4.4.1. Configuration** ..... 106
    - 5.4.4.4.2. Calibration** ..... 110
  - 5.4.4.5. OLTC check ..... 111
  - 5.4.4.6. OLTC maintenance ..... 112
    - 5.4.4.6.1. Initial configuration**..... 113
    - 5.4.4.6.2. Parameterization** ..... 114
    - 5.4.4.6.3. Alarms**..... 116
  - 5.4.4.7. Wet contacts ..... 118
  - 5.4.4.8. Commands ..... 119



5.4.5.	Relays .....	121
5.4.5.1.	General.....	121
5.4.5.2.	Temperature .....	122
5.4.5.3.	Regulation .....	126
5.5.	Configuration.....	129
5.5.1.	Output interfaces .....	129
5.5.2.	Configuring communication .....	131
5.5.3.	Network.....	132
5.5.3.1.	Independent ports mode .....	132
5.5.3.2.	Bridge port mode.....	132
5.6.	Logs .....	133
5.7.	About .....	134
6.	Troubleshooting.....	135
6.1.	Self-diagnosis.....	135
6.2.	Alarms .....	143
6.3.	Alarm memories and self-diagnosis .....	145
7.	Commissioning for entry into service.....	146
7.1.	General commissioning guidelines.....	146
7.2.	Commissioning guidelines for regulation functionality .....	146
7.3.	Commissioning guidelines for temperature functionality .....	147
8.	Technical data and type tests .....	148
8.1.	Technical data .....	148
8.2.	Type tests .....	151
9.	Order specification.....	153



# Illustrations

Figure 1 - System topology .....	9
Figure 2 - Graph representing the OLTC check limit .....	13
Figure 3 - FOFO Model .....	15
Figure 4 - FOSR Model.....	15
Figure 5 - RJ45 Model.....	16
Figure 6 - Terminal with screws.....	17
Figure 7 - SDV dimensions (DIN Rail) .....	18
Figure 8 - SDV dimensions (Panel).....	19
Figure 9 - SDV connection diagram.....	21
Figure 10 - Connection for single-phase transformer, 0° phase shift .....	23
Figure 11 - Connection for phase-neutral PT, 0° phase shift.....	23
Figure 12 - Connection for phase-to-phase PT, 0° phase shift .....	24
Figure 13 - Connection for phase-to-phase PT, 150° phase shift .....	24
Figure 14 - Connection for phase-to-phase PT, 210° phase shift .....	24
Figure 15 - Connection for phase-to-phase PT, 270° phase shift.....	25
Figure 16 - Connection of the interconnection shield between RTD sensors and the SDV .....	26
Figure 17 - Connecting the shielding of the TAP measuring cables.....	27
Figure 18 - Configuration of the potentiometric transmitter resistors in the intermediate positions of the OLTC .....	29
Figure 19 - Illustration of intermediate taps.....	30
Figure 20 - Central tap indication .....	31
Figure 21 - BCD digital input.....	31
Figure 22 - Tap position measurement by analog signal.....	32
Figure 23 - Wet contact connection .....	33
Figure 24 - RS-485 serial communication shield connection and grounding .....	37
Figure 25 - SDV interconnection as a parallelism concentrator .....	38
Figure 26 - Arrangement and function of LEDs .....	39
Figure 27 - SDV front LEDs.....	40
Figure 28 - SDV contrast adjustment .....	41
Figure 29 - Display indicating self-diagnosis.....	52
Figure 30 - Command to access equipment information.....	54
Figure 31 - Display indicating system functionality .....	54
Figure 32 - Display indicating system version.....	54
Figure 33 - Display indicating application version .....	54
Figure 34 - Display indicating firmware and bootloader version and release.....	55
Figure 35 - Display indicating serial number .....	55
Figure 36 - Language tab .....	56
Figure 37 - Information icon .....	57
Figure 38 - Login screen .....	58
Figure 39 - User tab.....	58
Figure 40 - Incorrect username or password .....	59
Figure 41 - Time limit .....	59
Figure 42 - Online section.....	60
Figure 43 - View mode icons .....	60
Figure 44 - Data status .....	60
Figure 45 - Information board .....	61
Figure 46 - Horizontal tabs of the Online tab .....	61
Figure 47 - Configuration tabs .....	62
Figure 48 - Submit button .....	62



Figure 49 - Value outside the determined range.....	62
Figure 50 - General → Basic.....	63
Figure 51 - Reset to default value button .....	63
Figure 52 - Confirmation message.....	63
Figure 53 - General → Commands .....	65
Figure 54 - Transformer → Basic.....	65
Figure 55 - Transformer → Winding CTS' Relation.....	67
Figure 56 - Temperature → Cooling CTS' Relation.....	67
Figure 57 - Temperature → Thermal Image CTS' Relation .....	68
Figure 58 - Regulation → PT/Line CT ratio.....	69
Figure 59 - Temperature → Basic.....	70
Figure 60 - Temperature → Alarms.....	72
Figure 61 - Temperature → Winding 'x' .....	74
Figure 62 - Cooling → Configuration .....	76
Figure 63 - Group registration table .....	78
Figure 64 - Temperature → Pre-cooling by load .....	79
Figure 65 - Cooling monitoring → Configuration .....	80
Figure 66 - Alarms → Parameterization.....	81
Figure 67 - Alarms → Values.....	83
Figure 68 – Fan exercise.....	84
Figure 69 - OLTC temperature differential → Configuration .....	85
Figure 70 - OLTC temperature differential → Alarms.....	86
Figure 71 - OLTC temperature differential → Commands.....	87
Figure 72 - Aging → Configuration .....	89
Figure 73 - Aging → Alarms.....	91
Figure 74 - Cooling → Commands .....	92
Figure 75 - Regulation → Basic.....	93
Figure 76 - Alarms → Parameters .....	95
Figure 77 - Alarms → Values .....	96
Figure 78 - Regulation sets → Configuration .....	99
Figure 79 - Regulation sets .....	100
Figure 80 - OLTC position measurement → Configuration.....	106
Figure 81 - Selection of potentiometric transmitter measurement .....	108
Figure 82 - mA current loop measurement selection.....	109
Figure 83 - OLTC position measurement → Calibration .....	110
Figure 84 - Regulation → OLTC check.....	112
Figure 85 - OLTC maintenance → Initial configuration.....	113
Figure 86 - OLTC maintenance → Parameterization .....	114
Figure 87 - OLTC maintenance → Alarms .....	116



Figure 88 - Wet contacts .....	118
Figure 89 - Commands .....	119
Figure 90 - Relays → General .....	121
Figure 91 - Activation by the general equipment status .....	121
Figure 92 - Relays → Temperature .....	122
Figure 93 - Table of Configuration of relays for oil and windings.....	122
Figure 94 - Table of configuration of relays for cooling monitoring 1-2 .....	123
Figure 95 - Table of configuration of relays for cooling monitoring 3-4 .....	123
Figure 96 - Table of configuration of relays for OLTC temperature differential .....	124
Figure 97 - Table of configuration of relays for aging .....	125
Figure 98 - Relays → Regulation.....	126
Figure 99 - Table of configuration of relays for general regulation warnings.....	126
Figure 100 - Table of configuration of relays for OLTC check.....	127
Figure 101 - Table of configuration of relays for OLTC maintenance .....	127
Figure 102 - Configuration Tab .....	129
Figure 103 - Description of configurations .....	129
Figure 104 - Configuration section → Output Interfaces.....	129
Figure 105 - Configuration area .....	131
Figure 106 - Configuration from output.....	131
Figure 107 - Configurations → Independent ports mode.....	132
Figure 108 - Configurations → Bridge port mode .....	133
Figure 109 - System logs.....	133
Figure 110 - “About” section .....	134
Figure 111 - Self-diagnosis indication .....	135
Figure 112 - Alarms .....	143
Figure 113 - Alarm memory and self-diagnosis .....	145



# Tables

Table 1 - Operation conditions .....	3
Table 2 - SDV power and ground .....	22
Table 3 - Current inputs .....	22
Table 4 - Input for Pt100.....	25
Table 5 - Voltage input .....	26
Table 6 - Tap measurement by potentiometric transmitter .....	27
Table 7 - Maximum length for tap measuring cable gauges .....	27
Table 8 - Resistance of the cursor indicating the TAP position .....	28
Table 9 - Tap measurement by BCD digital input .....	31
Table 10 - Tap measurement by analog signal (mA).....	32
Table 11 - Wet contact inputs .....	32
Table 12 - Input state .....	33
Table 13 - SDV output terminals.....	34
Table 14 - SDV Communication Terminals .....	36
Table 15 - SDV key functions .....	40
Table 16 - SDV query screens.....	41
Table 17 - Temperature submenu information .....	43
Table 18 - OLTD Submenu .....	45
Table 19 - Cooling group submenu .....	46
Table 20 - Insulation aging submenu .....	47
Table 21 - Regulation submenu .....	48
Table 22 - General submenu.....	50
Table 23 - Winding exponent - IEC.....	75
Table 24 - Winding exponent - ABNT.....	75
Table 25 - Self-diagnosis panel 1 .....	136
Table 26 - Self-diagnosis panel 2 .....	138
Table 27 - Self-diagnosis panel 3 .....	140
Table 28 - Alarm panel 1 .....	143
Table 29 - Alarm panel 2 .....	144
Table 30 - Alarm panel 3 .....	144
Table 31 - Technical data.....	148
Table 32 - Type tests .....	151



# 1. Foreword

## 1.1. Legal information

**The information contained in this document is subject to change without notice.**

This document belongs to Treetech Tecnologia Ltda. and may neither be copied, transferred to third parties nor used without express authorization, in terms of Brazilian law 9.610/98.

### 1.1.1. Disclaimer

Treetech Tecnologia reserves the right to make changes without prior notice in all products, circuits and functionalities described herein with the aim of improving their reliability, function or design. Treetech Tecnologia does not assume any liability resulting from application or use of any product or circuit described in here and does not transmit any licenses or patents under its rights, not even third party rights.

Treetech Tecnologia may own patent or other types of registrations and intellectual property rights described in the content of this document. Possession of this document by any person or entity does not give such person or entity any right over these patents or registrations.

## 1.2. Presentation

This manual presents all the recommendations and instructions for installation, operation and maintenance of the Smart Device for Voltage Regulation - SDV.

## 1.3. Typographical conventions

Throughout this text, the following typographical conventions were adopted:

**Bold:** Symbols, terms and words that are in bold have greater contextual importance. Therefore, pay attention to these terms.

*Italics:* Terms in foreign language, alternative or with their use outside the formal situation are written in italics.

Underlined: References to external documents.

## 1.4. General and safety information

This section presents relevant aspects of safety, installation and maintenance of the SDV.



### 1.4.1. Safety symbols

This manual uses three types of risk classification, as shown below:



**Warning:**

This symbol is used to highlight certain observations, alerting the user to a potentially dangerous operational or maintenance procedure that requires greater care when carried out. Minor or moderate injuries and equipment damage may occur.



**Caution:**

This symbol is used to alert the user of a potentially dangerous operating or maintenance procedure, which demands extreme caution in its conduction. There may occur serious injuries or even death. Possible damages to the equipment may be irreparable.



**Risk of electric shock:**

This symbol is used to alert the user of an operating or maintenance procedure that may result in electric shock if not strictly overseen. There may be minor, moderate, serious injuries or death.

### 1.4.2. General symbols

This manual uses the following general symbols:



**Important**

This symbol is used to highlight important information.



**Tip**

his symbol represents instructions that facilitate the use or access to functions in the SDV.

### 1.4.3. Minimum profile recommended for SDV operator and maintainer

Installation, maintenance and operation of equipment in electric power substations require special cares and, therefore, all recommendations of this manual, applicable standards, safety procedures, safe work practices and good judgment must be used during all handling stages of the Smart Device for Voltage Regulation - SDV.



Only authorized and trained staff – operators and maintainers – should handle this equipment.

To handle the SDV, the operator should:

- ✓ Be trained and authorized to operate, ground, turn on and off the SDV, following maintenance procedures in accordance with established safety practices, which are the sole responsibility of the SDV operator and maintainer;
- ✓ Be trained in the use of PPEs, CPEs and first-aid;
- ✓ Be trained in the working principles of the SDV, as well as its configuration;
- ✓ Follow regulatory recommendations regarding interventions in any type of equipment included in an electric power system.

#### 1.4.4. Environmental and voltage conditions required to installation and operation

The table below lists important information on the environmental and voltage requirements.

Table 1 - Operation conditions

Condition	Range/description
Supply voltage	85 ~ 250 Vac/Vdc
Application	Equipment for sheltered use in substations, industrial and similar environments
Indoor/outdoor use	Indoor use
Altitude* (IEC EN 61010-1)	1000 m
Protection level (IEC 60529)	IP20
<b>Temperature (IEC EN 61010-1)</b>	
Operation	-40...+85 °C
Storage	-50...+95 °C
<b>Relative humidity (IEC EN 61010-1)</b>	
Operation	5...90% - Non-condensed
Storage	5...90% - Non-condensed
Overvoltage (IEC EN 61010-1)	Category II
Degree of pollution (IEC EN 61010-1)	Degree 2
Atmospheric pressure ** (IEC EN 61010-1)	80...110 kPa

\* Altitudes above 2000 m already have successful applications.

\*\* Pressures below 80 kPa already have successful applications.



### 1.4.5. Test and installation instructions

This manual must be available to those responsible for installation and maintenance and for users of the Smart Device for Voltage Regulation – SDV.

To ensure user safety, equipment protection and correct operation, the following minimum precautions must be followed during the installation and maintenance of the SDV.

1. Read this manual carefully before installing, operating, and maintaining the SDV. Errors in the installation, maintenance, or adjustments of the SDV may cause inadvertent alarms or failure to issue appropriate alarms;
2. The installation, adjustments and operation of the SDV must be carried out by trained personnel familiar with power transformers, control devices and command circuits of substation equipment;
3. Special attention must be given to the installation of the SDV, including the type and gauge of the cables, installation location and commissioning, including the correct parameterization of the equipment.



The SDV must be installed in a sheltered environment (a panel without doors in a control room or a closed panel, in cases of outdoor installation), which does not exceed the temperature and humidity specified for the equipment.



Do not install the SDV near heat sources such as heating resistors, incandescent lamps, and high-power devices or devices with heat sinks. It is also not recommended to install it near ventilation openings or where it could be hit by forced airflow, such as the outlet or inlet of cooling fans or forced ventilation ducts.

### 1.4.6. Cleaning and decontamination instructions

Be careful when cleaning the SDV. Use **only** a damp cloth with soap or detergent diluted in water to clean the case, front panel, or any other part of the device. Do not use abrasive materials, polishes, or harsh chemical solvents (such as alcohol or acetone) on any of its surfaces.



Turn off and unplug the equipment before cleaning any parts of it.



### 1.4.7. Inspection and maintenance instructions

For inspection and maintenance of the SDV, the following observations must be followed:



Do not open your equipment. There are no user-serviceable parts. This should be done by Treotech technical support or certified technicians.  
This equipment is completely maintenance-free, and visual and operational inspections, whether periodic or not, can be performed by the user. These inspections are not mandatory.



Opening the SDV at any time will void the product warranty. In cases of improper opening, Treotech cannot guarantee its proper operation, regardless of whether the warranty period has expired or not.



All parts of this equipment must be supplied by Treotech, or one of its accredited suppliers, in accordance with its specifications. If the user wishes to acquire them in another way, they must strictly follow Treotech specifications for this. This way, performance and safety for the user and the equipment will not be compromised. If these specifications are not followed, the user and the equipment may be exposed to unforeseen risks.



## 1.5. Customer service

Do you already know our online customer service platform?

[CS](#)



The Customer Service page provides a quick and direct communication channel with our support team. Get answers to questions, resolve issues, and stay up-to-date on your Treotech product application. The Treotech knowledge base is also available, including catalogs, manuals, application notes, frequently asked questions, and more.



In some cases, it will be necessary to send the equipment to Treotech Technical Support. Our Customer Service department provides the entire procedure and necessary contact information.



## 1.6. Warranty term

The Smart Device for Voltage Regulation - SDV will be guaranteed by Treotech for a period of 2 (two) years, counting from the date of purchase, exclusively against any manufacturing defects or quality defects that make it unsuitable for regular use.

The warranty will not cover damage suffered by the product as a result of accidents, abuse, incorrect handling, incorrect installation and application, inadequate testing or in the event of the warranty seal being broken.

Any need for technical assistance must be communicated to Treotech or its authorized representative, presenting the equipment accompanied by proof of purchase.

No express or implied warranties other than those cited above are provided by Treotech. Treotech does not provide any guarantee of suitability of the SPS for a particular application.

Seller shall not be liable for any type of damage to property or for any losses or damages arising out of, connected with, or resulting from the purchase of the equipment, the performance thereof, or any service possibly provided in conjunction with the SDV.

Under no circumstances will the seller be held responsible for losses incurred, including, but not limited to: loss of profits or income, inability to use the SDV or any associated equipment, capital costs, costs of purchased energy, costs of equipment, installations or substitute services, downtime costs, claims from customers or employees of the buyer, regardless of whether said damages, claims or losses are based on contract, warranty, negligence, tort or otherwise. Under no circumstances will the seller be held liable for any personal injury of any kind.



## 2. Introduction

### 2.1. Intended use



Figure 1 - System topology

The Smart Device for Voltage Regulation – SDV, is a device that unites the main functionalities of a voltage regulator relay combined with control with thermal protection and parallelism concentrator COMM-04 by Treotech.

Voltage quality and thermal management of electrical equipment, such as transformers, are essential for their safe operation, allowing these assets to get the most out of their investment without jeopardizing their useful life.

During its operation, the SDV aims to maintain the quality of the voltage in the load, that is, within a determined range of values, programmed by the user.

Based on readings of the insulating oil temperature and one or more load currents of the transformer, the SDV performs calculations (thermal imaging) of the temperature of one or more windings and acts on the temperature management of the machine (ANSI functions 26 and 49).

Finally, Treotech's SDV was specially designed to integrate harmoniously and completely with any product that supports the Modbus®, DNP3 and IEC 61850 protocols.



## 2.2. Features

### Robust hardware

The SDV design exceeds EMC (Electromagnetic Compatibility) standards to withstand harsh substation electromagnetic conditions and operating temperatures from -40 to 85°C.

### Self-diagnosis

Self-diagnosis relay, to indicate internal faults and integration faults with peripheral equipment, such as other sensors.

### Multimeter function

Indications of voltages in the transformer and in the load, voltage deviation, current, active, reactive and apparent powers, load percentage, power factor and frequency.

### International standards met

IEEE C57.91:2011 and IEC 60076-7:2018 (international); ABNT NBR 5416:1997 and ABNT NBR 5356-7:2017 (Brazilian). UL certification is currently in the homologation process and applies only to the SDV model in the FOFO version.

APPROVALS			
	Model	Description	File number
UL			
	FOFO	2 Ethernet fiber optic	E542165

### Embedded operating system

The SDV has an embedded operating system customized by Treotech. This ensures greater stability and reliability of the product's firmware operation.

### Access security

To ensure access and data security, the SDV works with profiles of different access levels for operation, configuration and remote administration.

### Remote update

Through the web interface, the firmware update process becomes extremely simple and intuitive.

### Communication log download

SDV makes available in its interface the download of the communication log to facilitate network diagnosis.

### Expertise in embedded systems

Treotech has experts in embedded operating systems with extensive experience in the field. This knowledge has been incorporated into the SDV, making it an extremely secure and stable product, while remaining easy to operate.



## 2.3. Functions

### Pre-cooling

Extends insulation life by activating cooling units when user-selected load levels are reached. Taking advantage of the oil's high thermal inertia, forced cooling is activated before the temperature rises excessively, reducing winding exposure to high temperatures and increasing insulation life. These are user-programmable:

- ✓ Loading percentage for individual activation of each forced cooling stage;
- ✓ Hysteresis to turn off forced cooling stages when load decreases.

### OLTC temperature differential

This function allows the transformer oil temperature to be compared with that of the tap changer, so that abnormal temperature differentials can be detected and maintenance crews can be alerted to developing tap changer faults.

As the temperature differential is subject to the influence of external variables, monitoring is carried out in two distinct modes, in order to increase diagnostic efficiency and avoid false alarms:

- ✓ Instantaneous Differential Monitoring - Provides alarms with rapid response in case of high intensity defects, even if of short duration;
- ✓ Filtered Differential Monitoring - By subjecting the Instantaneous Differential to a low-pass filter, it is possible to detect trends in the evolution of the differential that indicate small-intensity permanent defects.

### OLTC position measurement

An input for measuring the OLTC position using a potentiometric transmitter, with cable resistance compensation and error detection. Associated functions:

- ✓ Programming the current output for remote tap indication;
- ✓ Manual command of the local OLTC (front panel), via serial or Ethernet communication;
- ✓ Limiting the OLTC excursion range (minimum and maximum taps allowed) and memorizing the minimum and maximum positions reached by the SDV since the last reset.



## Tap changer maintenance assistant

This optional item extends the functionality of the SDV, e.g.:

- ✓ OLTC operations counter, with maintenance warning by number of operations;
- ✓ Integration of switched current squared, with maintenance warning due to high  $I^2$  summation;
- ✓ Estimated remaining time for maintenance;
- ✓ Maintenance alarms are issued with programmable advance notice.

## Verifying the success of the tap change

This function allows the SDV to verify the success of the tap changing by means of voltage changes after the regulation command (increase/decrease voltage), without the need to measure the tap position.

The algorithm applied to this verification method compares the initial voltage levels with the voltage levels after the tap change command. Once the difference between the measured voltages is less than the deviation, the OLTC is inactive, generating tap changing failure warnings.

In some cases, more than one tap change is required to return the voltage to acceptable limits. To avoid error indication on the first tap change, the "Limit of attempts to generate a regulation failure alarm on the tap changer" parameter is used. This parameter defines the limit number of voltage rereadings to cover subsequent tap changes. Only after performing the verification up to the established limit, if the voltage difference remains below the deviation, will the alarms be issued.

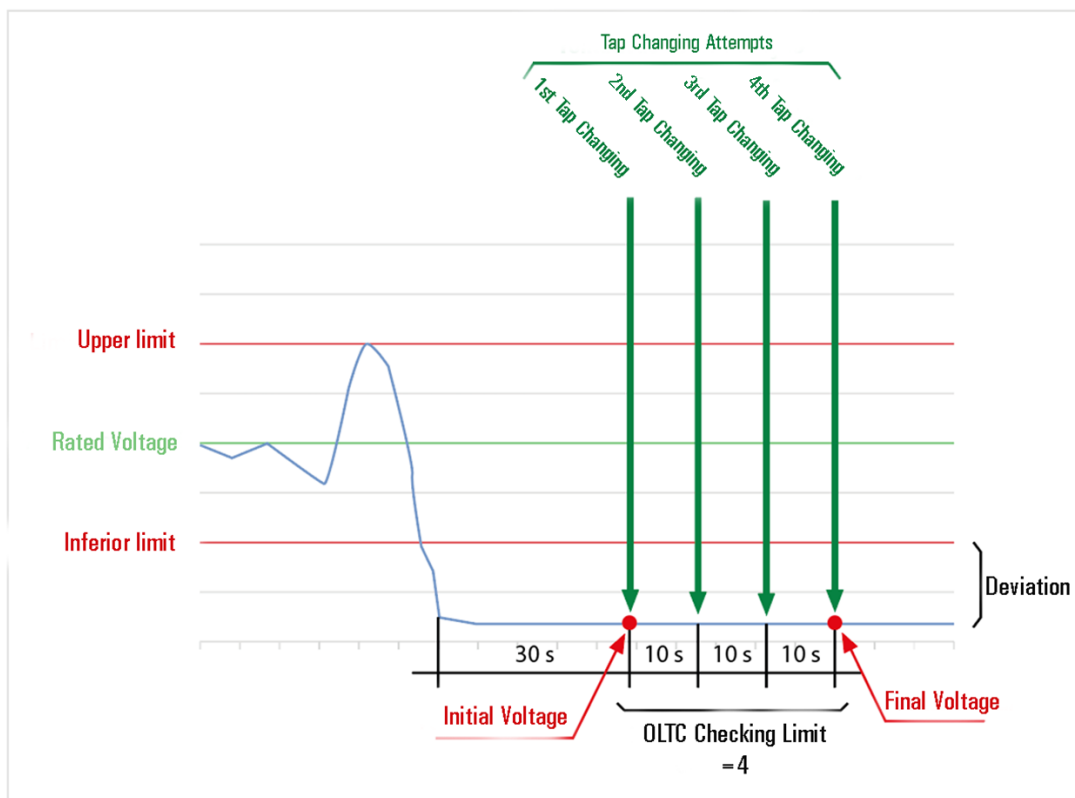

Figure 2 - Graph representing the OLTC check limit

## Insulation aging monitoring

This function performs online monitoring of the loss of life of the winding insulation, providing important information for the diagnosis and prognosis of the equipment condition:

- ✓ Ongoing percentage of useful life remaining, from 100% (new insulation) to 0% (end of insulation life);
- ✓ Average insulation life loss rate, in % per day, calculated over a user-selectable period;
- ✓ Extrapolation of the remaining lifespan for the insulation, calculated based on the variables above (percentage of remaining life and the average rate of loss of life).

## Parallelism concentrator

It acts as an interface between the Treotech Synchronous Parallelism Supervisor - SPS, and a data acquisition system, adding the functionality of another Treotech equipment, the Serial Communication Module - COMM-04.

**Note:** It is not possible to use the SDV in installations that use the new SPS model, since the new model can also act as a concentrator and no longer depends on other equipment for this function



## Daily cooling activation

This function prevents fans and/or pumps from remaining inactive for long periods in transformers with low loads or during periods of low ambient temperature. This prevents shaft blockage due to dirt buildup or grease drying out. The cooling equipment is activated daily, according to the equipment's internal clock, as selected by the user:

- ✓ Hour and minute of start of fan operation;
- ✓ Total daily fan operating time, from 0 to 999 minutes.

## 2.4. Input, output and communication terminals

### 2.4.1. Inputs

- ✓ Input for measuring the voltage of one of the transformer phases, by regulation PT;
- ✓ Input for measuring line current at the transformer output, using a fixed window-type CT;
- ✓ Three inputs for thermal imaging from a window-type CT;
- ✓ Four window-type CT inputs for monitoring ventilation sets;
- ✓ Three inputs for temperature measurement using 3-wire Pt100  $\Omega$  at 0 °C RTD sensors with self-calibration, ensuring high accuracy and stability over the entire ambient temperature range;
- ✓ Input for measuring potentiometric transmitter, analog signal or BCD digital input, which allows measuring the tap position of the OLTC;
- ✓ Six wet contact inputs for remote commands such as auto/manual, local/remote, tap up/down, and paralleling concentrator enable/disable.

### 2.4.2. Outputs

- ✓ Indication on the display of measured currents, temperatures and voltage;
- ✓ 17 output relays with the following functionalities:
  - Alarm and self-diagnosis indications;
  - Activation of cooling groups;
  - Shutdown based on oil and individual winding temperatures, with adjustable timing from 0 to 20 minutes and a countdown indication on the display;
  - OLTC control for blocking, tap up/down.

### 2.4.3. Communication

- ✓ Fast communication via Ethernet or serial;
- ✓ Redundancy or distribution to multiple systems through its multiple outputs:
  - 1 RS-485 serial communication port;
  - 1 RS-485 or RS-232 serial communication port;
  - 1 dedicated RS-485 port for parallelism concentrator;
  - 1 local RJ45 port for configuration and maintenance;



**Important**

The local RJ45 port should be used **exclusively for configuration and maintenance purposes.**

The SDV offers three models with varying Ethernet communication ports; all support the Modbus RTU/TCP and DNP3 RTU/TCP communication protocols, IEC Goose Publisher, and IEC MMS Server.

- ✓ **FOFO Model:** 2 fiber optic Ethernet ports:



Figure 3 - FOFO Model

- ✓ **FOSR Model:** 1 fiber optic Ethernet port and 1 serial fiber optic port:



Figure 4 - FOSR Model

- ✓ **RJ45 Model:** 2 RJ45 Ethernet ports:

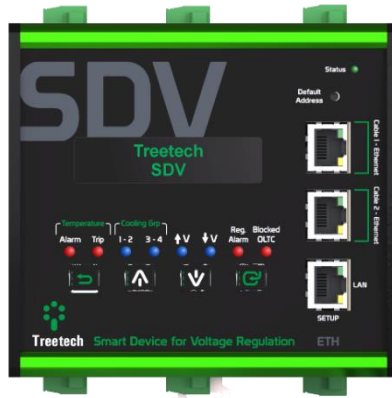

Figure 5 - RJ45 Model



## 3. Design and installation

### 3.1. Installation and removal of terminals

The terminals on the new equipment have been updated and now have screws for better fastening. Therefore, it's important to take some care during installation and removal:

- ✓ Use a 2.5 mm straight screwdriver;
- ✓ Before removing the terminals, check that the screws are completely loose;
- ✓ Forcing removal with screws tight may damage the SDV.

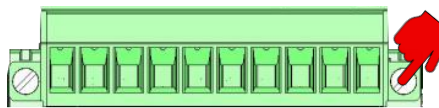

Figure 6 - Terminal with screws

### 3.2. Mechanical installation

The Smart Device for Voltage Regulation - SDV must be installed protected from the elements, either inside panels or in a control room, for example. In either case, there must be an anti-condensation system.

#### 3.2.1. Standard DIN rail installation

This device is compatible with standard DIN rail mounting and can be placed on mounting plates inside panels. It's important to ensure the SDV is securely attached to the rail. If there are no other IEDs nearby, using a rail lock is also recommended. After securing, perform the electrical installation.

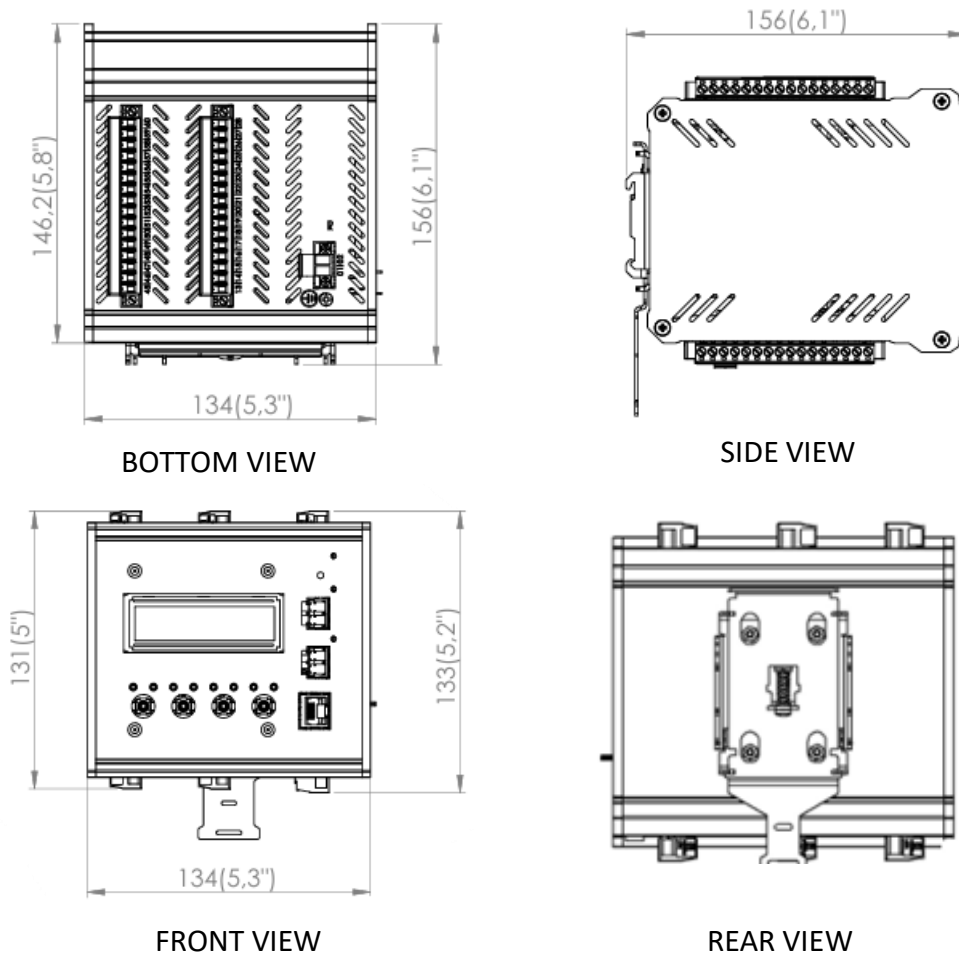

ALL DIMENSIONS IN mm (INCHES)

Figure 7 - SDV dimensions (DIN Rail)

### 3.2.2. Built-in panel installation

The equipment can be installed flush with panels, such as doors or fascias. It's important to consider the thickness of the paint on the panel, as very thick layers can make insertion difficult. It's also essential to ensure a firm fit before performing the electrical installation. Below are the dimensions of the equipment and the cutout required for assembly.

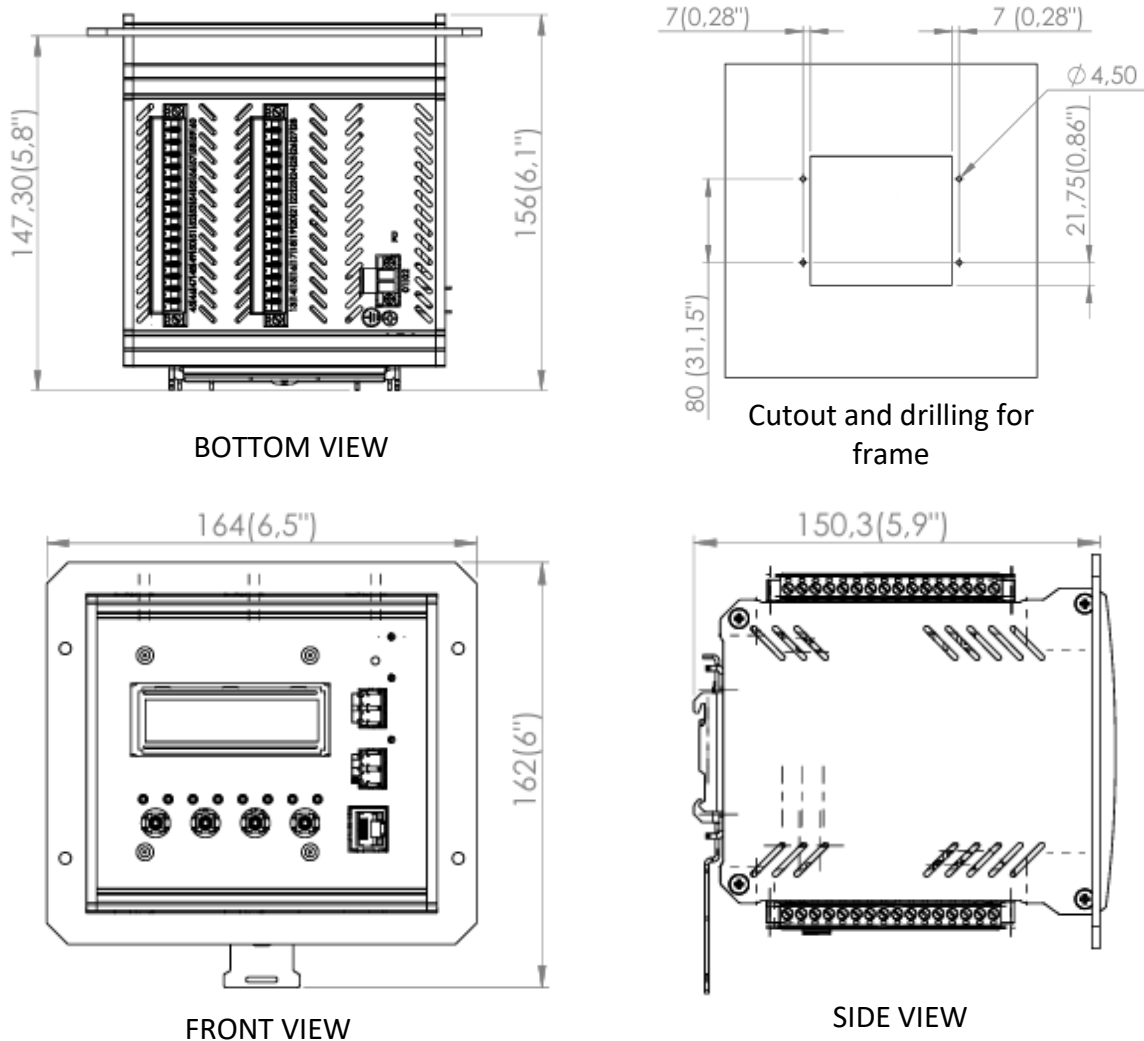

ALL DIMENSIONS IN mm (INCHES)

Figure 8 - SDV dimensions (Panel)

### 3.3. Electrical installation

Some special care must be taken when designing and installing the SDV, as described below:



Study and understand the application in which you intend to use the SDV. Understand the SDV's functional, electrical, and configuration characteristics. This will help you get the most out of the equipment and minimize safety risks.



This equipment operates at dangerous power voltage levels, which could result in death or serious injury to the operator or maintainer.



A circuit breaker must be used immediately before the power input (universal power - 85 to 250 V AC/DC,  $\leq 12$  W, 50/60 Hz), which corresponds to pins 01 and 02 of the SDV.

This circuit breaker must have the number of poles corresponding to the number of phases used in the power supply - and the poles must only interrupt the phases, and never the neutral or ground - and provide thermal and electrical protection to the conductors that supply the equipment.

The circuit breaker must be located near the equipment and easily maneuverable by the operator. Additionally, it must be indelibly labeled to indicate that it is the SDV's electrical disconnect device.



The following circuit breaker specification is recommended when used exclusively for SDV:

- **AC/DC power supply, Phase-to-Neutral:** Single-pole circuit breaker,  $1 \text{ A} \leq I_n \leq 2 \text{ A}$ , curve B or C, standards NBR/IEC 60947-2, NBR/IEC 60898 or IEEE 1015:2006;
- **AC/DC power supply, Phase-to-Phase:** Two-pole circuit breaker,  $1 \text{ A} \leq I_n \leq 2 \text{ A}$ , curve B or C, standards NBR/IEC 60947-2, NBR/IEC 60898 or IEEE 1015:2006.



The connection terminals are installed on the rear of the SDV, in three removable connectors, to facilitate connections. Cables from 0.3 to 2.5 mm<sup>2</sup> can be used, following good installation practices.



The minimum insulation for circuits connected to the SDV is 300 Vrms for auxiliary equipment and transducers, such as Pt100  $\Omega$  at 0°C, and for self-powered equipment up to 50 Vrms. The minimum insulation is 1.7 kVrms for equipment powered up to 300 Vrms, according to IEC 61010-1. These values refer to the intrinsic isolation of the devices connected to the SDV. Cases where this value does not apply to equipment or devices connected to the SDV will be explicitly stated in this manual.

The standard schematic diagram of the SDV connections shows all the connection possibilities that the SDV provides, identifying them, as shown in the following figure.

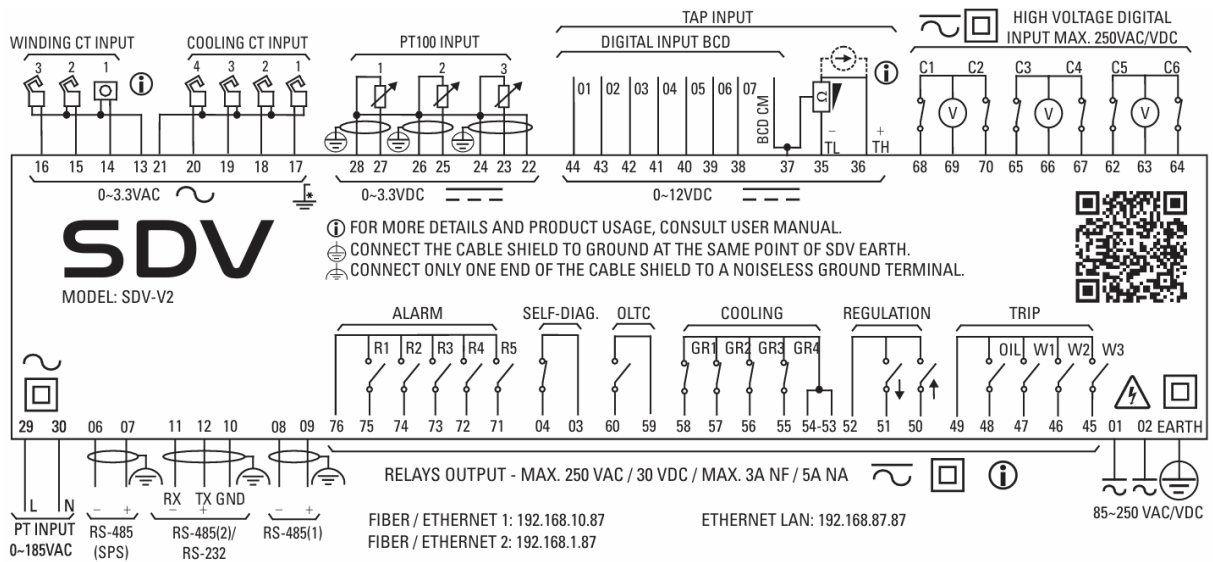

Figure 9 - SDV connection diagram



Special attention must be paid to the correct connection of components to the SDV at all stages of installation. Errors in connecting the equipment can cause risks or even irreversible damage to the operator. Damage due to improper use is not covered by the warranty.

The following sections will present the connections and functions of the equipment's inputs, outputs and communications in more detail.

### 3.3.1. Input terminals

The Smart Device for Voltage Regulation – SDV has the following inputs:

#### 3.3.1.1 Power and grounding

Table 2 - SDV power and ground

Power and grounding	Terminals
Universal power inputs 85 to 250 V DC/V AC, 50/60 Hz, $\leq 12$ W.	 — Ground 01 — DC/AC 02 — DC/AC

#### 3.3.1.2 Current inputs

Table 3 - Current inputs

Inputs	Terminals
<b>Input for cooling CT</b> Clip-on window CT current measurement input. Measuring range 0 to 10 A.	17 – $I_1$ 18 – $I_2$ 19 – $I_3$ 20 – $I_4$ 21 – Common
<b>Input for winding CT</b> Input for current measurement for thermal images, where it is possible to remotely select the $I_{win}$ to be used for regulation current.  If only one transformer winding is to be monitored, the CT for calculating the thermal image must be connected to terminals 13 and 14. This CT can also be used for regulation, or alternatively, another input can be used to connect the regulation CT.	13 – Common 14 – $I_{win1}$ 15 – $I_{win2}$ 16 – $I_{win3}$

It is important that the primary nominal current of the winding CT (the current coming from the transformer CT) be less than 10 A. If this is not possible, it is necessary to use a shunt resistor or some other method to reduce the current to an appropriate value.

Due care must be taken when connecting the transformer CT input to ensure it does not remain open during operation. If interventions are made on this circuit with the transformer energized, ensure that the equipment's instrument CT is short-circuited and grounded at the panel terminals.

If the SDV has regulation functionality, the winding CT input for regulation must be specified in the configuration. This CT is a window type with a non-sectionable core, unlike the clip-on CT typically used for thermal imaging. The measurement range on the CT primary is 0 to 10 Aca rms, with an error of 1% of the measurement with loads up to 300  $\Omega$ . It is worth noting that, if the winding in which the regulation is made is also being monitored for the calculation of the thermal image, the current measured by the regulation CT is already sufficient for the calculation, and it is not necessary to place a clip-on CT in this winding.

There are several possible CT connection combinations; each combination produces an angular phase shift between the voltage and current signals. When programming the SDV, the phase shift angle between the signals is adjusted from 0° to 330° in 30° steps, which will be used in compensation for the correct power factor calculation.

The following are examples of some possible CT connection combinations. Other combinations are possible, and the phase shift angle can be easily determined by drawing the phasor diagram as shown in the examples.

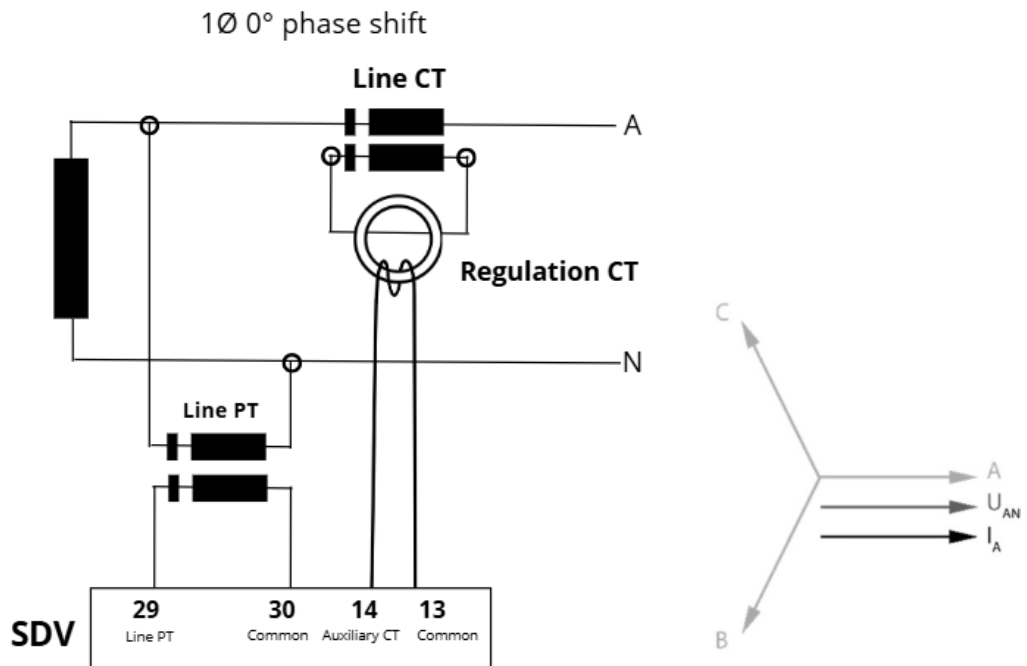

Figure 10 - Connection for single-phase transformer, 0° phase shift

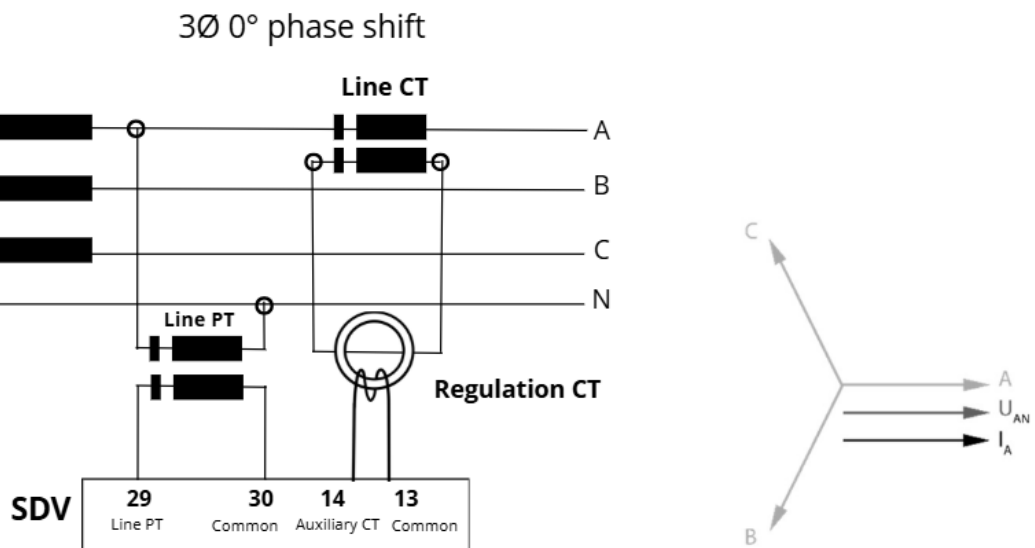

Figure 11 - Connection for phase-neutral PT, 0° phase shift

### 3Ø 0° phase shift

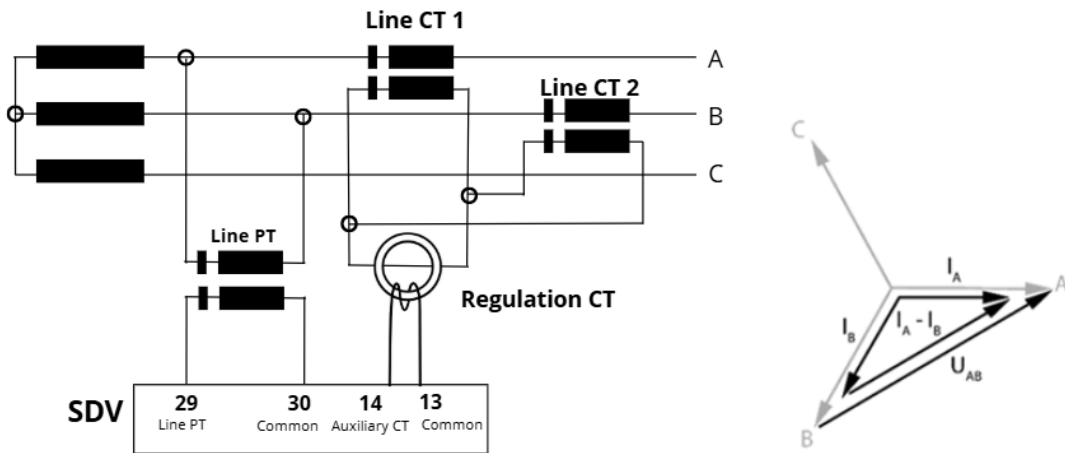

Figure 12 - Connection for phase-to-phase PT, 0° phase shift

### 3Ø 150° phase shift

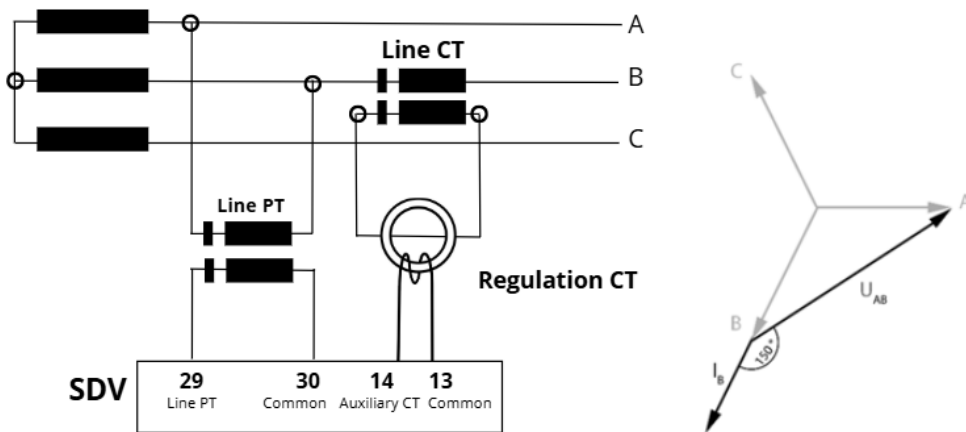

Figure 13 - Connection for phase-to-phase PT, 150° phase shift

### 3Ø 210° phase shift

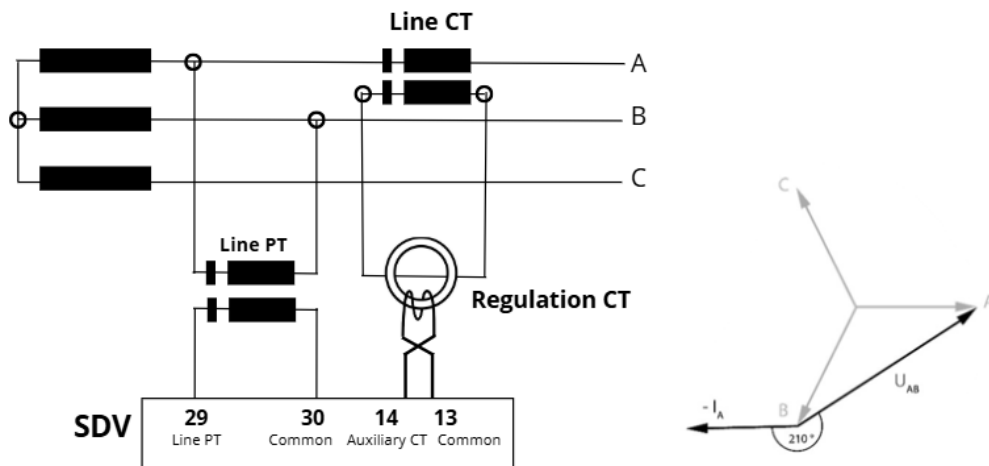

Figure 14 - Connection for phase-to-phase PT, 210° phase shift

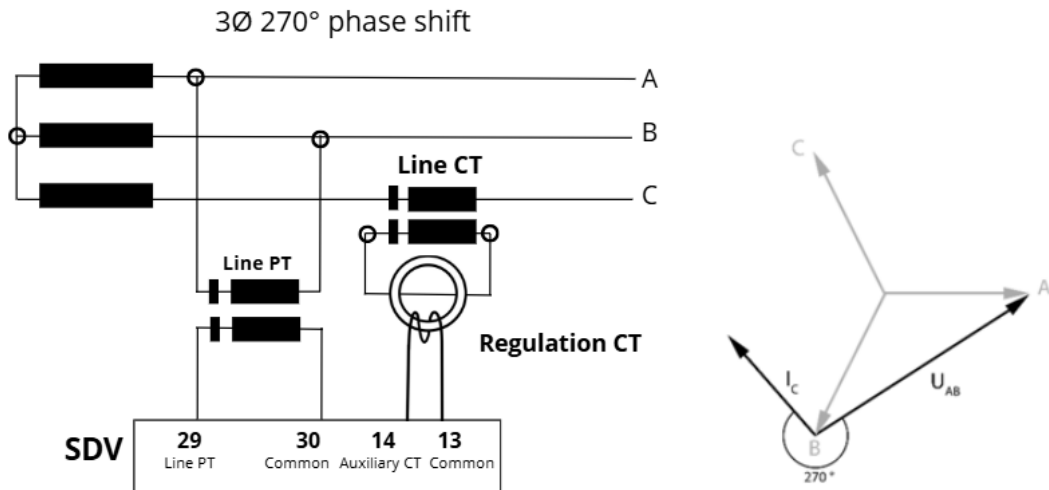

Figure 15 - Connection for phase-to-phase PT, 270° phase shift

### 3.3.1.3 Temperature sensors

Table 4 - Input for Pt100

Input for Pt100	Terminals
To monitor the transformer oil temperature and other temperatures required by the application, the SDV has three inputs for Pt100 $\Omega$ sensors at 0 °C.	27 – VM RTD 1 28 – White RTD 1
	25 – VM RTD 2 26 – White RTD 2
	23 – VM RTD 3 24 – White RTD 3
	22 – Common

The SDV has three inputs for Pt100  $\Omega$  RTD temperature sensors at 0°C. One input is intended for measuring the top of the transformer oil temperature, while the others can be used to measure ambient temperature, transformer oil temperature redundancy, tap changer oil temperature, or any other desired temperature.

The temperature sensor must be connected to the SDV with shielded cables, without interruption to the shield, which must be grounded only at the end connected to the SDV. If intermediate terminals are necessary, the cable shield must pass through them, avoiding interruptions, and the unshielded cable section must be as short as possible.



The maximum resistance for each of the paths used in the SDV interconnection cable with the PT100 sensors is 3  $\Omega$ . In other words, 6  $\Omega$  for the round trip from the PT100 sensor to the SDV.



Considering the maximum resistance allowed in the connection between the PT100 and the SDV, for a copper cable with a gauge of 1.5 mm<sup>2</sup>, the PT100 can be installed at a maximum distance of 265 m from the SDV. Other values will be possible with the correct cable sizing. If you need support for cable sizing, contact Treotech CS.

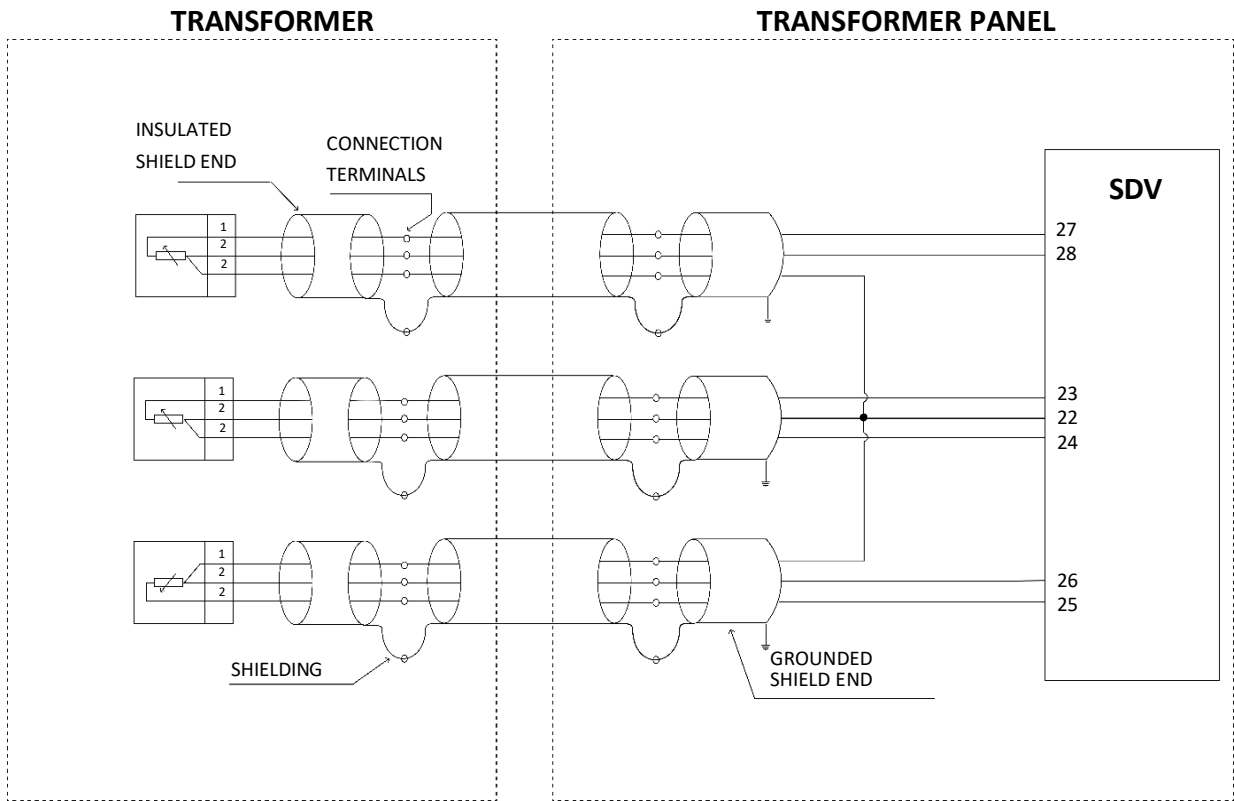

Figure 16 - Connection of the interconnection shield between RTD sensors and the SDV

### 3.3.1.4 Voltage input

Table 5 - Voltage input

PT input	Terminals
The input for measuring one of the transformer voltages is important for performing functions related to voltage regulation.	29 – AC 30 – AC

### 3.3.1.5 Tap measurement input

#### 3.3.1.5.1 Potentiometric transmitter

Table 6 - Tap measurement by potentiometric transmitter

Tap measurement by potentiometric transmitter	Terminals
To measure the tap position, you need to connect a potentiometric transmitter to the SDV. This table indicates the inputs used by the transmitter. Installation will be explained in more detail later.	37 – cursor 35 – Minimum TAP 36 – Maximum TAP

The tap position measurement is carried out through a specific input for connecting a potentiometric position transmitter of the on-load tap changer.

#### Connection cables for tap measurement

The tap changer's potentiometric position transmitter is connected to the SDV using three wires: the cursor, the start, and the end of the potentiometric transmitter. The three wires must be the same length and gauge. Shielded cable must be used for this connection throughout the entire length from the tap changer cabinet to the SDV, with the shield grounded at a single point.

If a single shielded cable is not used, shield continuity must be ensured by connecting the ends of the cable shields, as shown in the following figure. The unshielded section due to the splice should be as short as possible.

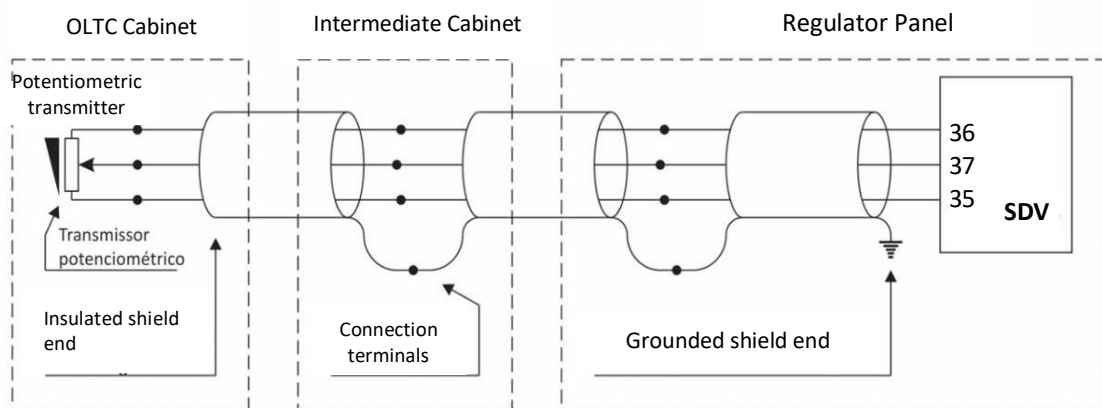

Figure 17 - Connecting the shielding of the TAP measuring cables

Automatic resistance compensation is provided for the connecting cables between the potentiometric transmitter and the SDV, requiring that all three wires be the same length and gauge, with a maximum resistance of  $8 \Omega$  per wire. Based on this resistance and the wire gauge, the maximum allowable length can be determined. For untinned cables, stranding class 4, the maximum lengths are shown in the following table.

Table 7 - Maximum length for tap measuring cable gauges



Cable gauge	Typical resistance	Maximum length
0.5 mm <sup>2</sup>	39.0 Ω/km	200 m
0.75 mm <sup>2</sup>	26.0 Ω/km	300 m
1 mm <sup>2</sup>	19.5 Ω/km	400 m
1.5 mm <sup>2</sup>	13.3 Ω/km	600 m
2.5 mm <sup>2</sup>	7.98 Ω/km	1000 m
4 mm <sup>2</sup>	4.95 Ω/km	1600 m

### Requirements for tap position transmitter

It is possible to configure the initial and final offset, the resistance step in the tap change, the tap change time, maximum and minimum tap limits and the parameters related to the intermediate taps.

In the case of tap changers with “intermediate” positions, that is, transition positions that have the same voltage as other adjacent positions, it is possible to parameterize the number of transitions with intermediate taps found in the tap changer, the number of intermediate positions in each transition, and whether these positions have resistance or are short-circuited.

The following shows the configuration of each parameter, based on the example potentiometric transmitter in [Figure 18](#), with its data in the following table. All intermediate positions (in the example, 6A, 6, 6B and 6C) will be indicated as tap "6", since they have the same voltage.

Table 8 - Resistance of the cursor indicating the TAP position

TAP position	Voltage (V)	Current (A)	Resistance measured between cursor and starting position
1	12420	3220.6	0
2	12696	3150.6	10
3	12972	3083.6	20
4	13248	3019.3	30
5	13524	2957.7	40
6A	13800	2898.6	50
6			
6B			
6C			
7	14076	2841.7	60
8	14352	2787.1	70
9	13800	2734.5	80
10	14904	2683.8	90

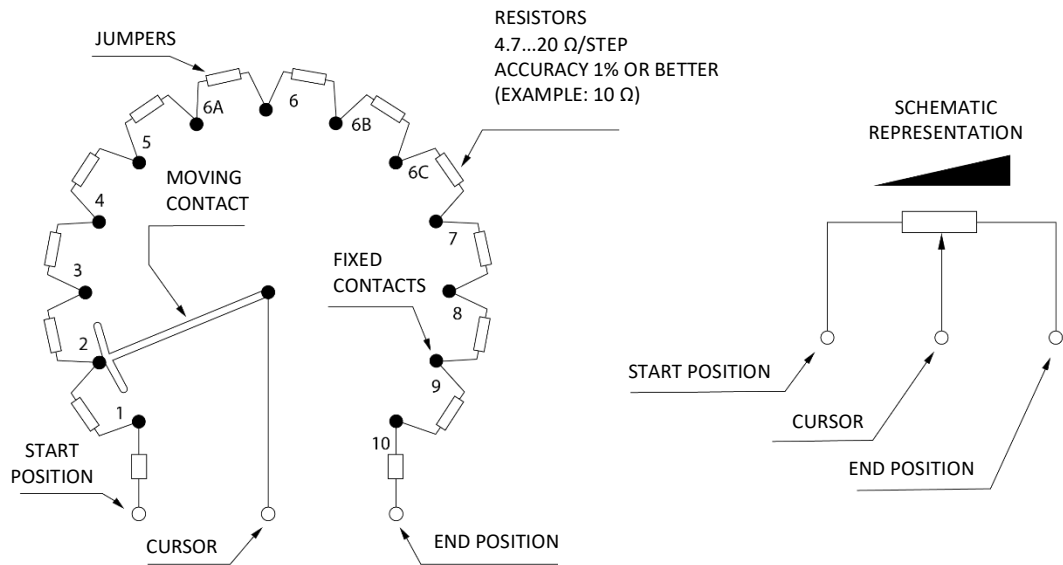

Figure 18 - Configuration of the potentiometric transmitter resistors in the intermediate positions of the OLTC

The SDV allows the step resistance of the potentiometric transmitter to be in the range of 4.7 to 20 Ω, and the total resistance of the transmitter to be from 4.7 to 1400 Ω. The value of each individual resistor is shown in [Figure 19](#), at the RS value. The moving contact (cursor) of the potentiometric transmitter can be either of the "close before it opens" or "open before it closes" type, indifferently. The resistances of the potentiometric transmitter must be of precision, that is, with error tolerances of no more than 1%.

In this case, the SDV parameterization about the OLTC must be done considering the resistance value per step (RS). The parameter "Initial Offset" must be parameterized with the value of the initial resistance (IR). The final resistance (FR) can be entered in the parameter "Final Offset". Remember that if there are no initial and final resistances, the corresponding offset values must be set to 0

It is necessary to add the number of monitored tap positions (in this case it is 10), in addition to the minimum tap (1) and maximum tap (10) values that can be reached by the tap changer. The tap change time must also be entered.

For intermediate transition parameterization, the SDV requires the adjustment of each existing intermediate transition. There can be a maximum of three distinct intermediate positions, with up to five jumps between them. In the example, we have two intermediate transitions: from tap 5 to tap 6 and from tap 6 to tap 7.

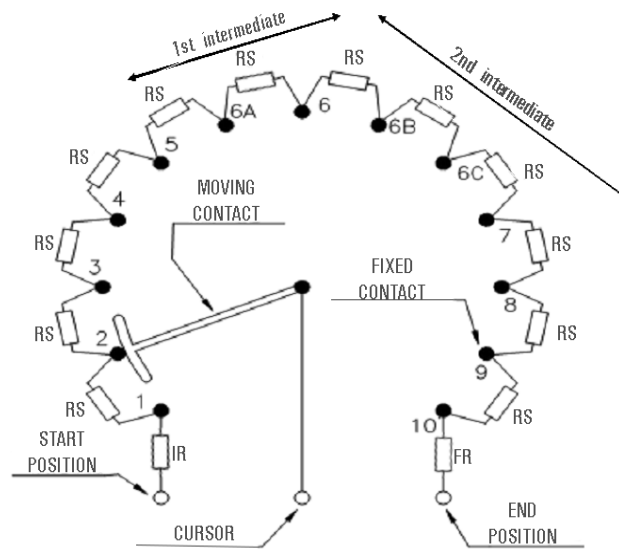

Figure 19 - Illustration of intermediate taps

To configure the first intermediate transition, the SDV needs to indicate the tap change for that transition, which in this case is from tap 5 to tap 6. Additionally, it is necessary to enter the number of intermediate transitions until the transition is complete. In this case, we have two transitions (5 - 6A and 6A - 6). Finally, it is necessary to indicate whether this transition has resistance or not. Some manufacturers and some installations have short-circuited intermediate taps. In these cases, the parameterization should indicate that the intermediate taps have no resistance. In the example in this manual, there is resistance, which should be indicated in the SDV.

In the second intermediate transition, the parameterization is done in a similar way. The tap passage indication should be from tap 6 to tap 7, the number of passages is 3 (6 - 6B, 6B - 6C, 6C - 7), and the resistance indication should be "YES" in the parameter for the presence of resistance in the intermediate taps.

The ongoing tap position of the associated on-load tap changer can be reported in the following formats: simple numeric (1...17), bilateral numeric (-8...0...+8) or alphanumeric (8L...N...8R).

If the number of taps is 10, for example, and the representation is not simple numeric, it will be necessary to additionally inform the center tap, which will be the tap considered as 0 in the bilateral classification, or N in the alphanumeric scale. From this value, the SDV corrects the tap indication according to the adjusted center tap value.

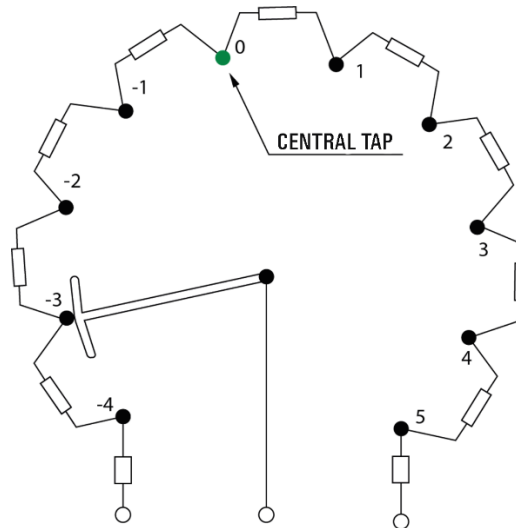

Figure 20 - Central tap indication

### 3.3.1.5.2 BCD digital input

Table 9 - Tap measurement by BCD digital input

Tap measurement by BCD digital input	Terminals
Tap position measurement by BCD digital input consists of encoding decimal values into binary.	38 – 07 39 – 06 40 – 05 41 – 04 42 – 03 43 – 02 44 – 01 37 – Common BCD

The SDV has seven digital inputs for BCD, with each tap represented in binary-coded decimal form, as shown in the following image:

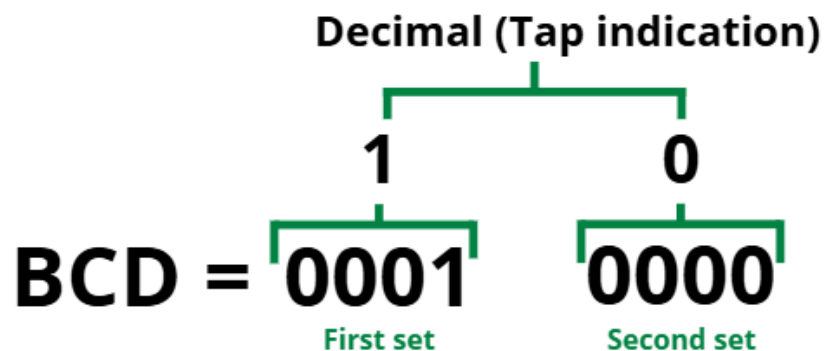

Figure 21 - BCD digital input

It is possible to observe that, to represent the number 10, in the decimal base in binary, two sets of 4 bits will be necessary, as this number has two digits.

### 3.3.1.5.3 Analog signal (mA)

Table 10 - Tap measurement by analog signal (mA)

Tap measurement by analog signal (mA)	Terminals
Tap position measurement by analog signal (mA) consists of connecting an analog signal (mA) to the SDV that indicates the tap changer position based on the variation in current.	35 – mA (-) 36 – mA (+)

Installation becomes simpler; just connect it to pins 35 and 36, as shown in the figure below:

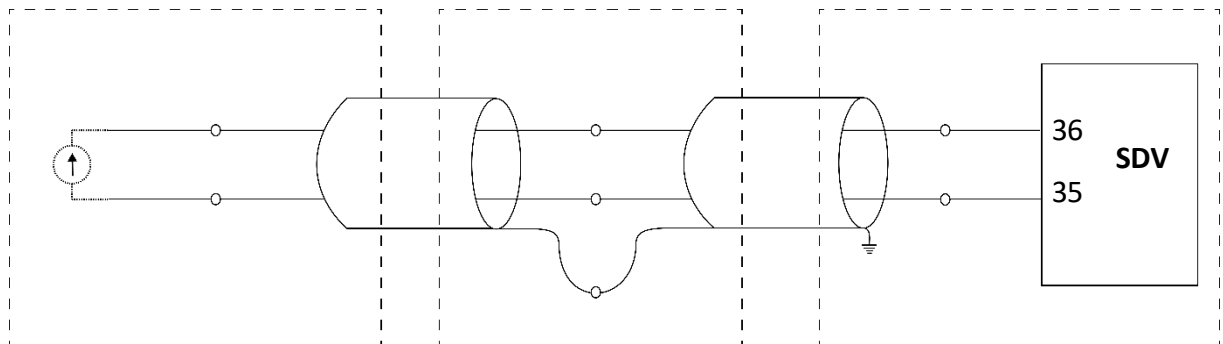

Figure 22 - Tap position measurement by analog signal

The cable used for this connection must be shielded and grounded at only one end. Unshielded cable sections should be as short as possible, and if a splice is necessary, run the shield through the terminal strip as well so it is not interrupted.

### 3.3.1.6 Wet contact inputs

Table 11 - Wet contact inputs

Wet contact inputs	Terminals
Wet contacts are used to send commands and change equipment parameters.	62 – C5 63 – Common 64 – C6 65 – C3 66 – Common 67 – C4 68 – C1 69 – Common 70 – C2

The wet contacts used to send commands and change equipment parameters require an external power source as shown in [Table 12](#). Through these contacts, the SDV can receive instructions from a remote source, enabling the following operations:

- Command to switch between automatic/manual mode;
- Command to switch between local/remote mode;
- Tap up/down command (accepted only in remote and manual modes);

- Command to enable/disable the parallelism concentrator;
- OLTC block:
  - ✓ Activates the OLTC blocking alarm by triggering the relays;
  - ✓ Prevents automatic tap change commands, but allows manual commands.

 The reading mode follows the configuration of the parameters associated with the wet contacts, which behave according to the logic of the received signal:

- ✓ **State:** parameters follow the state of the contact (0 when open, 1 when closed).
- ✓ **Pulse:** the regulation parameters are switched on the rising edge of the signal (contact closure);

Next is an example of a connection for wet contact actuation.



**Important**

In order for the input status to be correctly interpreted as **activated** or **not activated**, the values indicated in [Table 12](#) must be observed. In the intermediate range between these limits, the input behavior may be unstable, alternating between the two states. For this reason, the voltage limits specified for contact activation must be respected.

Table 12 - Input state

Estado de entrada	Tensão de alimentação
0	0~20 VAC/VDC
1	48~250 VAC/VDC

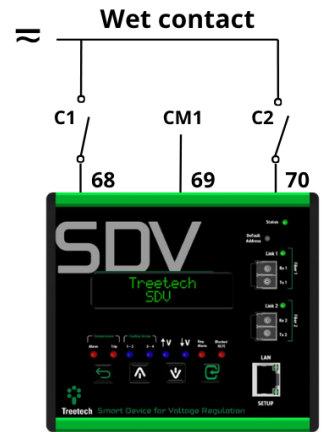

Figure 23 - Wet contact connection

### 3.3.2. Output terminals

The table below shows the SDV output terminals, with the relay nomenclature following the connection diagram shown in [Figure 9](#).

Table 13 - SDV output terminals

Output	Terminals	
<p><b>Configurable function relays</b></p> <p>The SDV has seventeen output relays. Relays 1 through 5 are user-configurable, and the others have a fixed function.</p> <p>R1 - Configurable; R2 - Configurable; R3 - Configurable; R4 - Configurable; R5 - Configurable;</p> <p>Configurable relays can be associated with alarms according to user parameters. Additionally, these relays can operate in NC mode, as long as they are configured this way via the web page.</p>	R1	75 – NO 76 – Common
	R2	74 – NO 76 – Common
	R3	73 – NO 76 – Common
	R4	72 – NO 76 – Common
	R5	71 – NO 76 – Common
<p><b>Single contact relays</b></p> <p>OIL - Oil temperature shutdown relay; W1 - Winding 1 temperature shutdown relay; W2 - Winding 2 temperature shutdown relay; W3 - Winding 3 temperature shutdown relay; GR1 - Forced ventilation group 1 activation relay; GR2 - Forced ventilation group 2 activation relay; GR3 - Forced ventilation group 3 activation relay; GR4 - Forced ventilation group 4 activation relay;</p>	OIL	48 – NC 49 – Common
	W1	47 – NC 80 – Common
	W2	46 – NC 49 – Common
	W3	45 – NC 49 – Common
	GR1	58 – NC 53/54 – Common
	GR2	57 – NC 53/54 – Common
	GR3	56 – NC 53/54 – Common
	GR4	55 – NC 53/54 – Common
<p><b>OLTC relay</b></p> <p>Potential-free NO relay for OLTC blocking. This relay can also operate in NC mode, provided it is configured this way via the web page.</p>	OLTC	60 – NO 59 – Common
<p><b>Regulation relays</b></p> <p>Potential-free NO relays for raising and lowering voltage.</p> <p>↑ - Control relay to increase voltage; ↓ - Control relay to decrease voltage;</p>	↑	50 – NO 52 – Common
	↓	51 – NO 52 – Common



<p><b>Self-diagnosis relay</b></p> <p>Potential-free NC relay for self-diagnosis indication.</p>	SELF-DIAG	03 – Common 04 – NC
--	-----------	------------------------

### 3.3.3. Communication ports

Table 14 - SDV Communication Terminals

Communication	Purpose	Terminals
<p><b>Ethernet port</b></p> <p>Communication port via RJ45 or SC multimode optical fiber for communication between SDV and control/supervisory system or communication with IEDs. Output protocols Modbus<sup>®</sup> TCP (slave), Modbus<sup>®</sup> RTU/TCP (slave), DNP3 TCP (outstation) and IEC 61850 (server and publisher).</p>	User	-
<p><b>Serial fiber optic port</b></p> <p>SC multimode fiber optic communication port for communication between SDV and control/supervisory system or communication with IEDs. Modbus<sup>®</sup> RTU (slave) and DNP3 RTU (outstation) output protocols.</p>	User	-
<p><b>RS-485 Ports — Serial communication network with monitoring or supervisory system</b></p> <p>Connection to monitoring or supervisory system, using Modbus<sup>®</sup> or DNP3 protocol.</p> <p>Use shielded twisted pair cable.</p>	User	<p><b>RS-485 (1)</b> 08 – (-) 09 – (+)</p> <p><b>RS-485 (2)</b> 11 – (-) 12 – (+)</p>
	Parallelism	<p><b>RS-485 (SPS)</b> 06 – (-) 07 – (+)</p>
<p><b>RS-232 – Communication port</b></p> <p>The SDV has an RS-232 communication port for connection to any control, supervision or monitoring system.</p> <p>Communication is done with the Modbus<sup>®</sup> or DNP3 protocol, using a shielded and twisted three-core cable.</p>	User	<p><b>RS-232</b> 10 – GND 11 – RX 12 – TX</p>

### 3.3.3.1 Precautions when installing the RS-485 network

#### 3.3.3.1.1 Communication with the data acquisition system

Up to 31 devices can be connected to a single communication network. The communication protocols available for this connection are Modbus® and DNP3.

The SDV and the data acquisition system must be connected using a shielded twisted-pair cable, maintaining an uninterrupted shield throughout. If intermediate terminals are required for serial communication interconnection, also pass the cable shield through the terminal to avoid interruption.

In conjunction with the termination resistors, pull-up and pull-down resistors must be used at only one point in the network, as shown in the [Figure 23](#).

The 5 V DC voltage for powering the pull-up and pull-down resistors can be internal to the data acquisition system. Note that some communication equipment may already have these resistors installed internally, eliminating the need for external resistors. A maximum distance of 1200 m between the ends of the communication network must be observed.

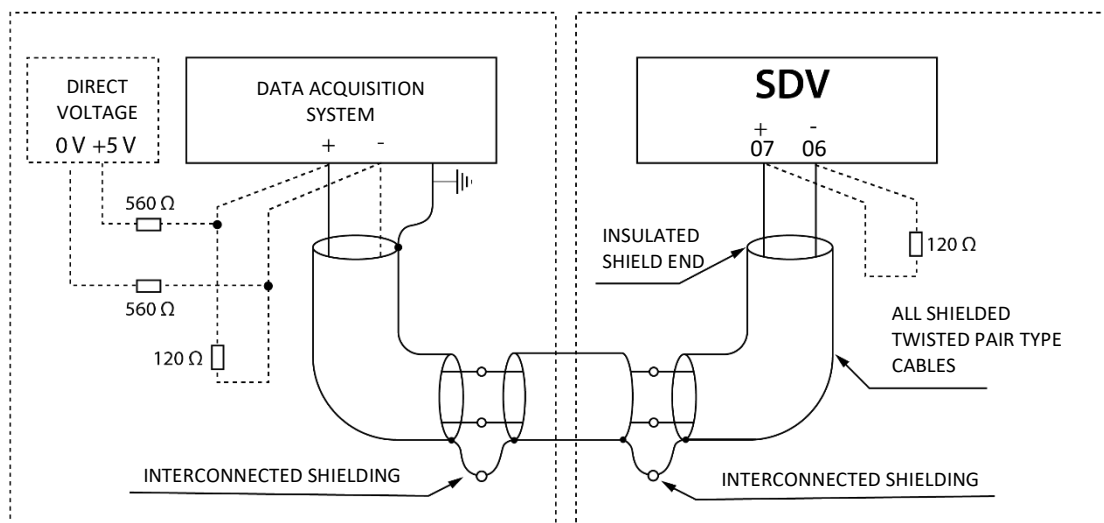

Figure 24 - RS-485 serial communication shield connection and grounding

#### 3.3.3.1.2 Parallelism communication

For the SDV to act as a parallelism concentrator, the SDV and all SPSs participating in the parallelism must be interconnected by connecting their RS-485 ports in parallel, as shown in [Figure 25](#).

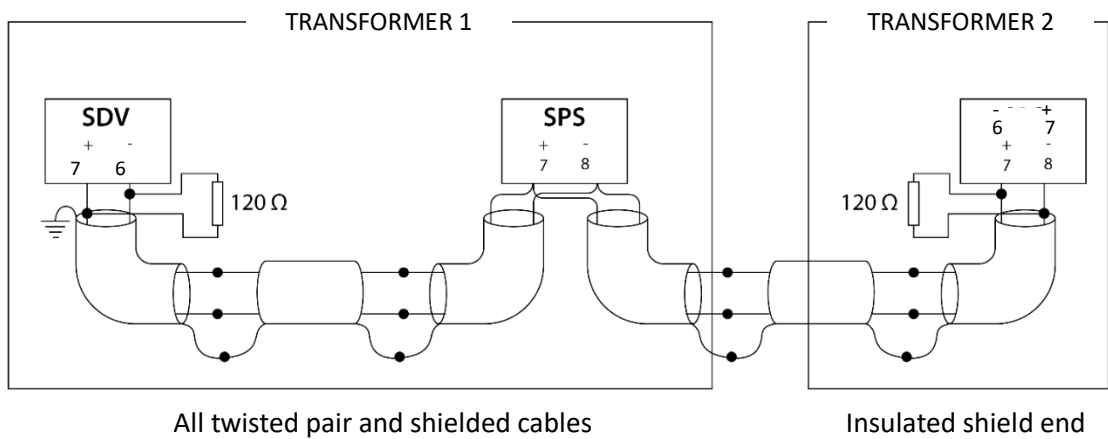

Figure 25 - SDV interconnection as a parallelism conc





**Important**

As shown in the topics above on interconnecting RS-485 with the supervisory system and with parallelism, it is important to remember that, if there is a need for intermediate terminals for interconnecting serial communication, pass the cable shield through the terminal, avoiding its interruption.

The unshielded cable section due to the splice should be as short as possible. It is recommended that the cable shield be grounded at only one end and that a 120-ohm termination resistor be installed at each end of the serial communication.

## 4. Operation

The Smart Device for Voltage Regulation provides a variety of information to help monitor transformer operating conditions. This information can be accessed using the  and  during normal operation. The features are accessible exclusively through its web interface, which provides real-time information on measurements, operational status, alarms, and self-diagnosis procedures.

All operations on the Smart Device for Voltage Regulation - SDV can be performed using the keypad located on its front panel. Voltages, currents, and other measurements are shown on the display, while alarm conditions are indicated by LEDs.

### 4.1. Signaling LEDs



Figure 26 - Arrangement and function of LEDs

Indicates the **Operational Status**, as follows:

**Blue:** Power supply initialization and blinking during system boot;

**Green (continuous):** Indicates normal operation;

**Yellow:** Indicates active self-diagnosis.

**Red:** Indicates communication failure between the boards.

**Flashing:** Indicates that the default address button has been pressed, flashing in yellow, green, and red.

**Default Address Button:** pressed for 5 seconds, applies a temporary reset to the IPs of the fiber and RJ45 ports, returning them to the factory default until the next restart of the equipment.

Indicates **Communication Status**:

**Off:** No connection;

**On:** Connected;

**Flashing:** Indicates connection and activity on the network, that is, it is communicating.

The LEDs on the front of the SDV are divided into the categories “Temperature”, “Cooling Grp” and LEDs related to regulation, which have the following functions:

**Alarm:** It stays on when an oil or winding temperature alarm occurs. It will flash when the screen shown on the display refers to the measurement causing the alarm.

**Trip:** due to transformer shutdown because the oil or winding temperature. It will flash when the screen shown on the display refers to the measurement causing the alarm.

**Cooling group 1-2 and 3-4:** Stays lit while cooling group 1-2 or 3-4 is active.

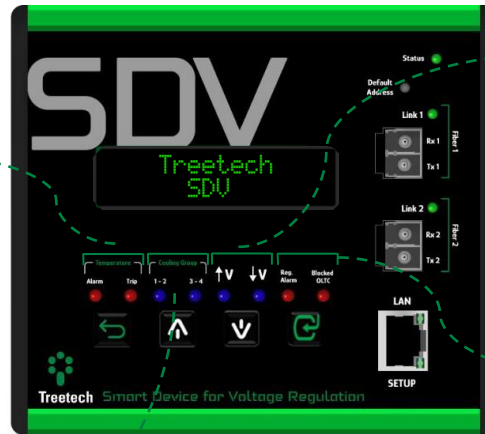

Figure 27 - SDV front LEDs

**V↑ and V↓:** Flashes while action is required to raise or lower voltage.







**Reg. Alarm:** Lights up when one of the following alarms occurs: I>, U<, U>, or I<. The display will indicate the specific alarm.

**Blocked OLTC:** Blocked tap changer alarm.

## 4.2. Key function



The keys have the following functions:

Table 15 - SDV key functions

Key	Function
	<b>Programming key:</b> In the menu shown on the display, exits the current menu and returns to the previous level menu.
	<b>Up key:</b> Navigation between measurement screens and programming menus.
	<b>Down key:</b> Navigation between measurement screens and programming menus.
	<b>Enter key:</b> Press to select the menu option shown on the display or save the command change made to the equipment. If the key  is pressed before  in a command change, it will not be saved.

## 4.3. Contrast adjustment

On the initial measurement screen, hold the key  down for 3 seconds to access the contrast adjustment screen.

Use the keys  and  to increase and decrease the brightness, respectively.





Press the key  to save the new setting, and the key  to return to the indication screens.



Figure 28 - SDV contrast adjustment

## 4.4. Query screens

The Smart Device for Voltage Regulation provides a variety of information to guide you through the transformer's operating conditions. This information is accessed via the Keys  and  during normal operating mode.

## 4.5. General screen





The following information will be displayed on the device's displays. Pressing the key  will show the reverse order to that indicated below:

Table 16 - SDV query screens

SDV query screens	
<p><b>Alarm Status</b> Indicates the general status of the equipment in relation to alarm triggering.</p> <p><b>Normal:</b> no active alarm. <b>Triggered:</b> active alarm.</p>	
<p><b>Top Oil Temp. – Oil temperature</b> Indicates the transformer oil temperature.</p>	
<p><b>Wind. 1 Temp. – Winding 1 temperature</b> Indicates the temperature of the first winding of the transformer.</p>	



<p><b>Wind. 2 Temp. – Winding 2 temperature</b> Indicates the temperature of the second winding of the transformer.</p>	
<p><b>Wind. 3 Temp. – Winding 3 temperature</b> Indicates the temperature of the third winding of the transformer.</p>	
<p><b>Loading – Loading</b> Shows, in relation to the nominal load, the percentage loading of each transformer winding.</p>	
<p><b>Active reg. – Active regulation set</b> Indicates which regulation set is currently active.</p>	
<p><b>Operation mode</b> Indicates the SDV operating mode (automatic or manual) and the command mode (local or remote).</p>	
<p><b>Voltage and load deviation</b> Indicates the charging voltage and its deviation from the nominal voltage.</p>	
<p><b>Power</b> Indicates active, reactive and apparent power and percentage of transformer load.</p>	
<p><b>Current TAP Pos. – TAP position</b> Indicates the position in which the tap is currently located.</p>	
<p><b>Temperature – Temperature submenu</b> Press the key  to continue navigating between the advanced temperature query screens. This screen will only be displayed if the “Enable temperature functionality” parameter, located in item <a href="#">5.4.1.1</a>, is set to “YES.”</p>	
<p><b>Regulation – Regulation submenu</b> Press the key  to continue navigating between the advanced regulation query screens. This screen will only be displayed if the “Enable regulation functionality” parameter, located in item <a href="#">5.4.1.1</a>, is set to “YES.”</p>	
<p><b>General – General submenu</b> Press the key  to continue navigating between the general advanced query screens.</p>	



### 4.5.1. Advanced temperature query

This submenu will only be displayed if the parameter “Enable temperature functionality,” located in item [5.4.1.1](#), is set to “YES.”

Table 17 - Temperature submenu information

Temperature submenu information	
<p><b>Temperature – Temperature submenu</b></p> <p>This submenu presents aspects related to temperature and load measurement.</p> <p>Use the arrows to continue navigating through other information or press  on this screen to access the submenu and consult the secondary screens. Once inside, navigate using the arrows  and . To return to the previous level, press .</p> <p>To reset the maximum values indicated in the following menus, press the key  on the measurement you want to reset for 3 seconds.</p>	
<p><b>Max. Oil Temp. – Maximum oil temperature</b></p> <p>Indicates the maximum temperature reached by the transformer oil since the last time this marker was reset.</p>	
<p><b>Max WindTemp. 1 – Maximum temperature of winding 1</b></p> <p>Indicates the maximum temperature reached by winding 1 of the transformer since the last time this marker was reset.</p>	
<p><b>Max WindTemp. 2 – Maximum temperature of winding 2</b></p> <p>Indicates the maximum temperature reached by winding 2 of the transformer since the last time this marker was reset.</p>	
<p><b>Max WindTemp. 3 – Maximum temperature of winding 3</b></p> <p>Indicates the maximum temperature reached by winding 3 of the transformer since the last time this marker was reset.</p>	
<p><b>Final grad.1 – Final gradient 1</b></p> <p>Indicates what the final temperature gradient between the oil and winding 1 will be if the current loading is maintained.</p>	
<p><b>Final grad.2 – Final gradient 2</b></p> <p>Indicates what the final temperature gradient between the oil and winding 2 will be if the current loading is maintained.</p>	
<p><b>Final grad.3 – Final gradient 3</b></p> <p>Indicates what the final temperature gradient between the oil and winding 3 will be if the current loading is maintained.</p>	
<p><b>Wind. Curr. 1 – Winding 1 current</b></p> <p>The current flowing through winding 1 of the transformer.</p>	
<p><b>Wind. Curr. 2 – Winding 2 current</b></p> <p>The current flowing through winding 2 of the transformer.</p>	



<p><b>Wind. Curr. 3 – Winding 3 current</b> The current flowing through winding 3 of the transformer.</p>	
<p><b>Sec. Curr. 1 – Current in the secondary of the CT of winding 1</b> Indicates the current in the secondary of the CT of winding 1.</p>	
<p><b>Sec. Curr. 2 – Current in the secondary of the CT of winding 2</b> Indicates the current in the secondary of the CT of winding 2.</p>	
<p><b>Sec. Curr. 3 – Current in the secondary of the CT of winding 3</b> Indicates the current in the secondary of the CT of winding 3.</p>	
<p><b>Sensor Pt 1 – Pt 1 sensor temperature</b> Shows the temperature measured by Pt100 sensor 1, which can be redundant (oil), ambient, bypass switch, oil thermowell, etc.</p>	
<p><b>Sensor Pt 2 – Pt 2 sensor temperature</b> Shows the temperature measured by Pt100 sensor 2, which can be redundant (oil), ambient, bypass switch, oil thermowell, etc.</p>	
<p><b>Sensor Pt 3 – Pt 3 sensor temperature</b> Shows the temperature measured by Pt100 sensor 3, which can be redundant (oil), ambient, bypass switch, oil thermowell, etc.</p>	
<p><b>Pt Max Temp. 1 – Maximum temperature 1</b> Shows the maximum temperature measured by Pt100 sensor 1 since the last time this marker was reset.</p>	
<p><b>Pt Max Temp. 2 – Maximum temperature 2</b> Shows the maximum temperature measured by Pt100 sensor 2 since the last time this marker was reset.</p>	
<p><b>Pt Max Temp. 3 – Maximum temperature 3</b> Shows the maximum temperature measured by Pt100 sensor 3 since the last time this marker was reset.</p>	
<p><b>Active Groups – Active groups</b> Indicates which cooling groups are currently active.</p>	
<p><b>LTC. Temp. Diff. – OLTC temperature differential submenu</b> Press the key  to enter the advanced query submenu related to the on-load tap changer temperature differential.</p>	
<p><b>Cooling Group – Cooling group submenu</b> Press the key  to enter the submenu related to the cooling group.</p>	
<p><b>Insulation Aging – Insulation aging submenu</b> Press the key  to enter the submenu related to insulation aging</p>	

### 4.5.1.1 OLTC temperature differential (OLTD)

Table 18 - OLTD Submenu

<b>OLTD submenu information</b>	
<p><b>LTC. Temp. Diff. – OLTC temperature differential submenu</b>            This submenu presents the tap changer temperature measurement, in relation to the transformer oil temperature.</p> <p>Use the arrows to continue navigating through other information or press  on this screen to access the submenu and consult the secondary screens. Once inside, navigate using the arrows  and . To return to the previous level, press .</p>	
<p><b>OLTD Status – OLTC temperature differential status</b>            Indicates the ongoing status of the tap changer temperature differential monitoring.</p>	
<p><b>Inst. Dif. Temp. – Instantaneous temperature differential</b>            Instantaneous temperature differential between transformer oil and tap changer oil. Tracks the most abrupt and fleeting variations in temperature differential and detects faults that develop more rapidly.</p>	
<p><b>Filt. Dif. Temp – Filtered temperature differential</b>            The filtered temperature differential between the transformer oil and the tap changer oil. Because it is filtered, it will be less affected by temporary situations, making it better for detecting persistent differentials and long-lasting trends in temperature difference.</p>	
<p><b>Min. Inst. Dif – Minimum instantaneous differential</b>            Displays the lowest instantaneous temperature differential since the last time this marker was reset.</p>	
<p><b>Min. Filt. Dif. – Minimum filtered differential</b>            Displays the lowest filtered temperature differential since the last time this marker was reset.</p>	
<p><b>Max. Inst. Dif. – Maximum instantaneous differential</b>            Displays the largest instantaneous temperature differential since the last time this marker was reset.</p>	
<p><b>Max. Filt. Dif. – Maximum filtered differential</b>            Displays the largest filtered temperature differential since the last time this marker was reset.</p>	
<p><b>OLTC Max. Temp. – Maximum OLTC temperature</b>            Displays the highest temperature measured at the tap changer since the last time this marker was reset.</p>	

### 4.5.1.2 Cooling group

The cooling group submenu shows the status of the cooling groups.







**Important**

In this submenu, the display of certain screens depends on the parameters configured on the web page in item [5.4.3.4.3.1](#), so some screens may not be displayed.

Table 19 - Cooling group submenu















<b>Cooling group submenu information</b>	
<p><b>Cooling Groups – Cooling group submenu</b></p> <p>Use the arrows to continue navigating through other information or press  on this screen to access the submenu and consult the secondary screens. Once inside, navigate using the arrows  and . To return to the previous level, press .</p>	
<p><b>Cool Mon. Status – Cooling group status</b></p> <p>Indicates the ongoing status of the cooling groups, whether they are learning or monitoring.</p>	
<p><b>Group 1 Current – Cooling group 1 current</b></p> <p>Indicates the ongoing current of cooling group 1.</p>	
<p><b>Group 2 Current – Cooling group 2 current</b></p> <p>Indicates the ongoing current of cooling group 2.</p>	
<p><b>Group 3 Current – Cooling group 3 current</b></p> <p>Indicates the ongoing current of cooling group 3.</p>	
<p><b>Group 4 Current – Cooling group 4 current</b></p> <p>Indicates the ongoing current of cooling group 4.</p>	
<p><b>Group 1 Max Curr – Maximum current of cooling group 1</b></p> <p>Displays the highest current for cooling group 1 since the last time this marker was reset.</p>	
<p><b>Group 2 Max Curr – Maximum current of cooling group 2</b></p> <p>Displays the highest current for cooling group 2 since the last time this marker was reset.</p>	
<p><b>Group 3 Max Curr – Maximum current of cooling group 3</b></p> <p>Displays the highest current for cooling group 3 since the last time this marker was reset.</p>	
<p><b>Group 4 Max Curr – Maximum current of cooling group 4</b></p> <p>Displays the highest current for cooling group 4 since the last time this marker was reset.</p>	

<p><b>Cooling group 'x' – Cooling group 'x'</b>          To access the cooling group screen and set it to 'Auto' or 'On', press the keys  and  simultaneously.          The  indicates the cooling group number (1/2/3/4).</p>	
---	---

### 4.5.1.3 Insulation aging

This submenu will only be displayed if the “Enable aging” parameter, located in item [5.4.3.1](#), is set to “YES.”

Table 20 - Insulation aging submenu

<b>Insulation aging submenu information</b>	
<p><b>Insulation aging – Insulation aging submenu</b>            This submenu presents the progression of insulation aging, calculated based on the temperature and load of the transformer.            Use the arrows to continue navigating through other information or press  on this screen to access the submenu and consult the secondary screens.            Once inside, navigate using the arrows  and . To return to the previous level, press .</p>	
<p><b>Winding 'x' – Winding selection</b>            This submenu contains settings for windings 1, 2, and 3. These settings are repeated for all of them.            The  indicates the number of the winding.            For example: Winding 1, Winding 2, Winding 3.            Use the arrows to continue navigating through other information or press  on this screen to access the submenu and consult the secondary screens. Once inside, navigate using the arrows  and . To return to the previous level, press .</p>	
<p><b>Remain. Lifespan – Winding life</b>            Indicates the remaining insulation life of the selected winding.</p>	
<p><b>Avg LifeLoss/Day – Loss of life</b>            Shows the average daily lifespan loss.</p>	
<p><b>Remain. Lifetime – Lifetime</b>            Displays the projection of the remaining lifespan of the insulation, in years.</p>	













## 4.5.2. Advanced regulation query

This submenu will only be displayed if the parameter “Enable regulation functionality,” located in item [5.4.1.1](#), is set to “YES.”

Table 21 - Regulation submenu

Regulation submenu information	
<p><b>Regulation – Regulation submenu</b>            This submenu presents the parameters associated with the transformer's voltage regulation functionality, with tap changer readings.            Use the arrows to continue navigating through other information or press  on this screen to access the submenu and consult the secondary screens. Once inside, navigate using the arrows  and . To return to the previous level, press .</p>	
<p><b>U pri/I pri – Voltage and current</b>            Displays the voltage and line current of the transformer.</p>	
<p><b>Freq./FPx – Frequency and power factor</b>            Displays frequency and capacitive (c) or inductive (i) power factor.             The  indicates whether the power factor is inductive or capacitive (i = inductive or c = capacitive).</p>	
<p><b>U sec/ I sec – Voltage and current in the secondary of the PT and CT</b>            Displays the voltage at the transformer PT secondary. The bottom line displays the current at the measuring CT secondary.</p>	
<p><b>Previous TAP</b>            Indicates the previous TAP measurement.</p>	
<p><b>Minimum TAP</b>            Indicates the minimum TAP measurement.</p>	
<p><b>Maximum TAP</b>            Indicates the maximum TAP measurement.</p>	
<p><b>N Oper – Number of operations</b>            Displays the number of operations already performed by the tap changer and the average daily operations.</p>	
<p><b>Oper. Since Last Maint. – Operations after the last maintenance</b>            Indicates the number of operations performed by the tap changer after the last maintenance.</p>	
<p><b>I2/ Avg.I2 – Switched current</b>            The top line displays the accumulated switched current.            The other line displays the average daily increase in switched current.</p>	
<p><b>I2 After Maint. – Switched current after last maintenance</b>            Indicates the accumulated switched current after the last maintenance.</p>	



<p><b>Warn I2/Operations - I<sup>2</sup> or operations warning</b> Indicates the number of days remaining for the I<sup>2</sup> or operation alarms, considering the I<sup>2</sup> accumulation trends or the average of ongoing daily maneuvers, respectively.</p>	
<p><b>Disable Maint. Warning – Disable maintenance notice</b> Allows the HMI to block the display of warnings that are active at the time of the command. The blocking is automatically disabled only when both warnings are also disabled. Configuration can be done on the device or via the website. Press the key  and  simultaneously, you can select the command “Disable Maint. Warning”. If you select “YES”, the warning screen will be disabled.</p>	
<p><b>LTC Maintenance performed – OLTC maintenance performed</b> The maintenance command clears maintenance alarms and resets the accumulators, both for the number of operations and the switched current per unit squared, after maintenance is performed. Configuration can be done on the device or via the website. If you select “YES” in the "Disable Maint. Warning" parameter and press the  and  keys simultaneously, the display “LTC maintenance performed” will appear.</p>	
<p><b>OLTC TAP Command</b> For SDV to be able to execute this command, it must have the following configurations:</p> <ul style="list-style-type: none"><li>✓ Operation mode setting set to local;</li><li>✓ Command mode setting set to manual;</li></ul> <p>Once these settings are applied, you will be able to access the TAP control screen by pressing the  and  keys simultaneously. Pressing the  key enables the command to raise the TAP; Pressing the  key enables the command to lower the TAP.</p>	

### 4.5.3. General advanced query













The general advanced query screen displays the device clock and network settings.



**Important**

In this submenu, the display of certain screens depends on the operating mode configured in the Network section; therefore, some screens may not be displayed.

Table 22 - General submenu

General submenu information	
<p><b>General – General submenu</b></p> <p>Use the arrows to continue navigating through other information or press  on this screen to access the submenu and consult the secondary screens. Once inside, navigate using the arrows  and . To return to the previous level, press .</p>	
<p><b>Clock</b></p> <p>This screen displays date, day of the week, time and GMT (time zone).</p> <p>If during parameterization the SDV is programmed in English, this screen will be displayed in the format mm/dd/yy. Otherwise, dd/mm/yy.</p>	
<p><b>Network Config. – Network configuration</b></p> <p>This query screen shows the SDV's primary and secondary network IP address and subnet mask, gateway, and preferred and alternate DNS.</p> <p>Use the arrows to continue navigating through other information or press  on this screen to access the submenu and consult the secondary screens. Once inside, navigate using the arrows  and . To return to the previous level, press .</p>	
<p><b>Bridge IP Address – IP address assigned to Bridge mode</b></p> <p>When configured in bridge mode, the two communication ports operate as a single network interface, acting in interconnection mode.</p>	
<p><b>Bridge Sub. Mask – Subnet mask assigned to Bridge mode</b></p> <p>When configured in bridge mode, the subnet mask becomes unique for the unified network interface.</p>	
<p><b>Bridge Gateway –Gateway assigned to Bridge mode</b></p> <p>When configured in bridge mode, there is only one gateway defined for the entire network interface.</p>	
<p><b>MAC Bd –Preferred DNS address assigned to Bridge mode</b></p> <p>When configured in bridge mode, the two ports share a single DNS server address.</p>	



<b>IP address 1</b> First SDV IP address.	<b>IP Address 1</b> 192.168.10.87
<b>Subnet mask 1</b> Subnet mask associated with the first SDV IP.	<b>Subnet Mask 1</b> 255.255.255.0
<b>Gateway 1</b> Gateway address 1.	<b>Gateway 1</b> ---
<b>MAC Address 1 – Preferred DNS address 1</b> Preferred DNS server address 1.	<b>MAC 1 14:1A:51</b> :00:00:00
<b>IP address 2</b> Second SDV IP address.	<b>IP Address 2</b> 192.168.1.87
<b>Subnet mask 2</b> Subnet mask associated with the second SDV IP.	<b>Subnet Mask 2</b> 255.255.255.0
<b>Gateway 2</b> Gateway address 2.	<b>Gateway 2</b> ---
<b>MAC Address 2 – Preferred DNS address 2</b> Preferred DNS server address 2.	<b>MAC 2 14:1A:51</b> :00:00:00
<b>IP address 3</b> Third SDV IP address.	<b>IP Address 3</b> 192.168.87.87
<b>Subnet mask 3</b> Subnet mask associated with the third SDV IP.	<b>Subnet Mask 3</b> 255.255.255.0
<b>Gateway 3</b> Gateway address 3.	<b>Gateway 3</b> ---
<b>MAC Address 3 – Preferred DNS address 3</b> Preferred DNS server address 3.	<b>MAC 3 14:1A:51</b> :00:00:00

## 4.6. Warnings

The Smart Device for Voltage Regulation (SDV) can detect and predict various faults that may occur in the transformer, tap changer, or the device itself. When these irregularities are identified, the SDV automatically displays alert messages on the device's screen. As in the example on the right, the SDV has detected a self-diagnosis and displays the self-diagnosis code for identification.



Figure 29 - Display indicating self-diagnosis



### Self-diagnosis

This screen is displayed when the IED presents internal or connection anomalies. One or more codes are displayed on the line below to identify the self-diagnosis, according to the table available in chapter 6.1 of this manual.



### Alarms

This screen is displayed when the IED identifies external anomalies. As with the self-diagnosis screen, one or more codes are displayed to identify the self-diagnosis, according to the table available in chapter 6.2 of this manual.



### Potentiometric transmitter reading error

This screen is displayed when the IED is unable to read the tap position of the potentiometric transmitter. For more details on this error, see the table in chapter 6.1 of this manual.



### Blocked OLTC I:

This screen is displayed to notify the user that the tap changer (OLTC) has been blocked due to a power flow reversal error.





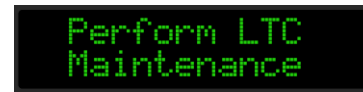

### Blocked OLTC II

This screen is displayed to warn the user that the OLTC has been blocked due to another error problem and not the inversion in the power flow.



### OLTC Maintenance Warning

This screen is displayed to notify the user that tap changer maintenance is due soon. To inform the SDV that maintenance has been performed, press  and  simultaneously, the message "OLTC Maintenance performed?" will appear on the screen, then press the key  and then  to confirm.

Perform LTC  
5 days

### Maintenance warning in days

This screen notifies the user of the need for OLTC maintenance, establishing an ideal time (in days).

Perform LTC  
IPU2 in 1 day

### High integral current sum

This screen is displayed when the sum of the integral current reaches the user-selected alarm value, indicating wear on the tap changer contacts.

Oil trip in  
00:00:30

### Oil temperature shutdown time

The user can program the timing for shutdown when the oil temperature reaches the set level. This screen indicates the time for this action.

Wind 1 trip in  
00:00:00

### Winding 1 temperature shutdown time

The user can program, via the web page, the timing for shutdown when the temperature of winding 1 reaches the programmed level. This screen indicates the time for this action.

Wind 2 trip in  
00:00:00

### Winding 2 temperature shutdown time



The user can program, via the web page, the timing for shutdown when the temperature of winding 2 reaches the programmed level. This screen indicates the time for this action.

Wind 3 trip in  
00:00:00

### Winding 3 temperature shutdown time

The user can program, via the web page, the timing for shutdown when the temperature of winding 3 reaches the programmed level. This screen indicates the time for this action.

## 4.7. SDV firmware, bootloader and other information

By pressing the  and  keys simultaneously, you can consult device information. The following data will be displayed on the device: name, firmware version, release, bootloader, and serial number. The following screens will be displayed in sequence.

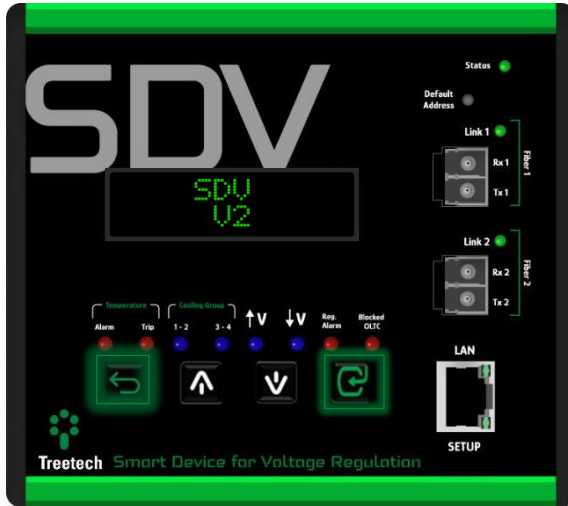

Figure 30 - Command to access equipment information



Figure 31 - Display indicating system functionality



Figure 32 - Display indicating system version



Figure 33 - Display indicating application version

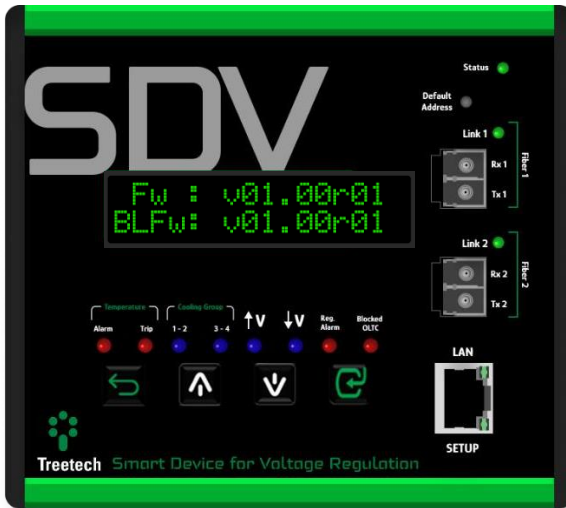

Figure 34 - Display indicating firmware and bootloader version and release



Figure 35 - Display indicating serial number

## 5. Website

Using the latest HTML5 and Bootstrap technologies, all communication management, information visualization and SDV parameter configuration are done directly on the equipment's web interface, without the need for a user license or installation of proprietary software.

To access the SDV web page, simply enter the device's IP address into a web browser that supports HTML5. For information on how to check the SDV's IP address, see section [4.5.3](#) of this manual.

### 5.1. Navigation

#### ✓ Navigation

To facilitate navigation in the SDV web interface, standardized symbology is used across various sections of the system. The display of certain fields and features may vary depending on the user's access profile, restricting views or adjustments to those with the appropriate permissions.

#### ✓ Language

The SDV web interface is available in three languages: Portuguese, English, and Spanish. Users can select their preferred language, ensuring greater accessibility and understanding of information during equipment operation and configuration.

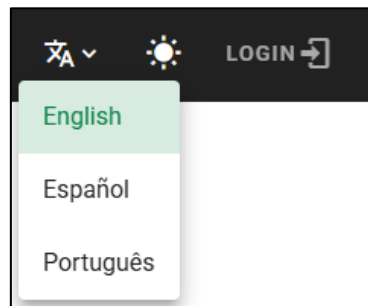

Figure 36 - Language tab

### ✓ Information

This icon provides contextual information about the page and is primarily displayed in settings areas. It's useful for clarifying quick questions while adjusting parameters.



Figure 37 - Information icon

### ✓ Status

When the SDV's internal communication quality is unstable, an icon will appear in the upper right corner of the page, indicating a communication failure or instability. If communication is stable, no icon will be displayed. This signaling contributes to quick diagnosis and greater reliability in equipment monitoring.

 **Poor communication:** Failure in communication with the equipment;

 **Unstable communication:** Unreliable communication state.

## 5.2. Log in

### Username and password

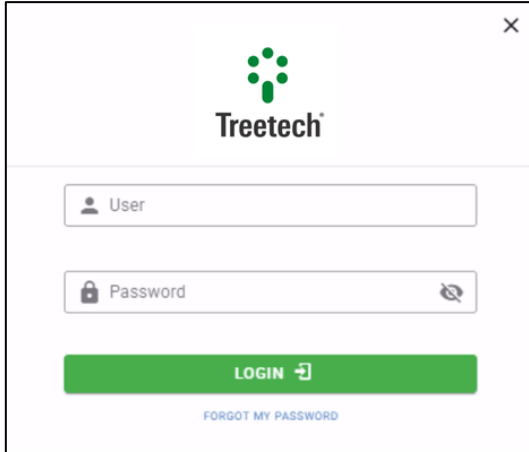

To access more IED details and acquire data online through the website, you must have a valid username and password. To do so, simply click the green "Login" button in the upper right corner of the screen.

A window will appear with fields for your username and password. After filling in the fields, simply click the green "Login" button again to access the system. The default login information is:

**Username:** default | **Password:** Default123

Figure 38 - Login screen

### User configuration

In this tab, you can configure the profile, create users and restart the equipment. It is available after login and to access it, just click on the user icon.

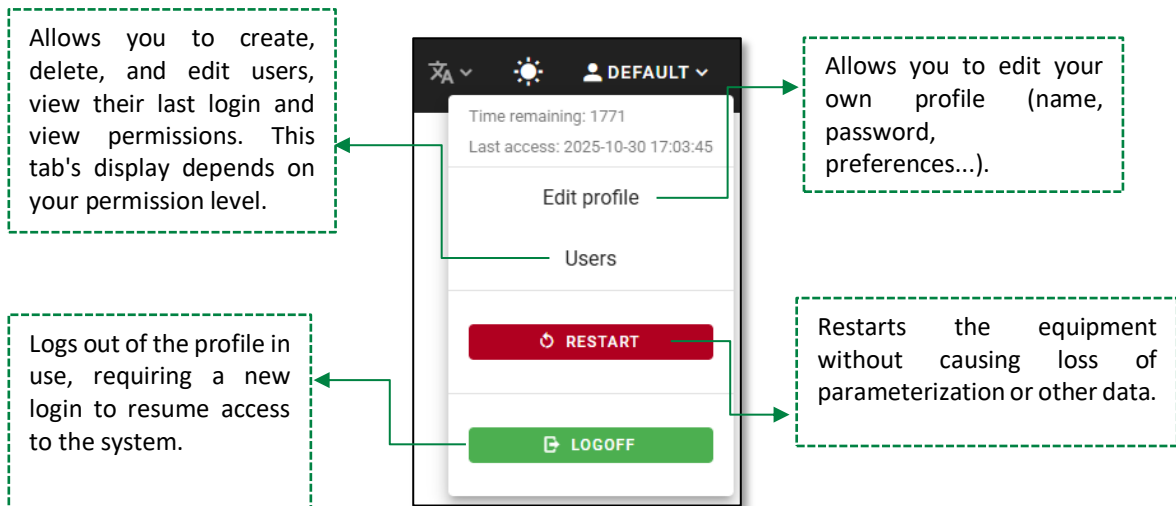
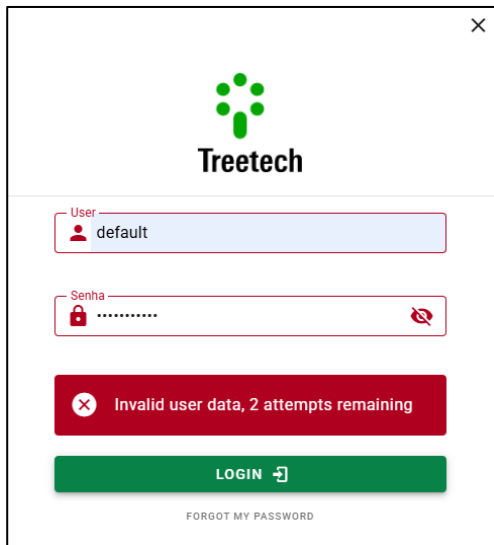

Figure 39 - User tab

## Incorrect username and/or password



If the username and/or password are incorrect, a message in a red box will be displayed informing you of the error and the number of attempts remaining.

If you exceed the number of attempts allowed (up to 3), your login will be temporarily blocked for approximately 1 minute, although you can still access it with another profile, if necessary.

Figure 40 - Incorrect username or password

## Time limit

If a user logs in but remains inactive, the session will expire after ten minutes. For the last thirty seconds, a countdown window will alert you about the session closure.



Figure 41 - Time limit

### 5.3. Online

The Online section displays configured parameters, active alarms, self-diagnosis information, and SDV measurement values in real time. It allows for continuous monitoring of the equipment's status in a convenient and centralized manner.

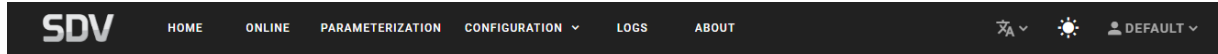

Figure 42 - Online section

In the upper right corner of this section, you can select the view template. The blocks change color depending on the Abstract's communication status. You can also switch to list view, where the status is indicated by previously displayed icons. To change the display mode, simply click on the desired template.



Figure 43 - View mode icons

#### 5.3.1. Data status

It is possible to track the status of punctual communication, as well as monitor the displayed parameters in real time, as illustrated below.



Figure 44 - Data status

### 5.3.2. Data arrangement

<span>&gt; SELF-DIAGNOSIS</span> <span>DEBUG</span> <span>GENERAL</span> <span>ALARM</span>		
<b>&gt; GENERAL</b> TEMPERATURE REGULATION CLUSTER	Description	Value
	✓ Self-diagnosis for windings 1V65 measurement	Not triggered
	✓ Self-diagnosis for communication failure between boards	Not triggered
	✓ Self-diagnosis for CT measurement of winding 1	Not triggered
	✓ Self-diagnosis for CT overflow of winding 1	Not triggered
	✓ Self-diagnosis for CT measurement of winding 2	Not triggered
	✓ Self-diagnosis for CT overflow of winding 2	Not triggered
	✓ Self-diagnosis for CT measurement of winding 3	Not triggered
✓ Self-diagnosis for CT overflow of winding 3	Not triggered	
Items per page: <input type="text" value="10"/>		1-8 of 8   << < > >>

Figure 45 - Information board

It presents the values configured for the SDV operation, covering general data, status information and specific measurements of regulation, temperature, paralleling concentrates and output relays.

The following image shows what each tab contains in the vertical part.

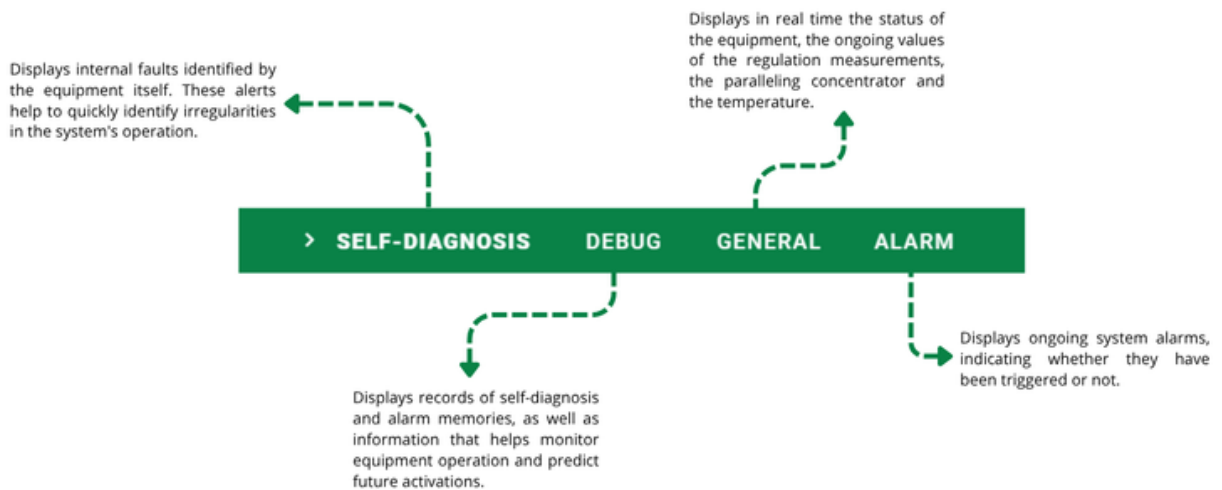

Figure 46 - Horizontal tabs of the Online tab

## 5.4. Parameterization

In the parameterization section, the user can access the configuration tabs: “General”, “Transformer”, “Temperature”, “Regulation” and “Relays”.

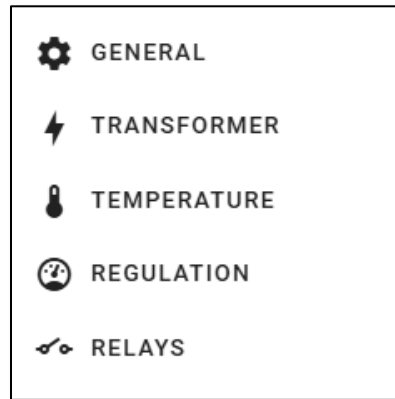

Figure 47 - Configuration tabs

In this interface, the parameters are organized in a structured way, allowing the visualization and configuration of values related to the transformer, temperature control, regulation system, output relays and general system data.

### Sending parameters

For a parameter change to take effect in SDV, you must click the "Submit" button on each screen where the modification is made. The system saves parameters individually per screen, not globally. This means that if you navigate to a new tab without clicking "Submit," any changes made previously will not be saved.



Figure 48 - Submit button

### Parameter validation

All changes must comply with the previously defined limits for each parameter. If the entered value is outside the permitted range, the system will not allow the configuration to be sent. This validation prevents operational errors and ensures the safety and stability of the equipment.

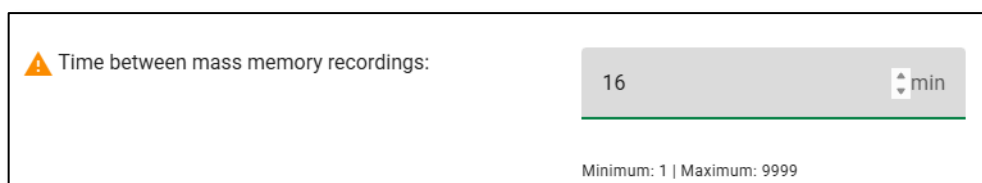

Figure 49 - Value outside the determined range

**⚠** This warning will be displayed whenever there is an unconfirmed parameter change. The notice will disappear automatically after submitting the change using the “Submit” button.

## 5.4.1. General

### 5.4.1.1. Basic



Figure 50 - General → Basic

### Reset parameters to default values

This parameter allows you to restore all system values to factory default settings.

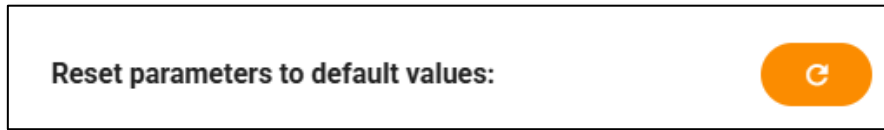



Figure 51 - Reset to default value button

When you click the button , a confirmation message will appear asking if you really want to reset the values. To proceed, enter the password you used to log in to the website.

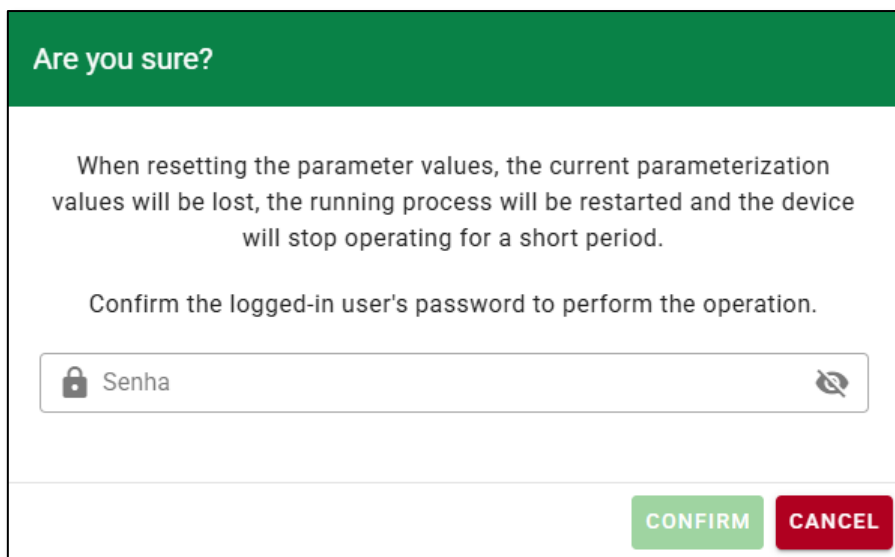

Figure 52 - Confirmation message

### Enable temperature functionality



Enables temperature functionality.

**Note:** If the 'NO' option is activated, item [5.4.3](#) regarding temperature will not be displayed.

**Adjustment range:** YES, NO.

**Default value:** YES.

### Enable regulation functionality

Enables the regulation functionality.

**Note:** If the 'NO' option is activated, item [5.4.4](#) regarding regulation will not be displayed.

**Adjustment range:** YES, NO.

**Default value:** YES.

### Screen selection during rest

Select whether, during normal operation, the device will always display the same information, or whether the main information will be presented cyclically, with a few seconds between each. If not specified, the device will display the last screen viewed.

**Adjustment range:** No specific screen, scrolling screens, default screens.

**Default value:** No specific screen.

### Time to activate screen saver

Select the amount of time for the device to return to the home screen when not in use. After this time, the IED will also automatically reduce the screen brightness to save power.

**Adjustment range:** 1 to 15 minutes.

**Default value:** 5 minutes.

### Time between mass memory writes

User programming of the interval between mass memory writes.

**Adjustment range:** 1 to 9999 minutes.

**Default value:** 60 minutes.

### Oil temperature variation limit for mass memory recording

User programming of oil temperature variation limit for mass memory recording.

**Adjustment range:** 1 to 20°C.

**Default value:** 5°C.

### 5.4.1.2. Commands

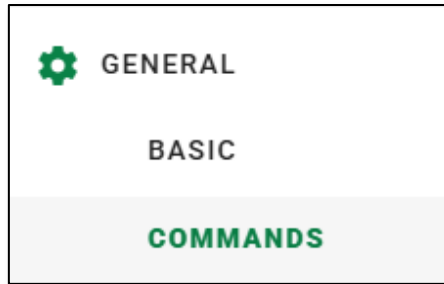

Figure 53 - General → Commands

#### Self-diagnosis memory reset

Self-diagnosis memory reset command.

**Adjustment range:** No command, perform reset.

**Default value:** No command.

#### Alarm memory reset

Alarm memory reset command.

**Adjustment range:** No command, perform reset.

**Default value:** No command.

#### Mass memory reset

Mass memory reset command.

**Adjustment range:** No command, perform reset.

**Default value:** No command.

## 5.4.2. Transformer

### 5.4.2.1. Basic

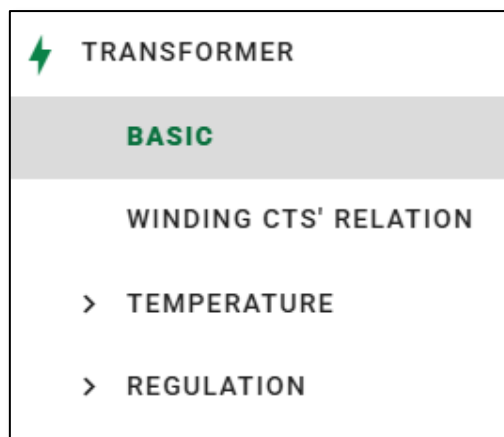

Figure 54 - Transformer → Basic

### Transformer type

Select the type of monitored transformer between three-phase and single-phase.

**Adjustment range:** Single-phase, three-phase.

**Default value:** Three-phase.

### Inversion of the clip-on CT

Parameterize the connection polarity of the CT selected for regulation (1, 2 or 3).

**Adjustment range:** Normal, inverted.

**Default value:** Normal.

### CT/PT phase shift

There are several possible combinations for connecting the PT and CT to the SDV, and each combination produces an angular phase shift between the voltage and current signals. This parameter adjusts the phase shift angle between the voltage measured by the PT and the current measured by the CT. This value will be used to correctly calculate the power factor.

**Adjustment range:** 0°, 30°, 60°, 90°, 120°, 150°, 180°, 210°, 240°, 270°, 300° and 330°;

**Default value:** 0°.

### Nominal power

To calculate the transformer loading percentage, it is necessary to inform the SDV of the nominal power of the transformer (or transformer bank).

**Adjustment range:** 0.0 to 999.9 MVA.

**Default value:** 10.0 MVA.

### Nominal current

To calculate the transformer loading percentage, it is necessary to inform the SDV of the nominal current of the transformer (or transformer bank).

**Adjustment range:** 0.01 to 655.35 kA.

**Default value:** 5.00 kA.

### 5.4.2.2. Winding CTS' Relation

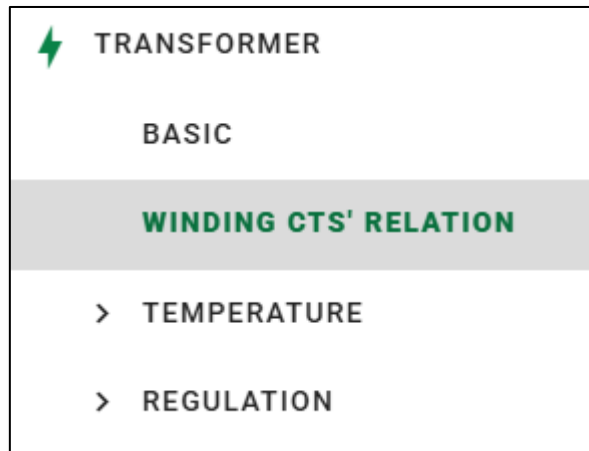

Figure 55 - Transformer → Winding CTS' Relation



The following parameters contain settings for the CT ratios 1, 2, and 3 (indicated by “x”). These settings are repeated for all of them.

#### CT ‘x’ ratio

Parameterize the ratio of the auxiliary CT used for voltage measurement by the SDV.

**Adjustment range:** 1 to 10000.

**Default value:** 3030.

### 5.4.2.3. Temperature

#### 5.4.2.3.1. Cooling CTS' Relation

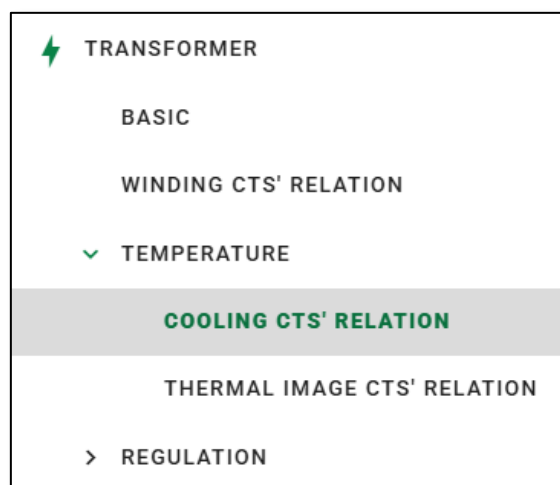

Figure 56 - Temperature → Cooling CTS' Relation



The following parameters contain settings for the TC ratios of cooling groups 1, 2, 3, and 4 (indicated by “x”). These settings are repeated for all of them.

### CT ratio of cooling group ‘x’

Parameter for setting the transformation ratio of the cooling group CT input.

**Adjustment range:** 1 to 65535.

**Default value:** 3030.

#### 5.4.2.3.2. Thermal image CTS’ Relation

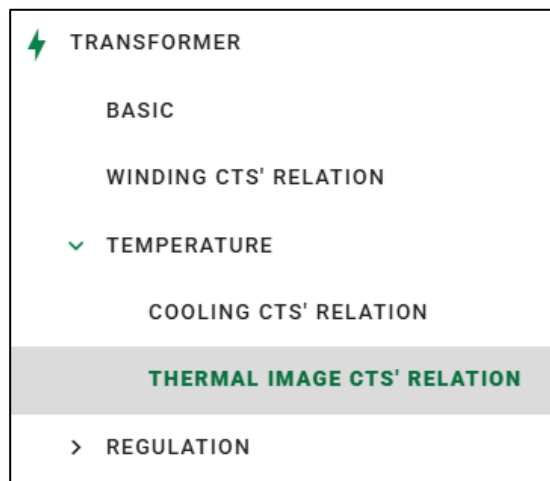

Figure 57 - Temperature → Thermal Image CTS’ Relation



The following parameters contain settings for the CT ratio of windings 1, 2, and 3 (indicated by “x”) for thermal imaging. These settings are repeated for all of them.

### CT ratio of winding ‘x’ for thermal imaging

Parameterize the thermal image CT transformation ratio of winding 'x'.  $CT\ Ratio = \frac{CT\ Primary\ Current}{CT\ Secondary\ Current}$ .

x = 1, 2 or 3.

**Adjustment range:** 1 to 9999.

**Default value:** 500.

#### 5.4.2.4. Regulation

##### 5.4.2.4.1. PT/Line CT ratio

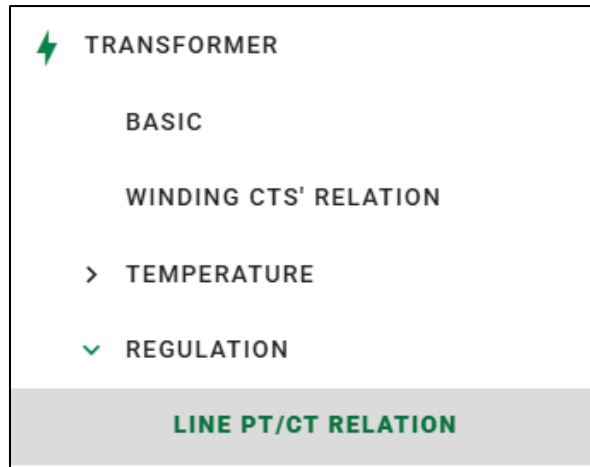

Figure 58 - Regulation → PT/Line CT ratio

#### PT ratio

Adjustment of the transformation ratio of the measuring PT being obtained by dividing the voltage in the primary winding of the PT by the voltage in the secondary winding.

Example:

Considering the voltage of the primary winding of the PT being equal to 138 kV and the voltage of the secondary winding equal to 115 V, we arrive at the value of the voltage ratio of the PT:

$$\text{PT ratio} = \frac{138000 \text{ V}}{115 \text{ V}} = 1200$$

**Adjustment range:** 1 to 9999.

**Default value:** 100.

#### CT ratio

Adjustment of the transformation ratio of the measuring CT, obtained by dividing the CT primary winding current by the secondary current.

Example:

Considering the current of the primary winding of the CT being equal to 250 A and the secondary current equal to 5 A, we arrive at the value of the current ratio of the CT:

$$\text{CT ratio} = \frac{250 \text{ A}}{5 \text{ A}} = 50$$

**Adjustment range:** 1 to 9999.

**Default value:** 100.

### 5.4.3. Temperature

This tab will only be displayed if the “Enable temperature functionality” parameter, located in item [5.4.1.1](#), is set to “YES”.

#### 5.4.3.1. Basic

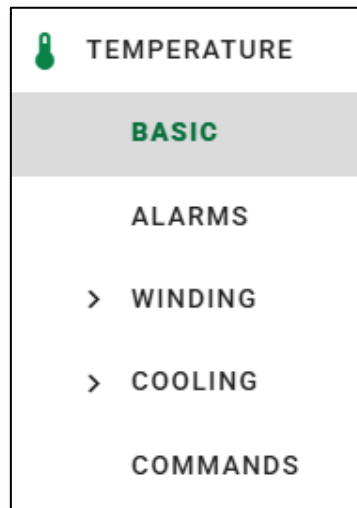

Figure 59 - Temperature → Basic



The following parameters contain settings for activating temperature sensor 1, 2, and 3 (indicated by “x”). These settings are repeated for all of them.

#### Enable temperature sensor ‘x’

Choose to turn Pt100 temperature sensor 'x' on or off (1 to 3). Later, you can assign functions to the temperature sensors. If the sensor is already assigned to a function, it cannot be disabled. If it is active but not assigned to any function, it will measure the ambient temperature.

**Adjustment range:** YES, NO.

**Default value:** NO.

#### Select first sensor for oil temperature

Select the sensor to be used to measure the transformer oil temperature. Only sensors that are not already assigned to another task will appear as options.

**Adjustment range:** None, PT100 1, PT100 2, PT100 3.

**Default value:** PT100 1.

#### Select redundant sensor for oil temperature

Select the second sensor to be used to measure the transformer oil temperature if you want



to create measurement redundancy. Only sensors that are not already assigned to another task will appear as options.

**Adjustment range:** None, PT100 1, PT100 2, PT100 3.

**Default value:** None.

### Maximum temperature difference between redundant sensors

Set the maximum acceptable difference between the temperatures measured by the redundant sensors. If the difference between the measurements exceeds this value, the "Maximum temperature difference between redundant sensors" self-diagnosis will be generated, which will be displayed in the "Home" or "Online" section.

This parameter will be displayed if a PT100 sensor is associated in "Select redundant sensor for oil temperature", located in the previous parameter.

**Adjustment range:** 1.0 to 6.0 °C.

**Default value:** 4.0 °C.

### Temperature sensor selection for the tap changer

Select the sensor to be used to measure the tap changer temperature. Only sensors that are not already assigned to another task will appear as options.

**Adjustment range:** None, PT100 1, PT100 2, PT100 3.

**Default value:** None.

### Hot-spot factor type

Choose the standard whose methodology will be adopted to calculate the temperature of the windings, especially with regard to the hot spot:

- ANSI IEEE C57.91:2011; ABNT NBR 5416:1997;
- IEC 60076-7:2018; ABNT NBR 5356-7:2017.

**Adjustment range:** ANSI, IEC.

**Default value:** ANSI.

### Setting the number of available windings

In this parameter, user can adjust the value according to the number of windings of the transformer.

**Adjustment range:** 1, 2, 3.

**Default value:** 1.

### Enable aging

Activates the aging monitoring function.

**Adjustment range:** YES, NO.

Default value: NO.

### 5.4.3.2. Alarms

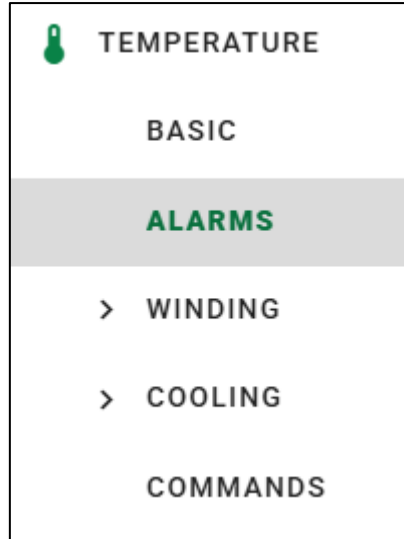

Figure 60 - Temperature → Alarms

## OIL

### Alarm due to oil temperature

Alarm trigger temperature due to high oil temperature. Once triggered, the alarm is only deactivated if the temperature drops 1°C or more below the trigger value.

**Adjustment range:** -55 to 200 °C.

**Default value:** 95 °C.

### Oil temperature shutdown

Transformer shutdown temperature due to high oil temperature. Once triggered, the shutdown signal is only deactivated if the temperature drops 1°C or more below the trigger value.

It can also be used as a second-level alarm if automatic shutdown of the transformer is not desirable.

**Adjustment range:** -55 to 200°C.

**Default value:** 105 °C.

### Oil temperature shutdown delay

Allows you to insert a delay between the moment the oil temperature reaches the shutdown value and the moment the shutdown signal and the associated output relays are actually activated.



**Adjustment range:** 0.0 to 20.0 minutes.

**Default value:** 20.0 minutes



The following parameters contain settings for windings 1, 2, and 3 (indicated by “x”). These settings are repeated for all of them.

**Note:** To view the parameters of windings 2 and 3, access the [“Setting the number of available windings”](#) parameter and set it to 3 windings.

## WINDING ‘x’

### Alarm due to winding ‘x’ temperature

Alarm trigger temperature due to high winding 'x' temperature. Once triggered, the alarm is only deactivated if the temperature drops 1°C or more below the trigger value.

**Adjustment range:** -55 to 200 °C.

**Default value:** 105 °C.

### Winding ‘x’ temperature shutdown

Transformer shutdown temperature due to high winding 'x' temperature. Once triggered, the shutdown signal is only deactivated if the temperature drops 1°C or more below the trigger value.

It can also be used as a second-level alarm if automatic shutdown of the transformer is not desirable.

**Adjustment range:** -55 to 200 °C.

**Default value:** 120 °C.

### Winding ‘x’ temperature shutdown delay

Allows you to insert a delay between the moment the temperature of winding ‘x’ reaches the value for shutdown and the instant the shutdown signal and the associated output relays are actually activated.

**Adjustment range:** 0.0 to 20.0 minutes.

**Default value:** 20.0 minutes.

## 5.4.3.3. Winding

To view the parameters for windings 2 and 3, access the [“Setting the number of available windings”](#) parameter and set it to 3 windings.

### 5.4.3.3.1. Winding 'x'

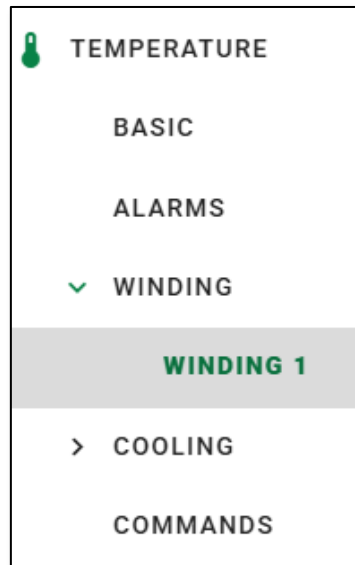

Figure 61 - Temperature → Winding 'x'



The following parameters contain settings for windings 1, 2, and 3 (indicated by "x"). These settings are repeated for all of them.



Cooling stage 0, 1, 2, 3, 4 (Indicated by 'y'):

- 0 - Sets the parameters for calculating temperature increases when no forced cooling stage is activated;
- 'y' (0, 1, 2, 3, 4) - Sets the parameters for calculating temperature increases when forced cooling stage 'y' is in operation.

#### Thermal constant of winding 'x'

Time constant in seconds, related to the thermal inertia of the transformer/reactor winding. This parameter is usually obtained by the transformer/reactor manufacturer during heating tests or by calculation. If it is not possible to obtain it by either of these two methods, the typical value of 300 s may be adopted.

**Adjustment range:** 72 to 999 s.

**Default value:** 300 s.

#### Hot-spot factor of winding 'x' (cooling stage 'y')

Hot-spot factor according to the model adopted by ANSI IEEE C57.91:2011 and ABNT NBR 5416:1997 (HS+) standards or by IEC 60076-7:2018 and ABNT NBR 5356-7:2017 (HS\*)

standards. In the first case, it is the difference between the temperature of the hottest point (hotspot) and the average winding temperature. According to the IEC standard, it is the ratio of the temperature rise of the hottest point over the top oil temperature to the rise of the average winding temperature over the average oil temperature.

**Adjustment range:** 0.00 to 20.00.

**Default value:** 1.00.

### Exponent 2M of the winding 'x' (cooling stage 'y')

Exponent used to calculate winding temperature rise as a function of copper losses, defined by the type of transformer oil circulation. The value selection is flexible, but some notable numbers stand out:

Table 23 - Winding exponent - IEC

Winding exponent - IEC 60076-7:2018 and ABNT NBR 5356-7:2017 standards		
	Number	Description
Distribution transformers	1,6	Transformers cooled by natural or forced oil circulation (ONAN, ONAF, OFAF, OFWF)
Large and medium-sized power transformers	1,3	Transformers cooled by natural or forced oil circulation (ONAN, ONAF, OFAF, OFWF)
	2,0	Transformers cooled by directed circulation in oil (ODAF, ODWF)

Table 24 - Winding exponent - ABNT

Expoente do enrolamento - Normas ABNT NBR 5416:1997 e IEEE C57.91:2011	
Number	Description
1,6	Transformers cooled by natural or forced oil circulation (ONAN, ONAF, OFAF, OFWF)
2,0	Transformers cooled by directed circulation in oil (ODAF, ODWF)

**Adjustment range:** 0.0 to 4.0.

**Default value:** 1.6.

### Winding 'x' gradient (cooling stage 'y')

Winding-to-oil temperature gradient, defined by IEC 60076-7:2018/NBR 5356-7:2017 as the difference between the average winding temperature and the average oil temperature, after thermodynamic stabilization of the transformer at nominal load, and by NBR 5416:1997/IEEE C57.91:2011 as the increase in the average winding temperature relative to the top oil temperature, after thermodynamic stabilization of the transformer at nominal load. This parameter is generally obtained by the transformer/reactor manufacturer in heating tests or by calculation.

**Adjustment range:** 0.0 to 50.0 °C.

**Default value:** 10.0°C.

### Nominal current of winding 'x' (cooling stage 'y')

Current in the transformer/reactor winding during measurement of temperature rise parameters (GEO, HS+ and HS\*). Corresponds, in general, to the nominal current of the transformer/reactor.

**Adjustment range:** 0.000 to 99.990 kA.

**Default value:** 1.670 kA.

#### 5.4.3.4. Cooling

##### 5.4.3.4.1. Configuration

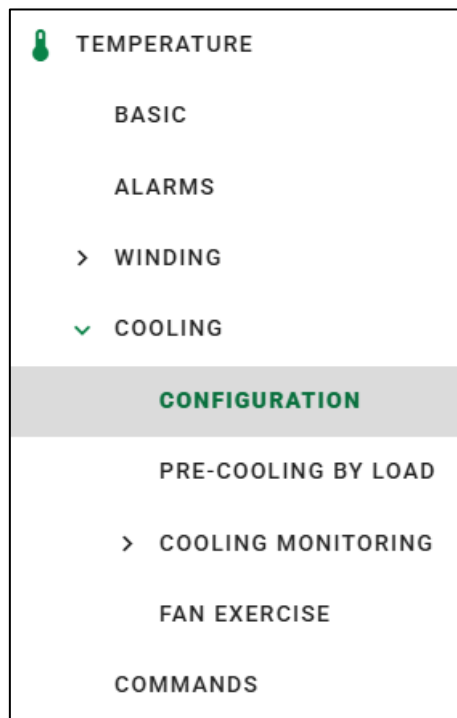

Figure 62 - Cooling → Configuration

#### Configuration of number of cooling groups

Select the number of cooling groups you want to activate.

**Adjustment range:** 1 to 4.

**Default value:** 2.

#### Temperature hysteresis for shutdown of cooling groups

Temperature reduction value, below the cooling stage start temperature, to turn off the fans/pumps, to prevent them from being switched on and off repeatedly with small temperature variations.

**Adjustment range:** 0 to 30 °C.

**Default value:** 5 °C.

#### Temperature for cooling pump blocking



Temperature below which oil pump operation must be blocked to avoid the risk of static electrification from very cold oil. This parameter will only be displayed if one of the cooling groups is configured as "Pump."

**Adjustment range:** -55 to 200 °C.

**Default value:** -25 °C.

### Stage 1 temperature for cooling

Temperature to activate forced cooling stage 1 (oil or winding temperature). The set will be turned on when the stage associated with it is reached.

**Adjustment range:** -55 to 250°C.

**Default value:** 65°C.

### Stage 2 temperature for cooling

Temperature to activate forced cooling stage 2 (oil or winding temperature). The set will be turned on when the stage associated with it is reached.

**Adjustment range:** -55 to 250°C.

**Default value:** 70°C.

### Stage 3 temperature for cooling

Temperature to activate forced cooling stage 3 (oil or winding temperature). The set will be turned on when the stage associated with it is reached.

**Adjustment range:** -55 to 250°C.

**Default value:** 75°C.

### Stage 4 temperature for cooling

Temperature to activate forced cooling stage 4 (oil or winding temperature). The set will be turned on when the stage associated with it is reached.

**Adjustment range:** -55 to 250°C.

**Default value:** 80°C.

Cooling stage group registration table

Group	Stage 1	Stage 2	Stage 3	Stage 4
1	<input type="checkbox"/>	<input type="checkbox"/>	<input type="checkbox"/>	<input type="checkbox"/>
2	<input type="checkbox"/>	<input type="checkbox"/>	<input type="checkbox"/>	<input type="checkbox"/>
3	<input type="checkbox"/>	<input type="checkbox"/>	<input type="checkbox"/>	<input type="checkbox"/>
4	<input type="checkbox"/>	<input type="checkbox"/>	<input type="checkbox"/>	<input type="checkbox"/>

Figure 63 - Group registration table



The following parameters contain settings for cooling groups 1, 2, 3, and 4 (indicated by “x”). These settings are repeated for all of them.

### Group ‘x’

#### Manual activation of cooling group ‘x’

Defines whether the group remains on (manually) or is turned on automatically.

**Adjustment range:** Always on, automatic.

**Default value:** Always on.

#### Cooling group ‘x’ type

Indicates whether cooling group 'x' has oil pumps or just fans. The operation of group 'x' will be blocked if it has pumps and the oil temperature is below the limit selected in the [“Temperature for cooling pump blocking”](#) parameter.

**Adjustment range:** Fan, pump.

**Default value:** Fan.

#### Reference temperature for controlling cooling stage ‘x’

Indicates whether, in automatic mode, the cooling stage should be controlled by the top oil temperature or by the winding temperature.

**Adjustment range:** Winding, oil.

**Default value:** Winding.

#### 5.4.3.4.2. Pre-cooling by load

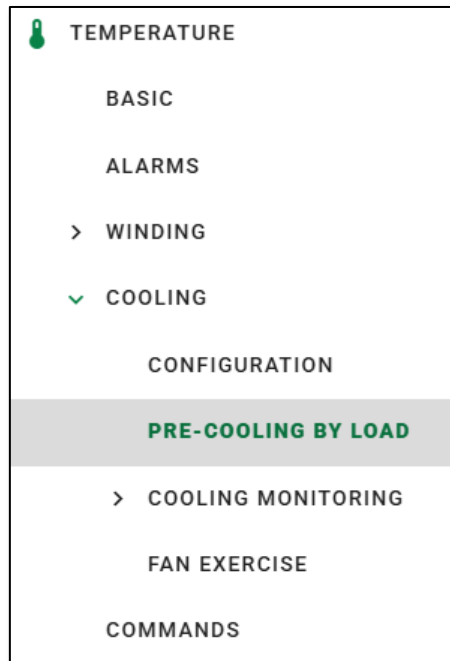

Figure 64 - Temperature → Pre-cooling by load

##### Stage 1 load for cooling

Load percentage to activate stage 1 for cooling.

**Adjustment range:** 50 to 200%.

**Default value:** 65%.

##### Stage 2 load for cooling

Load percentage to activate stage 2 for cooling.

**Adjustment range:** 50 to 200%.

**Default value:** 70%.

##### Stage 3 load for cooling

Load percentage to activate stage 3 for cooling.

**Adjustment range:** 50 to 200%.

**Default value:** 75%.

##### Stage 4 load for cooling

Load percentage to activate stage 4 for cooling.

**Adjustment range:** 50 to 200%.

**Default value:** 80%.

## Load hysteresis for shutdown of cooling groups

Load percentage reduction value, below the cooling stage start percentage, to turn off the fans/pumps, preventing them from being switched on and off successively with small load variations.

**Adjustment range:** 0 to 9%.

**Default value:** 5%.

### 5.4.3.4.3. Cooling monitoring

#### 5.4.3.4.3.1. Configuration

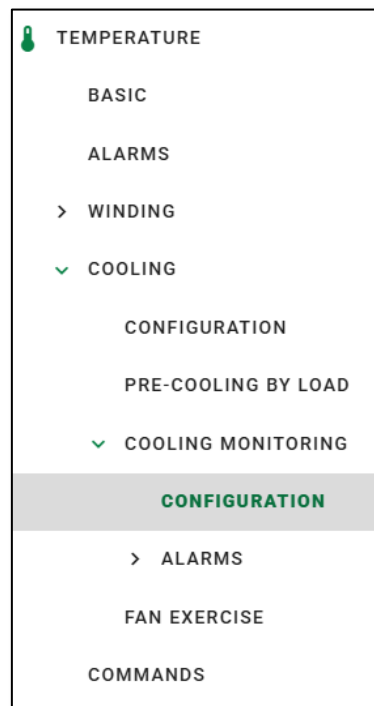

Figure 65 - Cooling monitoring → Configuration

### General enabling of learning of group alarms

Allows you to start (YES) or stop (NO) the "General enabling of learning of group alarms". Selecting YES will start the countdown for the automatic learning time, as configured in the "Timing for triggering of group monitoring alarms" parameter in topic [5.4.3.4.3.2.1](#).

**Adjustment range:** YES, NO.

**Default value:** NO.



The following parameters contain settings for cooling groups 1, 2, 3, and 4 (indicated by "x"). These settings are repeated for all of them.

### Enable current monitoring of cooling group 'x'

In this parameter, you can activate current monitoring.

**Adjustment range:** YES, NO.

**Default value:** NO.

### Reset maximum current of group 'x'

This parameter resets the current maximum value.

**Adjustment range:** No command, perform reset.

**Default value:** No command.

#### 5.4.3.4.3.2. Alarms

This tab will only be displayed if the parameter "Enable current monitoring of cooling group 'x'", located in item [5.4.3.4.3.1](#), is set to "YES".

##### 5.4.3.4.3.2.1. Parameterization

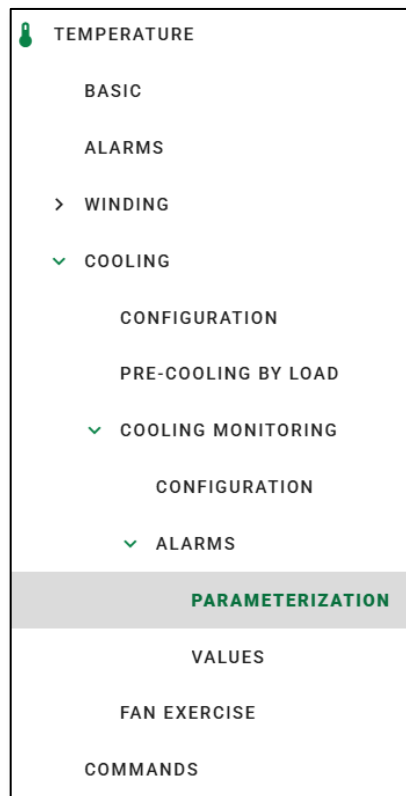

Figure 66 - Alarms → Parameterization

### Timing for triggering of group monitoring alarms

Alarms are triggered based on a time criterion. This means that the current must remain outside the established limits for a period longer than the one defined in this parameter for the alarm to be activated.

**Adjustment range:** 5 to 900 seconds.  
**Default value:** 10 seconds.

### Hysteresis to disable group monitoring alarms

For the alarm to be deactivated, the current must be within the alarm limits, considering the hysteresis percentage configured in this parameter.

**Adjustment range:** 1.0 to 10.0%.  
**Default value:** 3.0%.

### Longer start-up time between cooling groups

Time that alarms will not be checked after the cooling group is activated.

**Adjustment range:** 5 to 600 seconds.  
**Default value:** 5 seconds

### Timing for automatic learning of group monitoring alarms

Time for automatic learning of the cooling group monitoring alarm.

**Adjustment range:** 10 to 300 seconds.  
**Default value:** 30 seconds.

### Tolerance margin for automatic adjustment of group monitoring alarms

Tolerance margin considered for automatic alarm configuration.

**Adjustment range:** 1.0 to 100%.  
**Default value:** 10%.



The following parameters contain settings for monitoring groups 1, 2, 3, and 4 (indicated by “x”). These settings are repeated for all of them.

### Clearing monitoring alarms for group ‘x’

Clear alarms that are not currently being checked.

**Adjustment range:** YES, NO.  
**Default value:** NO.

### 5.4.3.4.3.2.2. Values

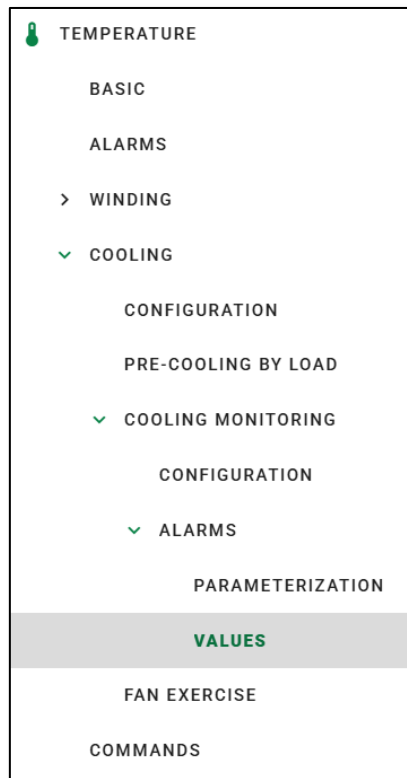

Figure 67 - Alarms → Values



The following parameters contain settings for cooling groups 1, 2, 3, and 4 (indicated by “x”). These settings are repeated for all of them.

#### Group ‘x’

##### Maximum current of group ‘x’ for alarm due to high current

Indicates the maximum current limit of group ‘x’ for the alarm due to high current.

**Adjustment range:** 0.0 to 500.0 A.

**Default value:** 10.0 A.

##### Minimum current of group ‘x’ for alarm due to low current

Indicates the minimum current limit of group ‘x’ for the alarm due to low current.

**Adjustment range:** 0.0 to 500.0 A.

**Default value:** 10.0 A.

##### Group ‘x’ current for alarm due to improper triggering

Indicates the current limit of group 'x' for the alarm due to improper triggering.

**Adjustment range:** 0.0 to 500.0 A.

**Default value:** 10.0 A.

#### 5.4.3.4.4. Fan exercise

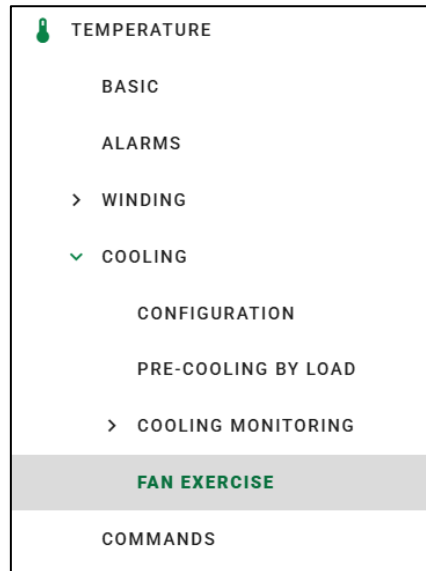

Figure 68 – Fan exercise

#### Fan exercise - Hour

Adjusting the hour at which the forced cooling groups will be activated for the daily operation of the fans and/or pumps.

**Adjustment range:** 0 to 23 hours.

**Default value:** 22 hours.

#### Fan exercise - Minutes

Adjustment of the minute (complement to the time selected in the previous parameter) in which the forced cooling groups will be activated for the daily operation of the fans and/or pumps.

**Adjustment range:** 0 to 59 minutes.

**Default value:** 30 minutes.

#### Fan exercise - Duration

Adjusts the total daily time that forced cooling units should remain activated for fan or pump operation. If it is necessary to disable the Daily Ventilation Activation function, simply set this parameter to zero.

**Adjustment range:** 0 to 999 minutes.

**Default value:** 45 minutes.

### 5.4.3.5. OLTC temperature differential

This tab will only be displayed if the “Enable temperature sensor ‘x’” parameter, located in item [5.4.3.1](#), is set to “YES” and then a PT100 sensor is selected in the “Temperature sensor selection for the tap changer” parameter.

#### 5.4.3.5.1. Configuration

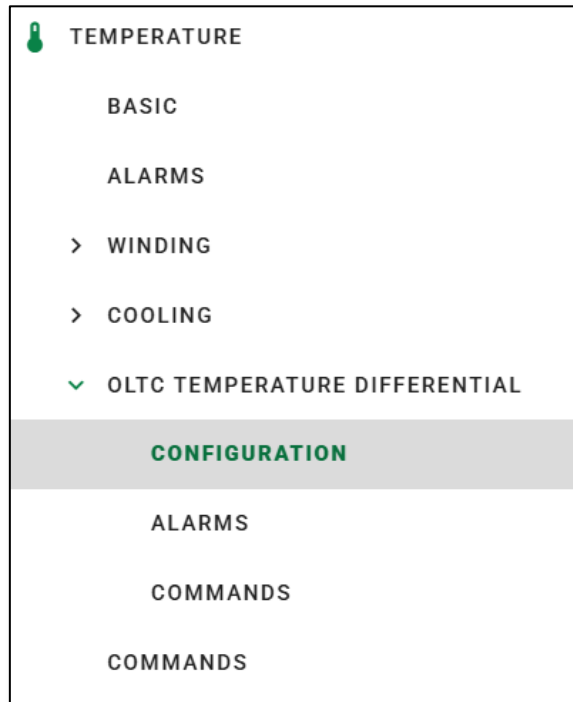

Figure 69 - OLTC temperature differential → Configuration

#### Enable automatic learning of OLTC temperature differential alarms

Allows you to start (YES) or stop (NO) the automatic adjustment process for the instantaneous and filtered temperature differential alarms. When selecting "YES", the countdown for the automatic learning time will begin, as configured in the "Timing for automatic learning of OLTC temperature differential alarms" parameter.

**Adjustment range:** YES, NO.

**Default value:** NO.

#### Timing for automatic learning of OLTC temperature differential alarms

Total time for automatic learning of alarms due to instantaneous and filtered temperature differential.

**Adjustment range:** 1 to 720 hours.

**Default value:** 336 hours

#### Temperature margin for automatic learning of alarms

Safety margin added to the largest recorded difference between tap changer and transformer temperatures during the automatic learning period. Used to set the alarm threshold.

**Adjustment range:** 1 to 10°C.

**Default value:** 5°C.

#### 5.4.3.5.2. Alarms

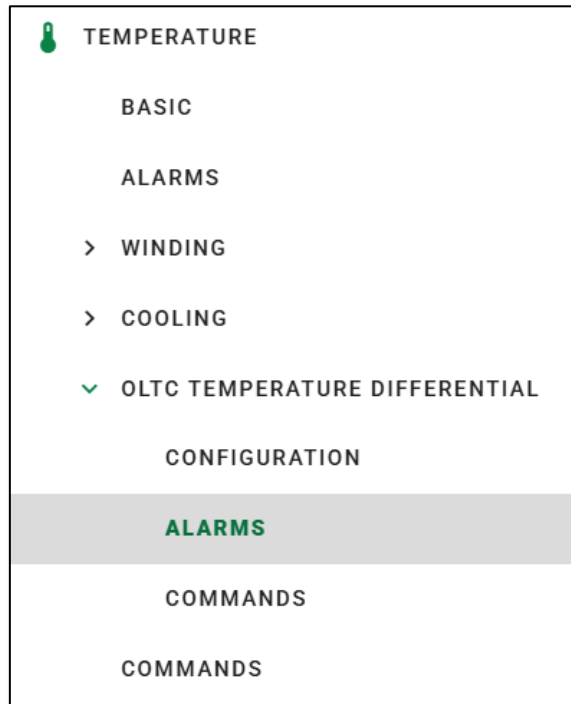

Figure 70 - OLTC temperature differential → Alarms

#### Time for OLTC temperature differential alarms

Time to issue alarms due to temperature differential of tap changers.

**Adjustment range:** 1 to 240 minutes.

**Default value:** 20 minutes.

#### Alarm due to OLTC instantaneous temperature differential

Instantaneous temperature differential between the transformer and the tap changer above which the “Alarm due to high instantaneous temperature differential” (alarm panel 3, code 1000) should activate.

**Adjustment range:** -40.0 to 40.0°C.

**Default value:** 10.0°C.

#### Alarm due to OLTC filtered temperature differential

Filtered temperature differential between the transformer and the tap changer above which the “Alarm due to high filtered temperature differential” (alarm panel 2, code 2000) should activate.

**Adjustment range:** -40.0 to 40.0°C.

**Default value:** 10.0°C.

### Time constant for filtering the temperature differential

Time constant for filtering the OLTC temperature differential to form the filtered differential.

**Adjustment range:** 0 to 720 minutes.

**Default value:** 180 minutes.

#### 5.4.3.5.3. Commands

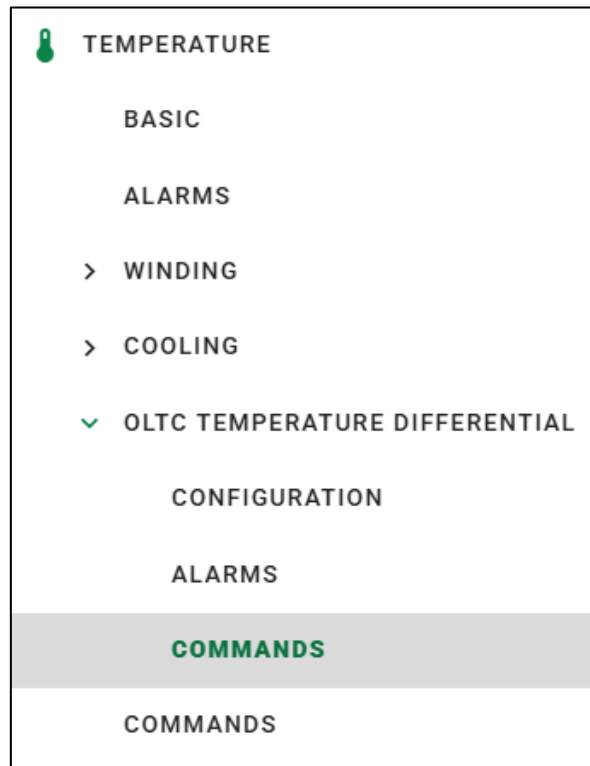

Figure 71 - OLTC temperature differential → Commands

### Reset the minimum temperature of the instantaneous differential

Resets the minimum temperature value of the instantaneous differential. After this reset, the query screen will display the new minimum temperature recorded from that moment onwards, considering only the measurements taken after the restart.

**Adjustment range:** No command, perform reset.

**Default value:** No command.

### Reset the minimum temperature of the filtered differential

Resets the minimum temperature value of the filtered differential. After this reset, the query screen will display the new minimum temperature recorded from that moment onwards, considering only the measurements taken after the restart.



**Adjustment range:** No command, perform reset.

**Default value:** No command.

#### Reset the maximum temperature of the instantaneous differential

Resets the maximum temperature value of the instantaneous differential. After this reset, the query screen will display the new maximum temperature recorded from that moment onwards, considering only the measurements taken after the restart.

**Adjustment range:** No command, perform reset.

**Default value:** No command.

#### Reset the maximum temperature of the filtered differential

Resets the maximum temperature value of the filtered differential. After this reset, the query screen will display the new minimum temperature recorded from that moment on, considering only the measurements taken after the restart.

**Adjustment range:** No command, perform reset.

**Default value:** No command.

#### Reset the maximum temperature of tap changer oil

Resets the maximum oil temperature value of the tap changer. After this reset, the query screen will display the new maximum temperature recorded from that moment on, considering only the measurements taken after the restart.

**Adjustment range:** No command, perform reset.

**Default value:** No command.

#### 5.4.3.6. Aging

This tab will only be displayed if the “Enable aging” parameter, located in item [5.4.3.1](#), is set to “YES”.

### 5.4.3.6.1. Configuration

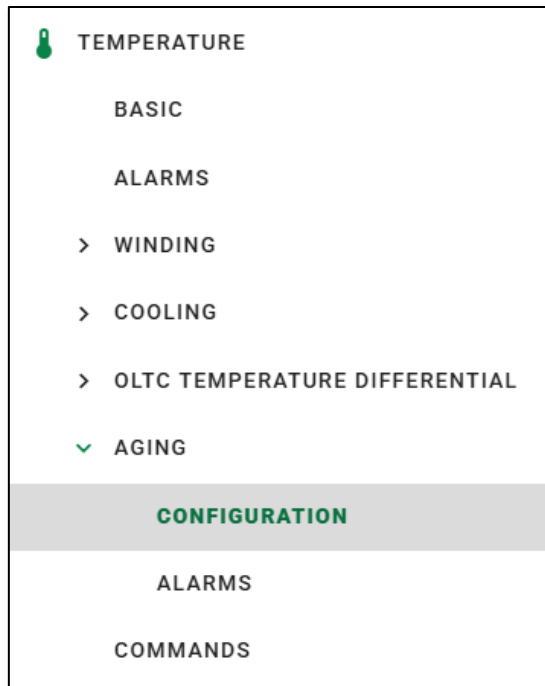

Figure 72 - Aging → Configuration

#### Reset aging calculations

Reset parameter for aging calculations.

**Adjustment range:** No command, perform reset.

**Default value:** No command.

#### Criteria for end of insulation life

Choose the insulation end-of-life criterion. The IEEE/IEC standard offers the last four criteria for end-of-life assessment, and the first comes from NBR.

**Adjustment range:**

- NBR 5416-1997;
- 50% Ultimate Tensile Strength;
- 25% Ultimate Tensile Strength;
- Degree of Polymerization 200;
- Functional Life Test.

**Default value:** NBR 5416-1997.

#### Time for aging calculation

Time constant for calculating the rate of loss of life and extrapolating the remaining lifespan.



**Adjustment range:** 1 to 30 days.

**Default value:** 7 days.



The following parameters contain settings for windings 1, 2, and 3 (indicated by "x"). These settings are repeated for all of them.

### Winding 'x'

#### Paper moisture content of winding 'x'

Water content in the insulating paper of winding 'x' as a % of dry mass. The moisture content of the paper can be determined based on oil samples according to NBR 5356:2017.

**Adjustment range:** 0.0 to 10.0%.

**Default value:** 0.0%.

#### Maximum moisture of winding 'x'

Maximum moisture content in the insulating paper of winding 'x' for normal (non-accelerated) thermal aging. The NBR 5356:2017 standard can be used as a reference, which establishes limits of 2.0% for transformers below 230 kV and 1.5% for transformers of 230 kV and above.

**Adjustment range:** 0.0 to 3.0%.

**Default value:** 1.5%.

#### Initial life of winding 'x'

Initial value of the insulation life of winding 'x'. Should be set to 100% in new transformers.

**Adjustment range:** 0.0 to 100.0%.

**Default value:** 100.0%.

### 5.4.3.6.2. Alarms

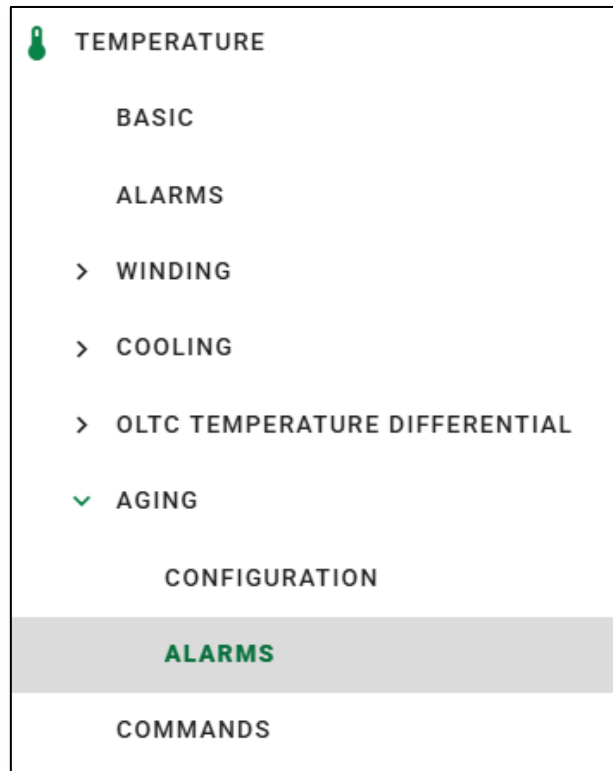

Figure 73 - Aging → Alarms

#### Alarm due to low useful life

The SDV constantly calculates the wear of the winding insulation. When the lifespan falls below the threshold set here, an alarm is issued.

**Adjustment range:** 0.0 to 99.9%.

**Default value:** 10.0%.

#### Alarm due to low lifetime

Based on the load and wear history, SDV calculates the remaining lifespan of the transformer. If the projected remaining lifespan is less than the value set here, an alarm is triggered.

**Adjustment range:** 0.0 to 39.9 years.

**Default value:** 1.0 years.

#### Alarm due to high loss of life

If the calculated life loss rate exceeds the daily limit set here, the alarm will be activated.

**Adjustment range:** 0.000 to 9.999%.

**Default value:** 0.007%.

### 5.4.3.7. Commands

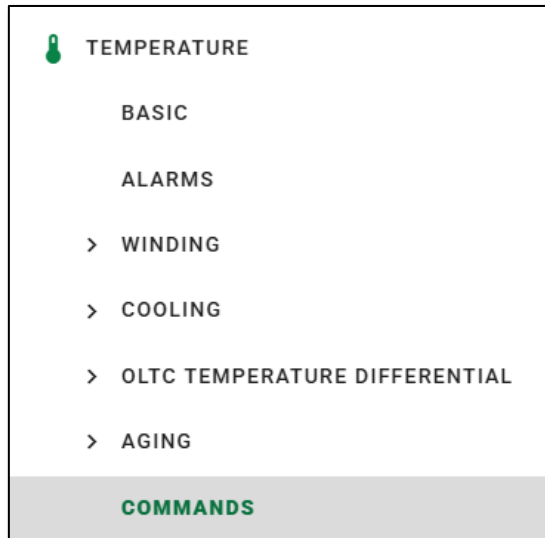

Figure 74 - Cooling → Commands

#### Reset maximum oil temperature

Resets the maximum oil temperature. As a result, the query screen will show the current oil temperature as the maximum until further measurements are taken.

**Adjustment range:** No command, perform reset.

**Default value:** No command.



The following parameters contain settings for RTD and windings 1, 2, and 3 (indicated by "x"). These settings are repeated for all of them.

#### Reset RTD 'x' maximum temperature

Resets the maximum temperature measured by PT100'x'. As a result, the query screen will show the maximum temperature measured by the Pt100 sensor until new measurements occur.

**Adjustment range:** No command, perform reset.

**Default value:** No command.

#### Reset temperature jump - RTD'x'

Resets the PT100'x' jump temperature. As a result, the query screen will show the current temperature measured by the Pt100 sensor until new measurements occur.

**Adjustment range:** No command, perform reset.

**Default value:** No command.

### Reset maximum temperature of winding 'x'

Resets the maximum temperature of winding 'x'. As a result, the query screen will show the current temperature of winding 'x' as the maximum until new measurements are taken.

**Adjustment range:** No command, perform reset.

**Default value:** No command.

## 5.4.4. Regulation

This tab will only be displayed if the “Enable regulation functionality” parameter, located in item [5.4.1.1](#), is set to “YES”.

### 5.4.4.1. Basic

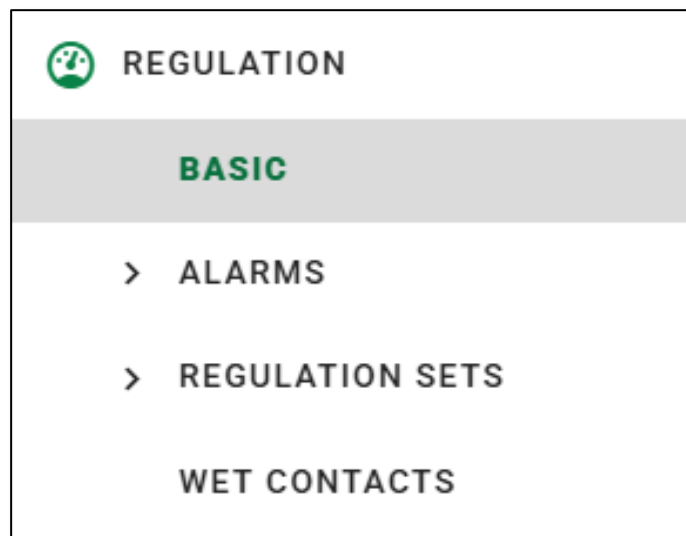

Figure 75 - Regulation → Basic

### Enable tap reading

Choose whether or not to enable the tap reading function.

**Adjustment range:** YES, NO.

**Default value:** YES.

### Regulation mode configuration

This parameter allows the user to select the OLTC regulation mode between "Manual" and "Automatic." When choosing automatic mode, the tap raise and lower commands will be executed automatically, according to the criteria defined by the equipment's algorithms.

Otherwise they will come from manual commands.

**Adjustment range:** Automatic, manual.

**Default value:** Automatic.

### Command mode configuration

This parameter allows the user to select the OLTC command mode between “Local” or “Remote”. When choosing local mode, the command source for the OLTC will be the device itself.

Otherwise the commands will come from an external source, such as another device connected to the network or signals on an input contact.

**Adjustment range:** Remote, local.

**Default value:** Remote.

### Regulation command pulse time

This parameter defines the time to raise and lower the voltage of the control relays, relays 15 and 16, respectively, will be closed.

**Adjustment range:** 0.5 to 2.0 seconds.

**Default value:** 1.0 seconds.

### CT number used for regulation

Select the CT number used for regulation to be parameterized.

**Adjustment range:** 1 to 3.

**Default value:** 1.

### Enable OLTC checking

Activates the relay when the algorithm identifies a tap changer actuation failure.

**Adjustment range:** YES, NO.

**Default value:** NO.

### Enable OLTC maintenance

Choose whether or not to enable the OLTC maintenance function.

**Adjustment range:** YES, NO.

**Default value:** YES.

## 5.4.4.2. Alarms

### 5.4.4.2.1. Parameters

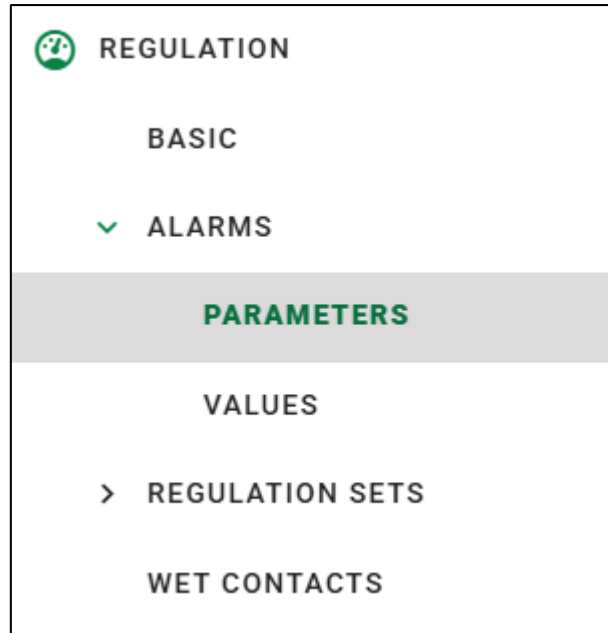

Figure 76 - Alarms → Parameters

#### OLTC block by I>

Activates the relay when there is an alarm due to overcurrent.

**Adjustment range:** YES, NO.

**Default value:** YES.

#### OLTC block by U>

Activates the relay when there is an alarm due to overvoltage.

**Adjustment range:** YES, NO.

**Default value:** YES.

#### OLTC block by U<

Activates the relay when there is an alarm due to undervoltage.

**Adjustment range:** YES, NO.

**Default value:** YES.

#### OLTC block by TAP

Blocking due to tripped tap changer, a situation in which the OLTC keeps changing the tap without having been commanded by a known source, which may mean, among other things, a problem in the mechanism.

**Note:** This parameter will only be displayed if the “Enable tap reading” parameter, located in

item [5.4.4.1](#), is set to “YES”.

**Adjustment range:** YES, NO.

**Default value:** NO.

### OLTC block by RPF

Activates the relay when a reverse power flow (RPF) blocking condition exists.

**Adjustment range:** YES, NO.

**Default value:** YES.

### 5.4.4.2.2. Values

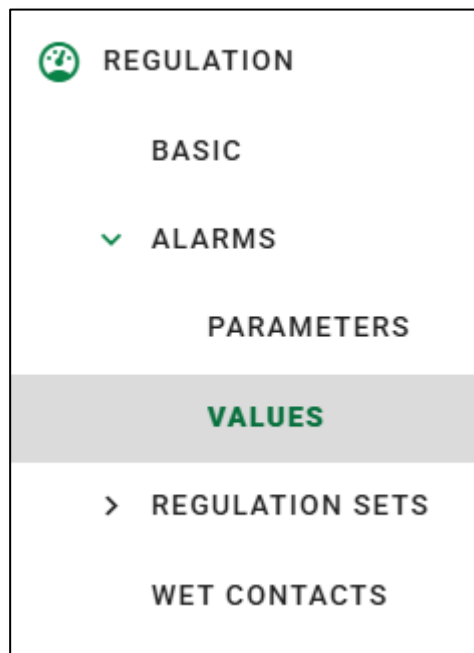

Figure 77 - Alarms → Values

### Alarm due to high voltage on the potentiometric transmitter cursor

If applicable, select the voltage value on the potentiometric transmitter cursor.

**Adjustment range:** 6.0 to 15.0 V.

**Default value:** 10.0 V.

### Alarm due to undervoltage

The alarm due to undervoltage signals an excessive drop in the voltage measured at the VT. This drop can be caused, for example, by a short circuit.

This alarm is issued when the voltage measured in the PT secondary presents a value less than or equal to that set in the U< Alarm parameter, expressed as a percentage of the set nominal voltage.



To avoid false alarms during transformer de-energization, this alarm will not be issued if the measured voltage is below 10% of the nominal voltage. To prevent the SDV from activating the on-load tap changer to try to increase the voltage during a short circuit, the user can select the U< alarm as the condition for tap changer blocking in the OLTC Block parameter.

**Adjustment range:** 10 to 99 %.

**Default value:** 80%.

### Timing for the alarm due to undervoltage

Allows you to set a time delay for the undervoltage alarm, which will only be triggered if the voltage remains below the level established in the Alarm U< parameter for a period longer than the set time.

This prevents unnecessary alarm triggering due to short-term events such as power system transients. The timing is not applied to the on-load tap changer blocking by undervoltage, if selected, which occurs instantly.

**Adjustment range:** 0 to 200 seconds.

**Default value:** 10 seconds.

### Alarm due to overvoltage

This alarm is issued when the voltage measured at the secondary of the PT presents a value greater than or equal to that set in the Alarm U> parameter, expressed as a percentage of the set nominal voltage. This condition can be harmful to the loads connected to the transformer.

When overvoltage occurs, the SDV can immediately operate the on-load tap changer to lower the voltage, disregarding timing settings. If this rapid operation is undesired, the user can select the U> alarm as the condition for tap changer blocking in the OLTC Block parameter.

**Adjustment range:** 101 to 199%.

**Default value:** 120%.

### Timing for the alarm due to overvoltage

Allows you to set a time delay for the overvoltage alarm, which will only be triggered if the voltage remains above the level established in the Alarm U> parameter for a longer time than the set time.

This prevents unnecessary alarm activation due to short-term events such as power system transients. The timing does not apply to on-load tap changer blocking due to overvoltage, if selected, or to rapid voltage reduction operations, which occur instantaneously.

**Adjustment range:** 0 to 200 seconds.

**Default value:** 10 seconds.

### Alarm due to overcurrent

The overcurrent alarm is issued when, due to a short circuit or overload, the line current exceeds the safety margin.

The value to be programmed in this parameter is the line current growth limit, expressed as a percentage of the SDV's nominal current (5A). To calculate the value to be programmed, use the formula below:

$$\text{Parameter} = \frac{\text{lim. } I_{N\text{sec}}}{5} = \frac{\text{lim. } I_N}{5N}$$

Where,

**lim:** percentage limit of current growth relative to nominal line current.

**I<sub>Nsec</sub>:** Nominal current in the secondary of the measuring CT.

**I<sub>N</sub>:** Nominal line current.

**N:** CT current transformation ratio.

**5:** The 5.00 A nominal current value of the SDV.

As an example, consider a situation where the nominal line current is **100 A** and the CT transformation ratio is **40**. If the responsible engineer defines that there will be an overcurrent when the measured current is greater than **150%** of the nominal value, the **I> Alarm** parameter must be programmed with:

$$I_{N\text{sec}} = \frac{I_N}{N} = \frac{100}{40} = 2,5 \text{ A}$$

$$\text{Parameter} = \frac{\text{lim. } I_{N\text{sec}}}{5} = \frac{150 \cdot 2,5}{5} = 75\%$$

Operating the on-load tap changer at high currents can be damaging to its contacts. To prevent the SDV from operating the tap changer to increase voltage during a short circuit, the user can select the **I>** alarm as the condition for tap changer blocking in the OLTC Block parameter.

**Adjustment range:** 10 to 200%.

**Default value:** 200%.

### Timing for the alarm due to overcurrent

Allows you to set a time delay for the overcurrent alarm, which will only be activated if the current remains above the level established in the Alarm **I>** parameter for a longer time than the set time.

This prevents unnecessary alarm activation due to short-term events such as power system transients. The timing does not apply to the load tap changer blocking due to overcurrent, if selected, or to the rapid current reduction operation, which occurs instantaneously.

**Adjustment range:** 0 to 200 seconds.

**Default value:** 10 seconds.

### 5.4.4.3. Regulation sets

#### 5.4.4.3.1. Configuration

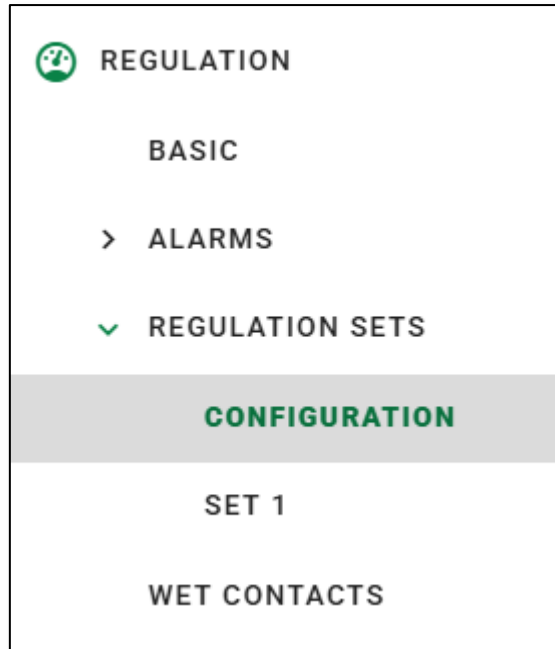

Figure 78 - Regulation sets → Configuration



The following parameters contain settings for regulation sets 2 through 10 (indicated by “x”). These settings are repeated for all of them.

#### Enable regulation - Set ‘x’

The parameterization of set 1 is mandatory, used by default when there is no other active regulation set, while the parameterization of sets 2 to 10 is optional. For this reason, this parameter is not available for set 1.

**Adjustment range:** YES, NO.

**Default value:** NO.

#### 5.4.4.3.2. Set ‘x’



The following parameters contain settings for regulation sets 1 to 10 (indicated by “x”). In order for sets 2 to 10 to be displayed, the “[Enable regulation set ‘x’](#)” parameter must be enabled. These settings are repeated for all of them.

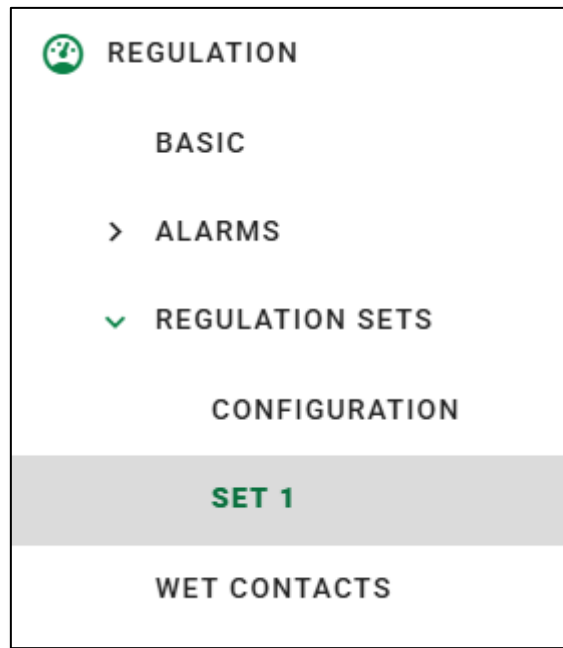

Figure 79 - Regulation sets

### Timing type - Set 'x'

The timing feature is used to prevent unnecessary on-load tap changer operations during momentary line voltage fluctuations, such as may occur during the starting of a large motor.

In this parameter we can select between two types of timing:

- **LINEAR:** where the time to start an on-load tap changer operation (after detecting a voltage deviation greater than the insensitivity) is always equal to the values set in the “Timing Step” parameter, obeying the selected deviation ranges;
- **REVERSE:** where the time to initiate on-load tap-changer operation varies inversely proportional to the deviation of the measured voltage from the nominal voltage (the greater the difference between the measured voltage and the nominal voltage, the shorter the time for on-load tap-changer operation). It is used for faster voltage regulation in case of large voltage deviations.

The timing effectively applied by the SDV after detecting a voltage deviation greater than the insensitivity will be given by:

$$\text{Effective time} = \text{Adjusted time} \cdot \left( \frac{\text{Adjusted deviation}}{\text{Measured deviation}} \right)$$

Where,

- Adjusted time: will be the value programmed in the “Time to Raise” parameter if the measured deviation is negative, or will be the adjustment in “Time to Lower” if the measured deviation is positive, both in “Step ‘x’”;

- Adjusted deviation: is the value programmed in the “Deviation” parameter in “Step ‘x’”.

**Adjustment range:** Linear, Reverse.

**Default value:** Linear.

### Nominal voltage - Set ‘x’

It is the theoretical voltage value that you want to maintain in the load, referring to the secondary of the measuring PT, that is:

$$\text{Nominal voltage} = \frac{\text{Desired voltage at the load}}{\text{PT ratio}}$$

Example:

$$\text{Desired voltage at the load} = 13200 \text{ V}$$

$$\text{PT ratio} = \frac{13800 \text{ V}}{115 \text{ V}} = 120$$

$$\text{Nominal voltage} = \frac{13200 \text{ V}}{120} = 110 \text{ V}$$

**Adjustment range:** 10.0 to 175.0 V.

**Default value:** 115.0 V.

### Subsequent time - Set ‘x’

The time for the first on-load tap-changer operation will be set in the "Timing Step" parameter. If a single tap-changer operation is not enough for the voltage to return to the set limits, the SDV will use the subsequent time setting as the interval for further commands to the on-load tap-changer.

**Adjustment range:** 2 to 180 seconds.

**Default value:** 10 seconds.

## COMPENSATION

### Compensation type - Set ‘x’

Line drop compensation is an SDV feature that allows the load voltage (not the transformer output voltage) to be maintained within set limits, taking into account the line voltage drop between the transformer and the load due to line resistance and reactance. The SDV calculates the load voltage using the transformer output voltage and load current

measurements, in addition to the programmed line parameters. Two user-programmable line drop compensation methods are available in the SDV:

- **RX:** Typically used in systems where line voltage drops are more significant, requiring greater compensation accuracy. Knowledge of two line parameters is required: its Resistance (R) and Reactance (X). When the RX method is selected, the parameters "UR Compensation - Set 'x'" and "UX Compensation - Set 'x'" must be programmed (see below);
- **Z:** This is a simplified method in which a percentage of overall voltage drop is programmed across the line instead of the individual R and X parameters. It does not offer the same accuracy as the RX method because it does not take into account possible variations in the load power factor, which can cause changes in the voltage drop percentage. However, in applications where the load power factor does not undergo significant changes, or if the voltage drop is small, this method can produce satisfactory results, with the advantage of simple adjustments. When the Z method is selected, the "Z Compensation - Set 'x'" parameter must be programmed (see below).

**Adjustment range:** RX, Z.

**Default value:** RX.

#### UR compensation - Set 'x'

This item will only be displayed if the "Compensation Type - Set 'x'" parameter is set to "RX".

It is the resistive component of the voltage drop in the line, in volts, referred to the secondary of the PT and adjusted to the nominal current of the SDV (5 A).

$$U_r = 5 \cdot R \cdot \left( \frac{\text{CT ratio}}{\text{PT ratio}} \right)$$

Where R is the line resistance from the transformer to the load in ohms.

**Adjustment range:** -25.0 to 25.0V.

**Default value:** 10.0 V.

#### UX compensation - Set 'x'

This item will only be displayed if the "Compensation Type - Set 'x'" parameter is set to "RX".

It is the reactive component of the voltage drop in the line, in volts, referred to the secondary of the PT and adjusted to the nominal current of the SDV (5 A).

$$U_x = 5 \cdot X \cdot \left( \frac{\text{CT ratio}}{\text{PT ratio}} \right)$$

Where X is the line reactance between the transformer and the load in ohms.

**Adjustment range:** -25.0 to 25.0V.

**Default value:** 10.0V.

### Z compensation - Set 'x'

This item will only be displayed if the "Compensation Type - Set 'x'" parameter is set to "Z".

It is the line voltage drop as a percentage of the transformer output voltage, adjusted to the SDV nominal current (5A). The Z compensation adjustment can be obtained experimentally by measuring the transformer output voltage, load voltage, and load current simultaneously, then applying the formula below:

$$Z \text{ comp.} = 100 \cdot \left( \frac{\text{Transformer voltage} - \text{Load voltage}}{\text{Transformer voltage}} \right) \cdot \left( \frac{5 \cdot \text{CT ratio}}{\text{Load current}} \right)$$

**Adjustment range:** 0.0 to 15.0%.

**Default value:** 0.0%.

### Compensation limit - Set 'x'

During line drop compensation operation, the SDV will cause a voltage rise at the transformer output to maintain load voltage within limits. This voltage rise will be proportional to the load current, so very high load currents could cause a large voltage rise at the transformer output. To prevent this from occurring, this parameter is programmed to establish an upper voltage rise threshold expressed as a percentage of the nominal voltage.

**Adjustment range:** 0.0 to 25.0%.

**Default value:** 10.0%.



The following parameters contain settings for timing steps 1, 2, and 3 (indicated by "x"). And for regulation sets 1 to 10 (indicated by "y"). These settings are repeated for all of them.

### STEP 'x'

#### Deviation between the voltage measured at the load and the nominal voltage - Step 'x' - Set 'y'

Percentage of deviation between the voltage measured at the load and the nominal (programmed) voltage that, if exceeded, starts counting the times to increase or decrease the voltage, programmed as described below..

**Adjustment range:** 0.1 to 9.8%.

**Default value:** 2.5%.

#### Timing for the first OLTC voltage increase command - Step 'x' - Set 'y'

Timing for the first voltage increase command to the on-load tap changer. (according to the "[Timing type - Set 'x'](#)" parameter).

**Adjustment range:** 0 to 180 seconds.

**Default value:** 15 seconds.

### Timing for the first OLTC voltage decrease command - Step 'x' - Set 'y'

Timing for the first voltage drop command to the on-load tap-changer (according to the "[Timing type - Set 'x'](#)" parameter).

**Adjustment range:** 0 to 180 seconds.

**Default value:** 15 seconds.



The following parameters contain unique settings for regulation sets 2 through 10 (indicated by "x").  
These settings are repeated for all of them.

## TIME SLOT

### Time slot for set activation - Start day - Set 'x'

Energy demand variation, the default is set 1, the regulation system works according to the settings of set 1. From the days, hours, minutes configured in the parameterization of set 1, when reaching the configured value, it will start to interpret the value of set 'x' (2 to 10).

**Adjustment range:**

- Dom (Sunday);
- Seg (Monday);
- Ter (Tuesday);
- Qua (Wednesday);
- Qui (Thursday);
- Sex (Friday);
- Sab (Saturday).

**Default value:** Dom (Sunday);

### Time slot for set activation - Start hour - Set 'x'

Indicates the starting hour for the time slot of the set 'x'.

**Adjustment range:** 0 to 23 hours.

**Default value:** 0 hours.

### Time range for set activation - Start minute - Set 'x'

Indicates the starting minutes for the time slot of the set 'x'.

**Adjustment range:** 0 to 59 minutes.

**Default value:** 0 minutes.

#### Time slot for set activation - End day - Set 'x'

Select the ending day of the week for the time slot of the set 'x'.

**Adjustment range:**

- Dom (Sunday);
- Seg (Monday);
- Ter (Tuesday);
- Qua (Wednesday);
- Qui (Thursday);
- Sex (Friday);
- Sab (Saturday).

**Default value:** Dom (Sunday);

#### Time slot for set activation - End hour - Set 'x'

Indicates the end hour for the time slot of the set 'x'.

**Adjustment range:** 0 to 23 hours.

**Default value:** 0 hours.

#### Time range for set activation - End minute - Set 'x'

Indicates final minutes for time slot of set 'x'.

**Adjustment range:** 0 to 59 minutes.

**Default value:** 0 minutes.

#### 5.4.4.4. OLTC position measurement

This tab will only be displayed if the “Enable tap reading” parameter, located in item [5.4.4.1](#), is set to “YES”.

#### 5.4.4.4.1. Configuration

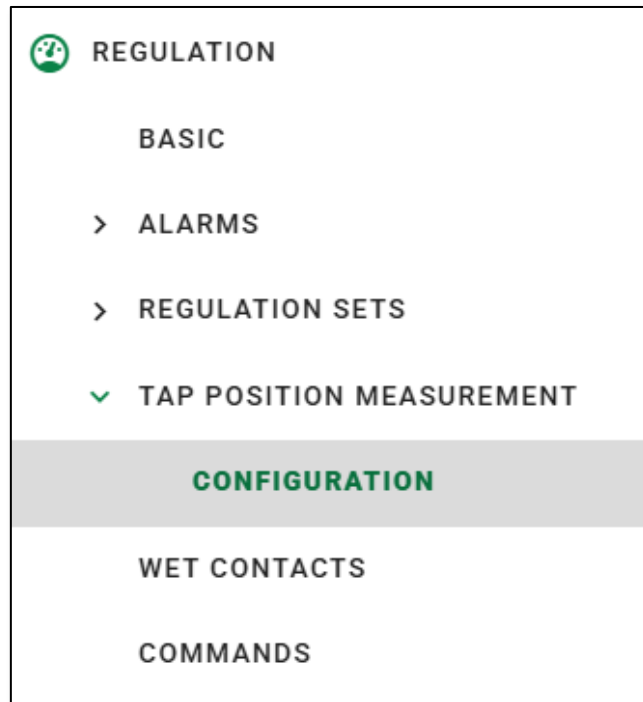

Figure 80 - OLTC position measurement → Configuration



The following parameters are available for all three tap measurement types (Potentiometric Transmitter, BCD, and mA Current Loop). These settings are repeated for all of them..

#### Configuration of tap indication type

There are several methods for measuring tap position. Depending on the model of the OLTC being monitored, choose one of the methods listed below.

##### Adjustment range:

- Bilateral;
- Inverse bilateral;
- Alphanumeric;
- Inverse alphanumeric;
- Simple numeric;

**Default value:** Simple numeric.

#### Configuration of tap changing time

Parameterize the time required for the OLTC to change a tap position.



**Adjustment range:** 1 to 100 seconds.

**Default value:** 10 seconds.

### Central tap

Enter the OLTC central tap here.

**Adjustment range:** 2 to 34.

**Default value:** 17.

### Number of taps the OLTC has

Select the number of OLTC taps that the SDV should monitor.

**Adjustment range:** 1 to 49.

**Default value:** 33.

### Minimum tap

Set the number of the smallest tap to be allowed.

**Adjustment range:** 1 to 49.

**Default value:** 1.

### Maximum tap

Set the number of the largest tap to be allowed.

**Adjustment range:** 1 to 49.

**Default value:** 33.

### Command configuration to define whether raising the tap increases or decreases the voltage

In some OLTC, raising the tap can be an operation that raises or lowers the voltage. This parameter should indicate the type of OLTC used.

**Adjustment range:** Increase voltage, decrease voltage.

**Default value:** Increase voltage.

### Selecting the type of the OLTC position measuring sensor

There are three types of OLTC position measurement, please choose one of the measurement types listed below.

**Adjustment range:**

- Potentiometric transmitter;
- BCD;
- mA current loop.

**Default value:** Potentiometric transmitter.

## POTENTIOMETRIC TRANSMITTER SETTINGS

This parameter will only be displayed if “Selecting the type of the OLTC position measuring sensor” is set to “Potentiometric transmitter”.



Selection of sensor type for tap position measure: Potentiometric crown

Figure 81 - Selection of potentiometric transmitter measurement

### Setting the resistance between potentiometric transmitter steps

Set the resistance value between steps of the potentiometric transmitter used to measure the tap position.

**Adjustment range:** 4.7 to 20.0 Ω.

**Default value:** 10.0 Ω.

### Setting the initial offset of the potentiometric transmitter

Choose the value of the initial step of the resistance of the transmitter, proportional to the “Resistance” parameter, that is, Initial Resistance = Initial Offset \* Resistance.

**Adjustment range:** 0 to 5.

**Default value:** 0.

### Setting the final offset of the potentiometric transmitter

Choose the value of the final step of the resistance of the crown, proportional to the “Resistance” parameter, that is, Final Resistance = Final Offset \* Resistance.

**Adjustment range:** 0 to 5.

**Default value:** 0.



The following parameters contain settings for intermediate OLTC positions, where the user can create rules 1, 2, and 3 (indicated by “x”). These settings are repeated for all of them.

### Enable rule ‘x’ of transition tap positions

Enable or disable intermediate tap parameterization.

**Adjustment range:** YES, NO.

**Default value:** NO.

### Enable resistance on intermediate taps - Rule ‘x’

Indicates whether or not the intermediate taps have step resistance.

**Adjustment range:** YES, NO.

**Default value:** NO.

### Intermediate tap position - Rule 'x'

Enter the starting tap position of the switch that has an intermediate transition, n. The n+1 will be updated automatically and the starting position must be between 1 and 48 (when the number of taps of the switch is 49).

**Adjustment range:** 1 to 48.

**Default value:** 1.

### Number of intermediate taps - Rule 'x'

Enter the number of operations that occur until the transition between the initial and final tap is complete.

**Adjustment range:** 2 to 5.

**Default value:** 2.

### Potentiometric transmitter measurement method

Select the tap position measurement method from normal, simple calibration, or advanced calibration. If the selected measurement method is simple or advanced calibration, the transmitter calibration parameters will be activated in the "Calibration" menu.

**Adjustment range:**

- Normal;
- Simple calibration;
- Advanced calibration;

**Default value:** Normal.

### mA SENSOR SETTINGS

This parameter will only be displayed if "Selecting the type of the OLTC position measuring sensor" is set to "mA Current Loop".



✓ Selection of sensor type for tap position measure: mA current loop

Figure 82 - mA current loop measurement selection

## Current scale of the mA tap sensor

Parameter for mA tap sensor current scale.

### Adjustment range:

- 0..5 mA;
- 0..10 mA;
- 0..20 mA;
- 4..20 mA;

**Default value:** 0..20 mA;

### 5.4.4.4.2. Calibration

This tab will only be displayed when the “Selecting the type of the OLTC position measuring sensor” parameter is set to “Potentiometric Crown” and the “Potentiometric transmitter measurement method” parameter is set to “Simple ” or “Advanced” Both parameters are located in item [5.4.4.4.1](#).

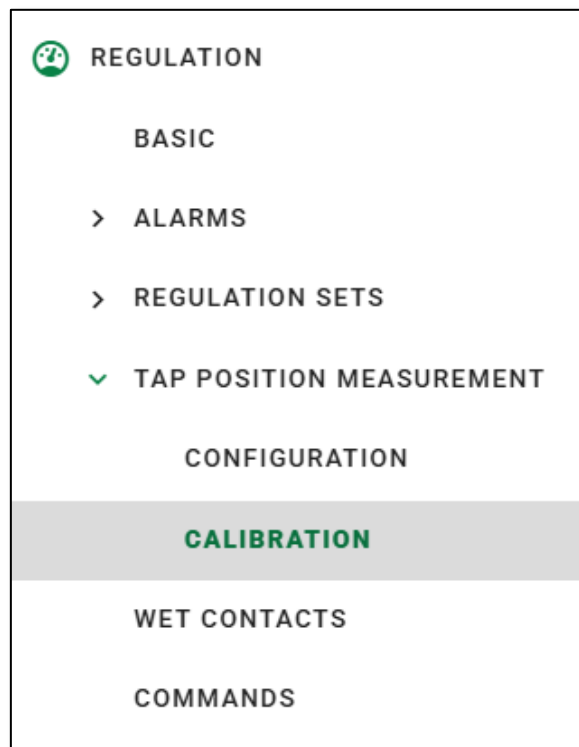

Figure 83 - OLTC position measurement → Calibration

### Tap position at calibration

Indicates the current tap position for calibration. This parameter will only be displayed if the "Potentiometric transmitter measurement method" parameter is set to "Simple Cal." or "Advanced Cal.".

**Adjustment range:** 1 to 49.

**Default value:** 1.

#### Transmitter temperature at time of calibration

Potentiometric transmitter temperature at the time of calibration. This parameter will only be displayed if the “Potentiometric transmitter measurement method” parameter is set to “Advanced Cal.”.

**Adjustment range:** -55 to 200°C.

**Default value:** 25°C.

#### Temperature of the transmitter connection wires at the time of calibration

Temperature of the potentiometric transmitter connection wires in the SDV at the time of calibration. This parameter will only be displayed if the “Potentiometric transmitter measurement method” parameter is set to “Advanced Cal.”.

**Adjustment range:** -55 to 200°C.

**Default value:** 25°C.

#### Potentiometric transmitter calibration - Short circuit in the lower part

After shorting the measurement inputs of the cursor and the start of the potentiometric transmitter (SDV terminals 35 and 37), select the "Calibrate" option to have the SDV perform the calibration. This parameter will only be displayed if the “Potentiometric transmitter measurement method” parameter is set to “Advanced Cal.”.

**Adjustment range:** No command, Calibrate.

**Default value:** No command.

#### Potentiometric transmitter calibration - Short circuit in the upper part

After shorting the measurement inputs of the cursor and the end of the potentiometric transmitter (SDV terminals 36 and 37), select "Calibrate" for the SDV to perform the calibration. This parameter will only be displayed if the “Potentiometric transmitter measurement method” parameter is set to “Advanced Cal.”.

**Adjustment range:** No command, Calibrate.

**Default value:** No command.

#### 5.4.4.5. OLTC check

This tab will only be displayed if the “Enable OLTC checking” parameter, located in item [5.4.4.1](#), is set to “YES”.

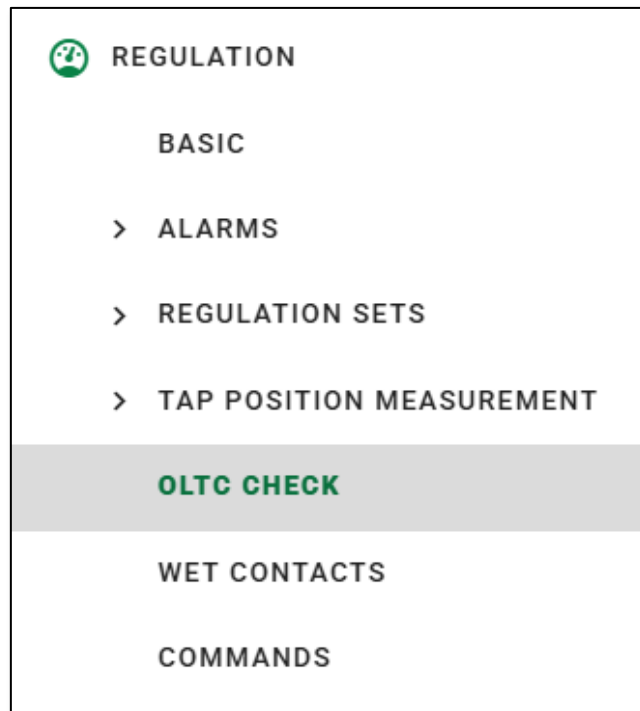

Figure 84 - Regulation → OLTC check

#### Limit of attempts to generate a regulation failure alarm on the tap changer

Select the number of times the SDV should check the OLTC before generating an alarm.

**Adjustment range:** 1 to 99.

**Default value:** 5.

#### 5.4.4.6. OLTC maintenance

This tab will only be displayed if the “Enable OLTC maintenance” parameter, located in item [5.4.4.1](#), is set to “YES”.

#### 5.4.4.6.1. Initial configuration

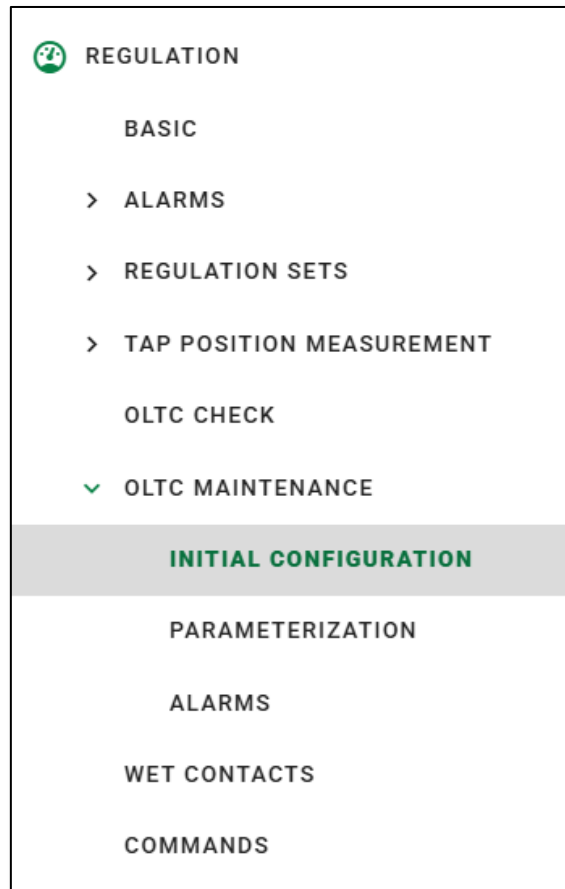

Figure 85 - OLTC maintenance → Initial configuration

#### OLTC maintenance notice acknowledgment

Allows the HMI to block the display of warnings that are active at the time of the command. The blocking is automatically disabled only when both warnings are also disabled.

**Adjustment range:** No command, Acknowledge warning.

**Default value:** Acknowledge warning.

#### Perform OLTC maintenance

The perform OLTC maintenance command clears maintenance alarms and warnings, resets the counters for the number of operations after maintenance and the switched current per square unit after maintenance.

**Adjustment range:** No command, Perform maintenance.

**Default value:** Perform maintenance.

#### Reset OLTC measurements

Resets the average number of OLTC operations and the switched current.

**Adjustment range:** No command, Perform reset  
**Default value:** No command.

### Enable the accounting of intermediate TAPs as number of operations

Enables or disables the intermediate tap parameterization.

**Adjustment range:** YES, NO.  
**Default value:** NO.

#### 5.4.4.6.2. Parameterization

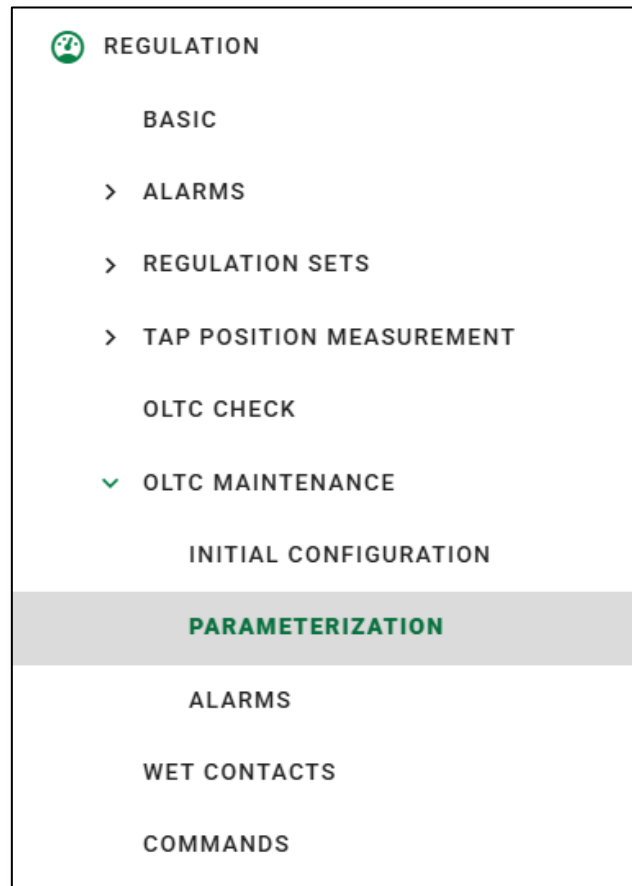

Figure 86 - OLTC maintenance → Parameterization



The following parameters contain settings for the multiplier factor for calculating the sum of squared switched current – rules 1, 2, and 3 (indicated by "x"). These settings are repeated for all of them.

### Multiplying factor for calculating the sum of squared switched current - Rule 'x'

Definition of the multiplying factor of the integral of the square of the switched current ( $I^2$ ).



**Adjustment range:** 1 to 5.

**Default value:** 1.

### Configuration of days for calculating the average number of tap changes

Defines the number of days that will be used for calculating both the average daily tap changes and the average daily switched current squared  $I_{pu}^2$ .

**Adjustment range:** 10 to 365 days.

**Default value:** 10 days.

### OLTC nominal current

Sets the nominal on-load tap changer current referred to the secondary of the measuring CT. The setting is used as the basis for converting the measured load current during tap changing from amperes to p.u. (per unit).

**Adjustment range:** 0.10 to 10.00 A.

**Default value:** 5.00 A.

### OLTC total number of operations

Sets the total number of tap operations since the OLTC began operating. Allows you to adjust the ongoing number of tap operations so that the SDV count matches the mechanical counter found in most OLTCs.

The OLTC operation counter is incremented each time the measured tap position changes.

**Adjustment range:** 0 to 999999.

**Default value:** 0.

### OLTC number of operations since last maintenance

Sets the partial number of OLTC operations since the last maintenance or inspection performed on the OLTC. Allows you to adjust the number of operations since maintenance on tap changers that were already in operation when the SDV was installed.

The counter is incremented each time the measured tap position changes.

**Adjustment range:** 0 to 999999.

**Default value:** 0.

### Adjusting the limit for the sum of the switched current squared by the OLTC

Defines the sum of the current switched by the OLTC squared ( $I_{pu}^2$ ) since the beginning of its operation and allows you to adjust the ongoing value of this sum in tap changers that were already in operation when the SDV was installed.

The sum is incremented by the measured load current value, converted to p.u. (per unit) and squared, at the instant a change in the OLTC tap position occurs.

**Adjustment range:** 0.000 to 2000.000 Ipu<sup>2</sup>.10<sup>3</sup>.

**Default value:** 0.000 Ipu<sup>2</sup>.10<sup>3</sup>.

### Adjusting the limit for the sum of the switched current squared by the OLTC after maintenance

Defines the sum of the current switched by the OLTC squared (Ipu<sup>2</sup>) since the last maintenance carried out on the OLTC. It allows you to adjust the ongoing value of this sum in tap changers that were already in operation when the SDV was installed.

The sum is incremented by the measured load current value, converted to p.u. (per unit) and squared, at the instant a change in the OLTC tap position occurs.

**Adjustment range:** 0.000 to 2000.000 Ipu<sup>2</sup>.10<sup>3</sup>.

**Default value:** 0.000 Ipu<sup>2</sup>.10<sup>3</sup>.

#### 5.4.4.6.3. Alarms

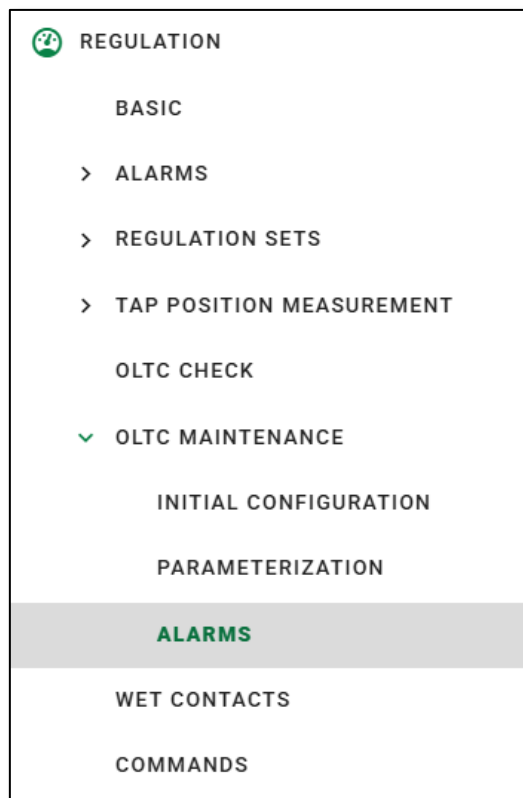

Figure 87 - OLTC maintenance → Alarms

### Number of days in advance for issuing the maintenance warning

Sets the number of days in advance that the tap changer maintenance notice will be issued.

**Adjustment range:** 0 to 365 days.

**Default value:** 30 days.



### Alarm due to number of OLTC operations

Sets the number of operations required for OLTC maintenance, as specified by the manufacturer. When the "Total number of OLTC operations after maintenance" counter reaches the configured value, the SDV issues a warning indicating that maintenance on the tap changer must be performed. The warning can be signaled by a programmable output relay.

The maintenance warning indication remains active on the SDV, and the programmed warning contacts will remain activated until the user manually acknowledges the warnings. This procedure informs the SDV that maintenance has been performed. Once this acknowledgement is made, the "Total number of OLTC operations after maintenance" register is reset, and maintenance warnings are deactivated.

**Adjustment range:** 0 to 999999.

**Default value:** 150000.

### Adjusting the limit for the sum of the switched current squared by the OLTC for maintenance warning

Sets the value of the sum of the current switched by the OLTC squared ( $I_{pu2}$ ) for OLTC maintenance, as indicated by its manufacturer. When the "Adjustment of the sum of the OLTC  $I_{pu}^2$  after maintenance" counter reaches the configured value, the SDV issues a warning indicating that maintenance on the tap changer must be performed.

The maintenance warning indication remains active on the SDV, and the programmed warning contacts will remain activated until the user manually acknowledges the warnings. This procedure informs the SDV that maintenance has been performed. Once this acknowledgement is performed, the "Adjustment of the sum of the OLTC  $I_{pu}^2$  after maintenance" register is reset, and maintenance warnings are deactivated.

**Adjustment range:** 0.000 to 2000.000  $I_{pu}^2 \cdot 10^3$ .

**Default value:** 2000.000  $I_{pu}^2 \cdot 10^3$ .

#### 5.4.4.7. Wet contacts

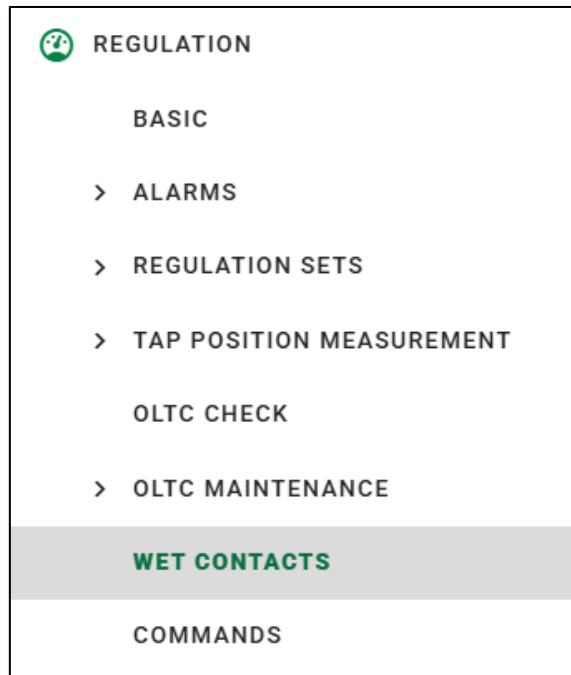

Figure 88 - Wet contacts



The following parameters contain settings for wet contact 1 to 6 (indicated by “x”). These settings are repeated for all of them.

#### Configuration of wet contact ‘x’

The SDV can receive various types of commands from external sources, such as control panels and buttons installed in locations remote from the device. When entering this parameter, select the contact you want to configure and determine its function:

##### Adjustment range:

- -;
- **Local/Remoto:** Allows you to remotely define whether the device should receive commands locally or from a remote source (level 0 = local / level 1 = remote).
- **Autom./Manual:** Configures the selected input contact to receive a signal indicating whether the device should provide automatic or manual voltage regulation (level 0 = automatic / level 1 = manual).
- **Increase TAP:** Configures the selected input contact to receive a remote command pulse to raise the tap.
- **Decrease TAP:** Configures the selected input contact to receive a remote command pulse to lower the tap.

- **Block OLTC:** Activates the OLTC blocking alarm, activating relays. Blocks automatic tap change commands but allows manual commands.
- **Enable parallelism concentrator:** Configures the selected input contact to remotely enable or disable the parallelism concentrator function (level 0 = disabled / level 1 = enabled).

**Default value:** -.

### Digital input reading mode

Select the desired reading mode.

### Adjustment range:

- **LATCH:** parameters follow the state of the contact (0 when open, 1 when closed);
- **PULSE:** the regulation parameters are toggled on the rising edge of the signal (contact closure). For a pulse to be accepted, all conditions for executing its respective command must be met **at the time of its transmission**. If this is not the case, the pulses are ignored.

**Default value:** LATCH.

### 5.4.4.8. Commands

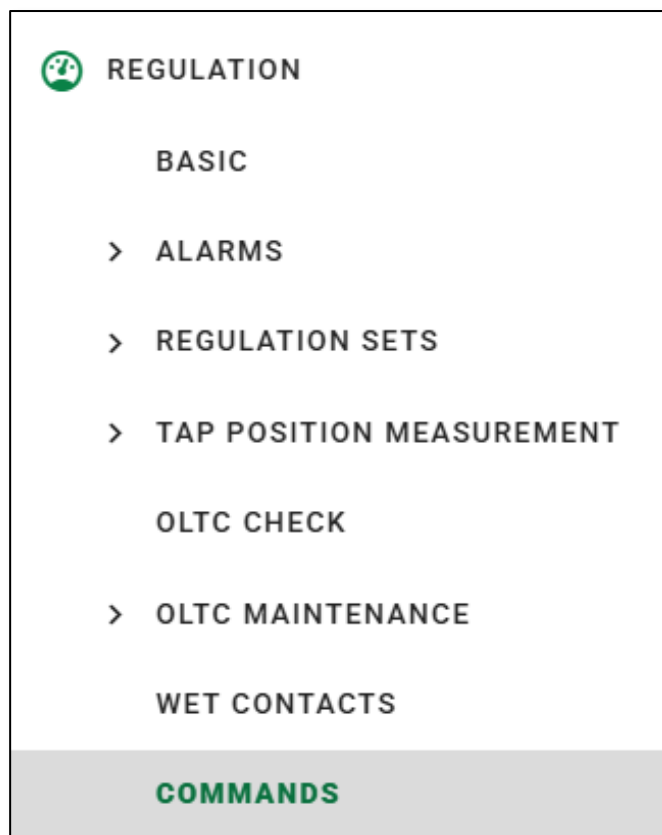

Figure 89 - Commands



### Minimum tap reset

Resets historical minimum tap values. Consequently, the query screen will display the ongoing tap value as the minimum tap until further changes occur.

**Adjustment range:** No command, Perform reset.

**Default value:** No command.

### Maximum tap reset

Resets historical maximum tap values. Consequently, the query screen will display the ongoing tap value as the maximum tap until further changes occur.

**Adjustment range:** No command, Perform reset.

**Default value:** No command.

### Decrease tap

Select the tap down command. This command will only be possible if the SDV is configured in local and manual mode.

**Adjustment range:** No command, Decrease tap.

**Default value:** No command.

### Increase tap

Selects the tap up command. This command will only be possible if the SDV is configured in local and manual mode.

**Adjustment range:** No command, Increase tap.

**Default value:** No command.

### Clear OLTC trigger blocking

Command to reset the OLTC blocking due to OLTC triggered.

**Adjustment range:** No command, Perform reset.

**Default value:** No command.

## 5.4.5. Relays

### 5.4.5.1. General

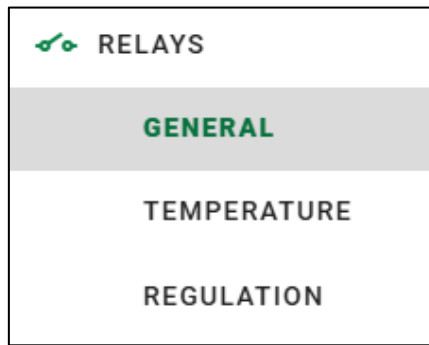

Figure 90 - Relays → General

Relay	Operating mode
1	<input type="radio"/> NORMAL <input type="radio"/> INVERTED
2	<input type="radio"/> NORMAL <input type="radio"/> INVERTED
3	<input type="radio"/> NORMAL <input type="radio"/> INVERTED
4	<input type="radio"/> NORMAL <input type="radio"/> INVERTED
5	<input type="radio"/> NORMAL <input type="radio"/> INVERTED

Figure 91 - Activation by the general equipment status

### General configuration of relays 1 to 5.

#### Operating mode

Defines the operating mode of relays 1 through 5, which are fixed as NO (normally open) due to the hardware definition. However, SDV allows the wiring logic to be inverted by the firmware, so that all relays can operate in both NO and NC modes.

**Adjustment range:** Normal, inverted.

**Default value:** Normal.

### 5.4.5.2. Temperature

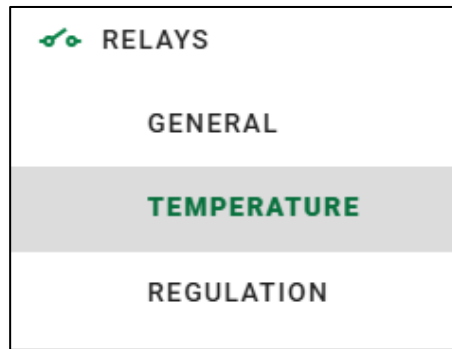

Figure 92 - Relays → Temperature

Table of configuration of relays for oil and windings

Relay	Activation							
	Oil alarm	Oil shutdown timing	Alarm of winding 1	Winding 1 shutdown timing	Alarm of winding 2	Winding 2 shutdown timing	Alarm of winding 3	Winding 3 shutdown timing
1	<input type="checkbox"/>	<input type="checkbox"/>	<input type="checkbox"/>	<input type="checkbox"/>	<input type="checkbox"/>	<input type="checkbox"/>	<input type="checkbox"/>	<input type="checkbox"/>
2	<input type="checkbox"/>	<input type="checkbox"/>	<input type="checkbox"/>	<input type="checkbox"/>	<input type="checkbox"/>	<input type="checkbox"/>	<input type="checkbox"/>	<input type="checkbox"/>
3	<input type="checkbox"/>	<input type="checkbox"/>	<input type="checkbox"/>	<input type="checkbox"/>	<input type="checkbox"/>	<input type="checkbox"/>	<input type="checkbox"/>	<input type="checkbox"/>
4	<input type="checkbox"/>	<input type="checkbox"/>	<input type="checkbox"/>	<input type="checkbox"/>	<input type="checkbox"/>	<input type="checkbox"/>	<input type="checkbox"/>	<input type="checkbox"/>
5	<input type="checkbox"/>	<input type="checkbox"/>	<input type="checkbox"/>	<input type="checkbox"/>	<input type="checkbox"/>	<input type="checkbox"/>	<input type="checkbox"/>	<input type="checkbox"/>

Figure 93 - Table of Configuration of relays for oil and windings

#### Configuration of relays 1 to 5 for oil and windings.

##### Oil alarm

Activates relay when there is an oil temperature alarm.

**Adjustment range:** YES, NO.

**Default value:** NO.

##### Oil shutdown timing

Activates the relay when there is a timing in progress for shutdown due to oil temperature.

**Adjustment range:** YES, NO.

**Default value:** NO.

##### Alarm of Winding 'x' (1, 2 and 3)

Activates relay due to temperature alarm of winding "x" (1, 2 or 3).

**Adjustment range:** YES, NO.

**Default value:** NO.

### Winding 'x' (1, 2 and 3) shutdown timing

Activates the relay when there is a timing in progress for shutdown due to temperature of winding "x".

**Adjustment range:** YES, NO.

**Default value:** NO.

Table of configuration of relays for cooling monitoring

Relay	Group 1			Group 2		
	High current	Low current	Improper Activation	High current	Low current	Improper Activation
1	<input type="checkbox"/>	<input type="checkbox"/>	<input type="checkbox"/>	<input type="checkbox"/>	<input type="checkbox"/>	<input type="checkbox"/>
2	<input type="checkbox"/>	<input type="checkbox"/>	<input type="checkbox"/>	<input type="checkbox"/>	<input type="checkbox"/>	<input type="checkbox"/>
3	<input type="checkbox"/>	<input type="checkbox"/>	<input type="checkbox"/>	<input type="checkbox"/>	<input type="checkbox"/>	<input type="checkbox"/>
4	<input type="checkbox"/>	<input type="checkbox"/>	<input type="checkbox"/>	<input type="checkbox"/>	<input type="checkbox"/>	<input type="checkbox"/>
5	<input type="checkbox"/>	<input type="checkbox"/>	<input type="checkbox"/>	<input type="checkbox"/>	<input type="checkbox"/>	<input type="checkbox"/>

Figure 94 - Table of configuration of relays for cooling monitoring 1-2

Relay	Group 3			Group 4		
	High current	Low current	Improper Activation	High current	Low current	Improper Activation
1	<input type="checkbox"/>	<input type="checkbox"/>	<input type="checkbox"/>	<input type="checkbox"/>	<input type="checkbox"/>	<input type="checkbox"/>
2	<input type="checkbox"/>	<input type="checkbox"/>	<input type="checkbox"/>	<input type="checkbox"/>	<input type="checkbox"/>	<input type="checkbox"/>
3	<input type="checkbox"/>	<input type="checkbox"/>	<input type="checkbox"/>	<input type="checkbox"/>	<input type="checkbox"/>	<input type="checkbox"/>
4	<input type="checkbox"/>	<input type="checkbox"/>	<input type="checkbox"/>	<input type="checkbox"/>	<input type="checkbox"/>	<input type="checkbox"/>
5	<input type="checkbox"/>	<input type="checkbox"/>	<input type="checkbox"/>	<input type="checkbox"/>	<input type="checkbox"/>	<input type="checkbox"/>

Figure 95 - Table of configuration of relays for cooling monitoring 3-4

### Configuration of relays 1 to 5 for cooling monitoring

For the four cooling groups to be displayed in the table, the "Configuration of number of cooling groups" parameter, located in item [5.4.3.4.1](#), must be set to 4. The table will only display the cooling groups according to the quantity specified in this parameter.

### Group 'x' (1, 2, 3 and 4)

#### High current

Activates the relay for an alarm due to high current in cooling group "x" (1, 2, 3 or 4).

**Adjustment range:** YES, NO.

**Default value:** NO.

### Low current

Activates the relay for an alarm due to low current in cooling group “x” (1, 2, 3 or 4).

**Adjustment range:** YES, NO.

**Default value:** NO.

### Improper activation

Activates the relay for an alarm due to improper activation of cooling group “x” (1, 2, 3 or 4).

**Adjustment range:** YES, NO.

**Default value:** NO.

Table of configuration of relays for OLTC temperature differential		
Relay	Activation	
	Instantaneous differential alarm	Filtered differential alarm
1	<input type="checkbox"/>	<input type="checkbox"/>
2	<input type="checkbox"/>	<input type="checkbox"/>
3	<input type="checkbox"/>	<input type="checkbox"/>
4	<input type="checkbox"/>	<input type="checkbox"/>
5	<input type="checkbox"/>	<input type="checkbox"/>

Figure 96 - Table of configuration of relays for OLTC temperature differential

### Configuration of relays 1 to 5 for OLTC temperature differential

This table will only be displayed if the “Enable temperature sensor ‘x’” parameter, located in item [5.4.3.1](#) is set to “YES” and then a PT100 sensor is selected in the “Temperature sensor selection for the tap changer” parameter.

#### Instantaneous differential alarm

Activates relays when there is an alarm due to an instantaneous temperature differential between the transformer and the tap changer.

**Adjustment range:** YES, NO.

**Default value:** NO.

#### Filtered differential alarm

Activates relays when there is an alarm due to a filtered temperature differential between the transformer and the tap changer.

**Adjustment range:** YES, NO.

**Default value: NO.**

Table of configuration of relays for aging

Relay	Winding 1			Winding 2			Winding 3		
	Low useful life	High loss of life	Low lifetime	Low useful life	High loss of life	Low lifetime	Low useful life	High loss of life	Low lifetime
1	<input type="checkbox"/>	<input type="checkbox"/>	<input type="checkbox"/>	<input type="checkbox"/>	<input type="checkbox"/>	<input type="checkbox"/>	<input type="checkbox"/>	<input type="checkbox"/>	<input type="checkbox"/>
2	<input type="checkbox"/>	<input type="checkbox"/>	<input type="checkbox"/>	<input type="checkbox"/>	<input type="checkbox"/>	<input type="checkbox"/>	<input type="checkbox"/>	<input type="checkbox"/>	<input type="checkbox"/>
3	<input type="checkbox"/>	<input type="checkbox"/>	<input type="checkbox"/>	<input type="checkbox"/>	<input type="checkbox"/>	<input type="checkbox"/>	<input type="checkbox"/>	<input type="checkbox"/>	<input type="checkbox"/>
4	<input type="checkbox"/>	<input type="checkbox"/>	<input type="checkbox"/>	<input type="checkbox"/>	<input type="checkbox"/>	<input type="checkbox"/>	<input type="checkbox"/>	<input type="checkbox"/>	<input type="checkbox"/>
5	<input type="checkbox"/>	<input type="checkbox"/>	<input type="checkbox"/>	<input type="checkbox"/>	<input type="checkbox"/>	<input type="checkbox"/>	<input type="checkbox"/>	<input type="checkbox"/>	<input type="checkbox"/>

Figure 97 - Table of configuration of relays for aging

### Configuration of relays 1 to 5 for aging

This table will only be displayed if the “Enable aging” parameter, located in item [5.4.3.1](#), is set to “YES”.

#### Winding ‘x’ (1, 2 and 3)

##### Low useful life

Activates relay when there is an alarm due to low life for winding “x” (1, 2 or 3) insulation.

**Adjustment range:** YES, NO.

**Default value:** NO.

##### High loss of life

Activates relay when there is an alarm due to high loss of life for winding “x” insulation.

**Adjustment range:** YES, NO.

**Default value:** NO.

##### Low lifetime

Activates relay when there is an alarm due to low remaining lifetime for winding “x” (1, 2 or 3) insulation.

**Adjustment range:** YES, NO.

**Default value:** NO.

### 5.4.5.3. Regulation

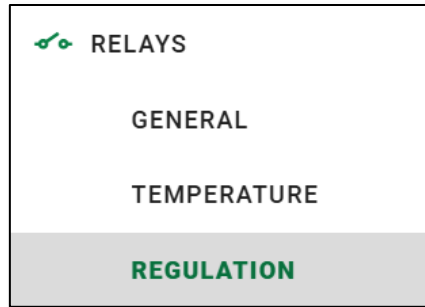

Figure 98 - Relays → Regulation

Table of configuration of relays for general regulation warnings

Relay	Activation			
	TAP reading self-diagnosis	U< alarm	U> alarm	I> alarm
1	<input type="checkbox"/>	<input type="checkbox"/>	<input type="checkbox"/>	<input type="checkbox"/>
2	<input type="checkbox"/>	<input type="checkbox"/>	<input type="checkbox"/>	<input type="checkbox"/>
3	<input type="checkbox"/>	<input type="checkbox"/>	<input type="checkbox"/>	<input type="checkbox"/>
4	<input type="checkbox"/>	<input type="checkbox"/>	<input type="checkbox"/>	<input type="checkbox"/>
5	<input type="checkbox"/>	<input type="checkbox"/>	<input type="checkbox"/>	<input type="checkbox"/>

Figure 99 - Table of configuration of relays for general regulation warnings

#### Configuration of relays 1 to 5 for general regulation warnings

##### TAP reading self-diagnosis

Activates relay when there is tap reading self-diagnosis.

**Note:** If the “Enable tap reading” parameter, located in item [5.4.4.1](#), is set to “NO”, it will not be possible to configure this parameter.

**Adjustment range:** YES, NO.

**Default value:** NO.

##### U< Alarm

Activates relay when there is an undervoltage alarm.

**Adjustment range:** YES, NO.

**Default value:** NO.

##### U> Alarm

Activates relay when there is an overvoltage alarm.

**Adjustment range:** YES, NO.  
**Default value:** NO.

### I> Alarm

Activates relay when there is an overcurrent alarm.

**Adjustment range:** YES, NO.  
**Default value:** NO.

Table of configuration of relays for OLTC check

Relay	Activation	
	OLTC check	
1	<input type="checkbox"/>	
2	<input type="checkbox"/>	
3	<input type="checkbox"/>	
4	<input type="checkbox"/>	
5	<input type="checkbox"/>	

Figure 100 - Table of configuration of relays for OLTC check

### Configuration of relays 1 to 5 for OLTC check

This table will only be displayed if the parameter “Enable OLTC checking”, located in item [5.4.4.1](#), is set to “YES”.

### OLTC check

Activates relay when the algorithm identifies tap changer actuation failure.

**Adjustment range:** YES, NO.  
**Default value:** NO.

Table of configuration of relays for OLTC maintenance

Relay	Activation			
	Perform maintenance by number of operations	Warning for maintenance by number of operations	Perform maintenance by I <sup>2</sup> sum	Warning for maintenance by I <sup>2</sup> sum
1	<input type="checkbox"/>	<input type="checkbox"/>	<input type="checkbox"/>	<input type="checkbox"/>
2	<input type="checkbox"/>	<input type="checkbox"/>	<input type="checkbox"/>	<input type="checkbox"/>
3	<input type="checkbox"/>	<input type="checkbox"/>	<input type="checkbox"/>	<input type="checkbox"/>
4	<input type="checkbox"/>	<input type="checkbox"/>	<input type="checkbox"/>	<input type="checkbox"/>
5	<input type="checkbox"/>	<input type="checkbox"/>	<input type="checkbox"/>	<input type="checkbox"/>

Figure 101 - Table of configuration of relays for OLTC maintenance

## Configuration of relays 1 to 5 for OLTC maintenance

This table will only be displayed if the “Enable OLTC maintenance” parameter, located in item [5.4.4.1](#), is set to “YES”.

### Perform maintenance by number of operations

Activates the relay when the number of operations for switch maintenance, defined in topic [5.4.4.6.3](#), in the “Alarm due to number of OLTC operations” parameter, is reached.

**Adjustment range:** YES, NO.

**Default value:** NO.

### Warning for maintenance by number of operations

Defines the activation of the relay in case of advance warning for maintenance by number of OLTC operations, considering the parameter “total number of OLTC operations since the last maintenance”, the daily tap changing average and the number of days for advance warning of maintenance.

**Adjustment range:** YES, NO.

**Default value:** NO.

### Perform maintenance by I<sup>2</sup> sum

It activates the relay when the sum of the squares of the currents at the time of OLTC operation has reached the value for maintenance by switched current, defined in the parameter “Adjusting the limit for the I<sub>pu</sub><sup>2</sup> sum by the OLTC”, indicating contact wear, located in topic [5.4.4.6.2](#).

**Adjustment range:** YES, NO.

**Default value:** NO.

### Warning for maintenance by I<sup>2</sup> sum

Defines the relay actuation in the event of a warning by the value of the sum of the current switched by the OLTC squared (I<sub>pu</sub><sup>2</sup>), considering the counter “Adjusting the limit for the I<sub>pu</sub><sup>2</sup> sum by the OLTC after maintenance”, the daily average of the switched current squared and the number of days for advance notice for maintenance.

**Adjustment range:** YES, NO.

**Default value:** NO.

## Configuration of OLTC block relay mode

Activates relay when there is an OLTC blocking condition.

**Adjustment range:** Normal, inverted.

**Default value:** Normal.



## 5.5. Configuration

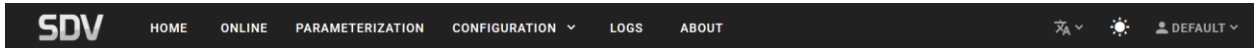

Figure 102 - Configuration Tab

The "Configuration" section contains general equipment settings, allowing the user to define essential parameters for its operation. Here, users can configure the application used, set the date and time, define network information, manage access permissions, perform firmware updates, and customize manager data. These settings ensure the system is aligned with the specific needs of each installation.

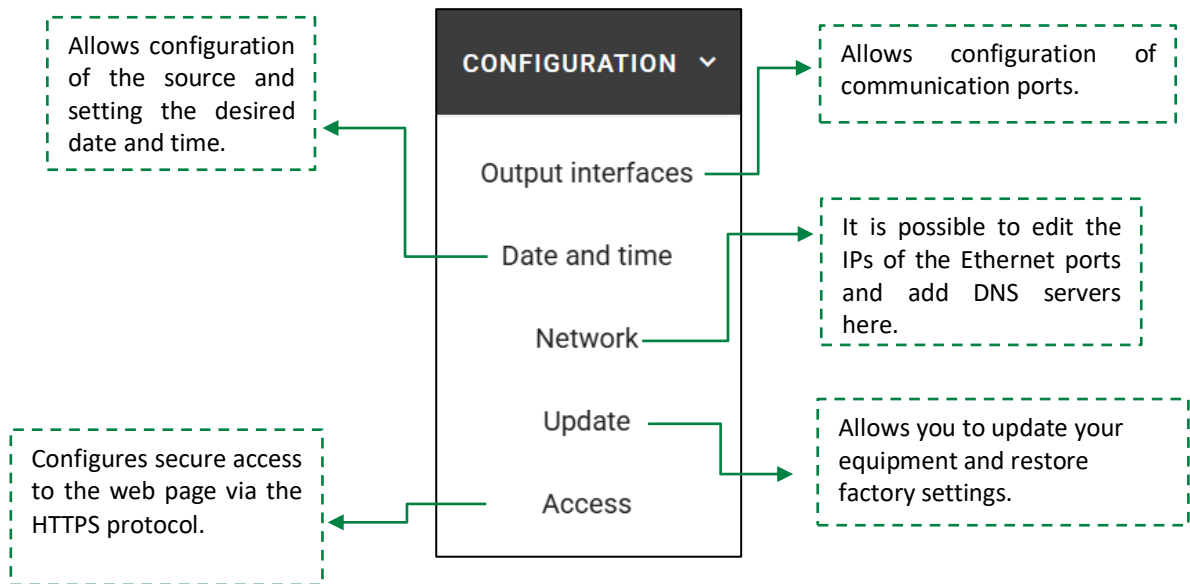

Figure 103 - Description of configurations

### 5.5.1. Output interfaces

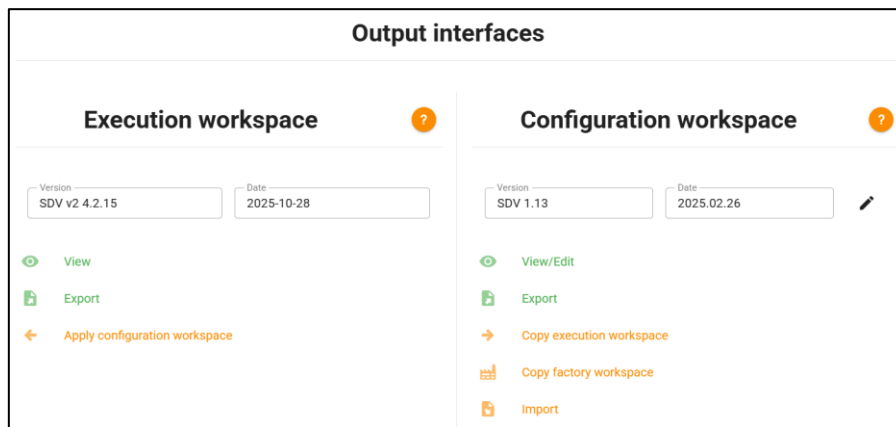

Figure 104 - Configuration section → Output Interfaces

### Running area

The running area stores the ongoing data being used by system processes. It is a non-volatile



area, but cannot be edited at runtime.

- ✓ **View:** Allows you to view the data currently running for inputs and outputs. No changes are allowed;
- ✓ **Export:** Downloads a copy of the ongoing data, in encrypted format (.back) that serves as a backup for possible updates;
- ✓ **Apply configuration area:** Applies the settings defined in the “Configuration area”.

### Configuration area

This is the area where data can be changed and edited at any time. Until this data is applied, it does not interfere with system execution.

- ✓ **View/Edit:** Allows you to view data and allow the user to make changes to the system. Any changes will only take effect after applying the modifications from the configuration area to the running area.
- ✓ **Export:** Downloads a copy of the data from the configuration area, which serves as a backup for any updates;
- ✓ **Copy running area:** Copies to the configuration being used in the running area;
- ✓ **Copy factory area:** Clears the current configuration and returns to the factory settings;
- ✓ **Import:** Allows you to import the (.back) file. For security, it is encrypted.



## 5.5.2. Configuring communication

### Configuration area

In the configuration area, click on “View/edit”, after that, click on “add”.

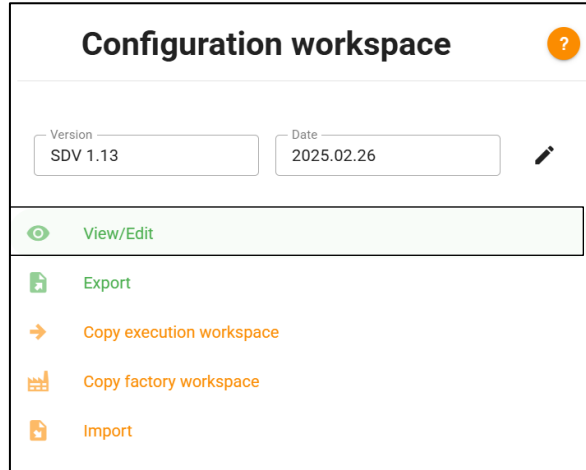

Figure 105 - Configuration area

### Configuring from output

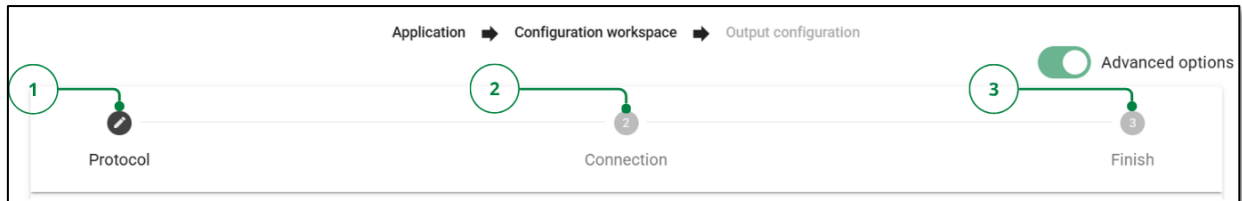

Figure 106 - Configuration from output

#### 1. Protocol selection

To start the configuration, first select one of the available protocols below:

- Modbus;
- DNP3;
- IEC;
- Other.

#### 2. Connection settings

After choosing the protocol, the next step is to adjust the connection parameters, which vary depending on the selected protocol.

#### 3. IED

Finally, select the SDV, set the name and set the address if applicable.



### 5.5.3. Network

Network settings are accessed via the Configuration section.

In it, the user can manually modify the IP address and network mask, for both the primary and secondary IP addresses. Additionally, it is possible to change the gateway address, DNS 1, and DNS 2. The equipment has two configurable operating modes: independent port mode and bridge mode.

#### 5.5.3.1. Independent ports mode

In Independent operating mode, the two network ports operate separately, allowing the user to configure distinct IP addresses for different networks.

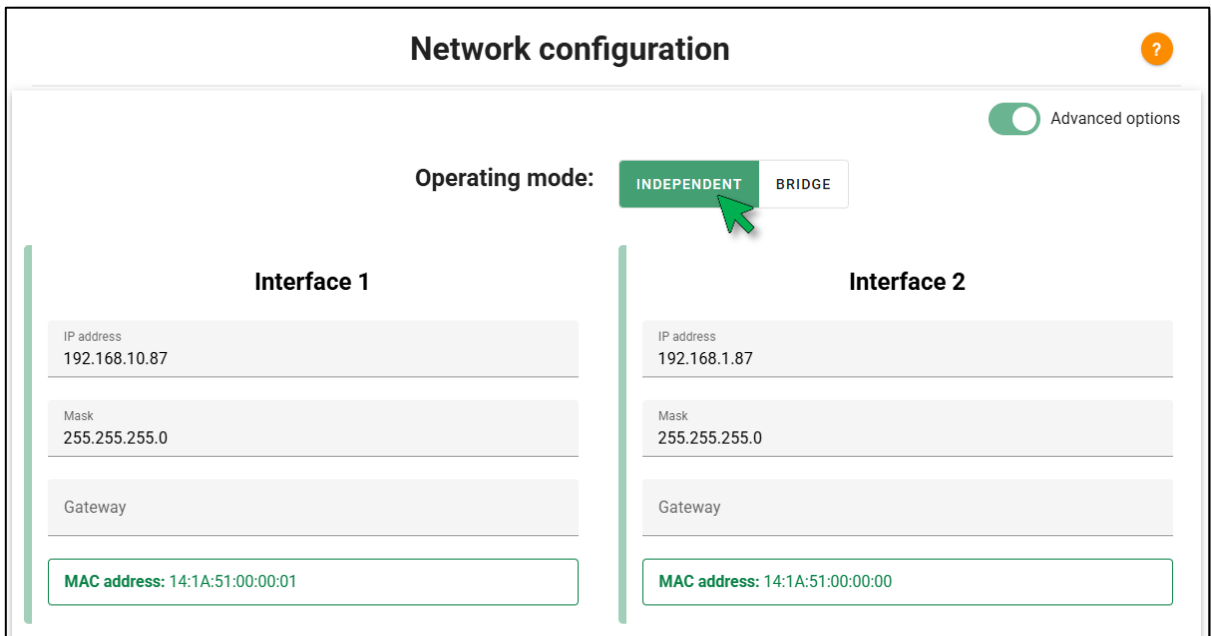

Figure 107 - Configurations → Independent ports mode

#### 5.5.3.2. Bridge port mode

In Bridge mode, the two ports act as a single network interface, functioning in interconnected mode. In this configuration, it is possible to use a single IP address for both ports.

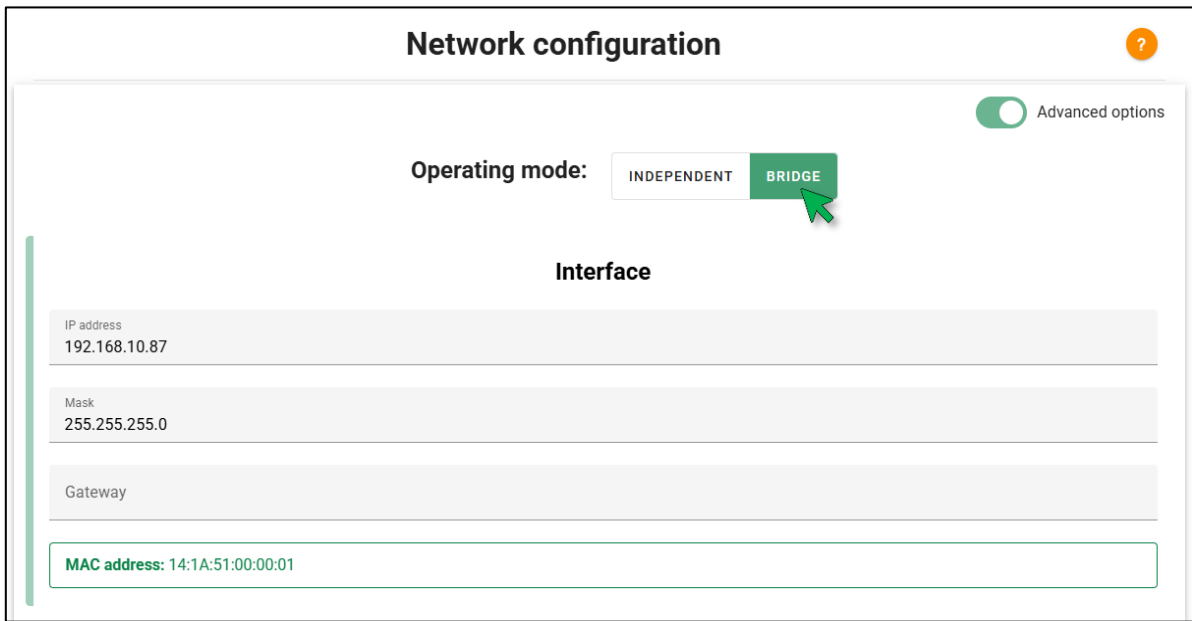

Figure 108 - Configurations → Bridge port mode

## 5.6. Logs

In the "Logs" section, configuration logs, application logs, and system logs are available for download. These logs correspond to the embedded system's internal logs and can be requested by developers or authorized technicians for diagnosis and troubleshooting purposes.

In the SDV mass logs section, it allows the user to download a text file in .csv format that represents the equipment's event history.

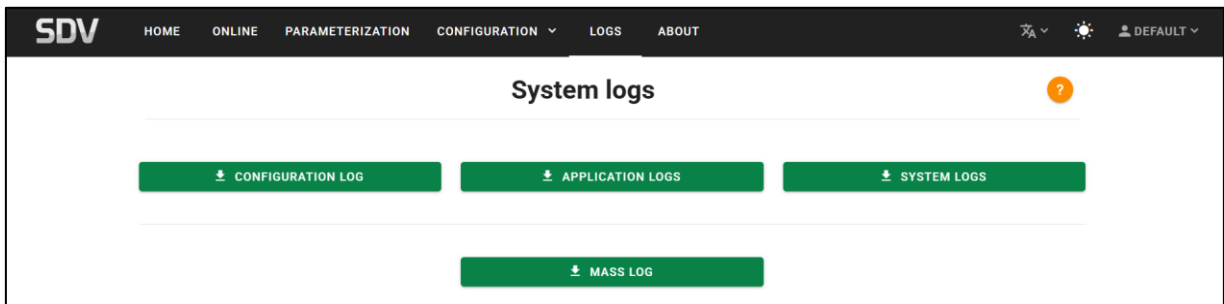

Figure 109 - System logs



## 5.7. About

This section is for consulting system information. Here, the user can find data such as the device's serial number, system version, and the installed application.

The screenshot displays the 'About' section of the SDV web interface. The top navigation bar includes 'HOME', 'ONLINE', 'PARAMETERIZATION', 'CONFIGURATION', 'LOGS', and 'ABOUT'. The main content area is divided into three sections:

- Treotech logo**
- Serial number:** 000000  
**Firmware:** V1.00 R1  
**Model:** SDV FOFO
- System**  
**Version:** 4.2.15  
**Date:** 2025-10-28  
**Kernel:** 37a24b4  
**Bootloader:** fe9e521
- Factory application**  
**Version:** SDV v2 4.2.15  
**Date:** 2025-10-28

On the right, a green banner indicates 'Application running'. Below it, the system version and date are shown: 'Version: SDV v2 4.2.15' and 'Date: 2025-10-28'. A 'More details' toggle is present. A table lists installed applications:

Position	Protocol	IED	Status
Output	dnp3	485_2_DNP3	🟢
Output	dnp3	TCP_IP_DNP3	🟢
Output	modbus	485_1_MDBUS	🟢
Output	modbus	TCP_IP_MDBUS	🟢

Figure 110 - "About" section



## 6. Troubleshooting

If you encounter difficulties or problems with the system's operation, we suggest checking the possible causes and simple solutions presented in the following sections. If this information is not sufficient to resolve the issue, please contact Treotech Customer Service or an authorized representative.

### 6.1. Self-diagnosis

The SDV features three self-diagnosis panels, each with four hexadecimal digits and capable of representing up to four different alarms. Each fault is represented by one of the following values: 1, 2, 4, and 8. The value displayed on the digit is the sum of all active alarms for that digit. If, for example, a certain digit displays the number 3, this means that alarms 1 and 2 are active ( $1 + 2 = 3$ ). If a digit displays the letter B, for example, alarms 1, 2, and 8 are currently active, since in hexadecimal numbers  $B = 1 + 2 + 8$ .



Figure 111 - Self-diagnosis indication

The tables below present all SDV self-diagnosis codes and the recommended procedures for each case.



Table 25 - Self-diagnosis panel 1

Self-diagnosis panel 1			
Code	Description	Probable cause	Recommended procedure
0001	Overflow self-diagnosis in the CT measurement of cooling group 1	Internal SDV failure or unidentified external cause.	Contact Treotech technical support.
0002	Overflow self-diagnosis in the CT measurement of cooling group 2		
0004	Overflow self-diagnosis in the CT measurement of cooling group 3		
0008	Overflow self-diagnosis in the CT measurement of cooling group 4		
0010	Self-diagnosis of potentiometric transmitter reading error	<p>The cables connecting the potentiometric transmitter to the SDV are not shielded.</p> <p>Shielding of the cables connecting the potentiometric transmitter to the SDV grounded at more than one point, not grounded or without shielding continuity along the route.</p> <p>Poor contact in the potentiometric position transmitter cursor or in the cables connecting it to the SDV.</p> <p>Connection cables from the potentiometric transmitter to the SDV with resistance greater than 8 ohms per track - very reduced gauge depending on the distance traveled.</p> <p>Connection cables from the potentiometric transmitter to the SDV with different gauges or lengths on each track.</p> <p>Self-diagnosis in parameter settings Number of taps and/or Resistance, Initial Offset, Final Offset and SDV Transition tap.</p>	<p>Replace the connection cables from the potentiometric transmitter to the SDV with shielded cables, as per the instructions in subchapter 3.3.1.5.</p> <p>Ground the shielding of the cables connecting the potentiometric transmitter to the SDV at only one point and maintain the continuity of the shielding, as per the instructions in subchapter 3.3.1.5.</p> <p>Eliminate poor contact in the cables or in the potentiometric transmitter cursor.</p> <p>Replace the connection cables from the potentiometric transmitter to the SDV with cables with an appropriate gauge, as per the instructions in subchapter 3.3.1.5.</p> <p>Replace the connection cables from the potentiometric transmitter to the SDV with shielded cables with identical gauge on all 3 wires, as per the instructions in subchapter 3.3.1.5.</p> <p>Correct the settings of the parameters Number of taps, SDV Resistance, Initial Offset, Final Offset and OLTC Transition tap, according to the instructions in subchapter 3.3.1.5.</p> <p>Replace the potentiometric transmitter step resistors with ones with an accuracy better than</p>



		The step resistors of the potentiometric transmitter have a tolerance greater than 1% of their nominal value.	or equal to 1%.
0020	Self-diagnosis of reading the channel of the potentiometric transmitter	Internal failure.	Restart the device by disconnecting the SDV from the power supply and then reconnecting it immediately. If this action has no effect or displays the same self-diagnosis after a certain period of time, contact Treotech technical support.
0040 0080	Reserved	-	-
0100	Self-diagnosis of communication error with SPS	Internal SDV failure or failure in the communication network with the SPS.	Check the entire SDV communication network with the SPS. If the problem cannot be resolved, contact Treotech technical support.
0200	Self-diagnosis of synchronization error with SPS	Failure of the SPS or in the OLTCs control circuit.	Check the OLTCs control circuit and SPS tap up/down relays. If the problem cannot be resolved, contact Treotech technical support.
0400	Self-diagnosis of SPS programming error	SPS programming failure.	Check the SPS programming on the network. If the problem cannot be resolved, contact Treotech technical support.
0800	Self-diagnosis of SPS TAP reading error	The cables connecting the potentiometric transmitters to the SPS are not shielded.  Shielding of the cables connecting the potentiometric transmitters to the SPS grounded at more than one point, not grounded or without continuity of the shielding along the route.  Poor contact in the cursor of the	Replace the potentiometric transmitter connection cables to the SPS with shielded cables.  Ground the shielding of the cables connecting the potentiometric transmitters to the SPS at only one point and maintain the continuity of the shielding.  Eliminate poor contact in the



		<p>potentiometric position transmitters or in the cables connecting them to the SPS.</p> <p>Cables connecting potentiometric transmitters to SPS with resistance greater than 8 ohms per track - very reduced gauge depending on the distance traveled.</p> <p>Cables connecting potentiometric transmitters to SPS with different gauges or lengths on each track.</p> <p>Self-diagnosis in the adjustment of the tap and/or RES parameters of the SPS.</p> <p>There are resistors in the potentiometric transmitters at the intermediate tap positions.</p> <p>The step resistors of the potentiometric transmitter have a tolerance greater than 1% of their nominal value.</p>	<p>cables or in the cursor of the potentiometric transmitters.</p> <p>Replace the cables connecting the potentiometric transmitters to the SPS with cables of appropriate gauge.</p> <p>Replace the connection cables from the potentiometric transmitter to the SDV with shielded cables with identical gauge on all 3 wires.</p> <p>Correct the tap and RES parameter settings of the SPS.</p> <p>Remove the resistors from the intermediate positions of the OLTC, replacing them with jumpers.</p> <p>Replace the potentiometric transmitter step resistors with ones with an accuracy better than or equal to 1%.</p>
1000	Reserved	-	-
2000			
4000	Self-diagnosis of 1v65 error of cooling CTs	Internal SDV failure or unidentified external cause.	Contact Treotech technical support.
8000	Self-diagnosis of communication with the control board	Internal SDV failure or unidentified external cause.	Contact Treotech technical support.

Table 26 - Self-diagnosis panel 2

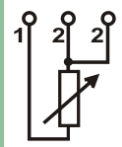
Self-diagnosis panel 2			
Code	Description	Probable cause	Recommended procedure
0001	Self-diagnosis of overflow when measuring RTD3	Internal SDV failure or unidentified external cause.	Contact Treotech technical support.
0002	Self-diagnosis of RTD1 temperature jump	<p>Poor contact or disconnection in one of the cables connected to terminals 1 or 2 of the temperature sensor.</p> 	Check for poor contacts or disconnections along the entire length of the cables connected to terminals 1 or 2 of the temperature sensor, including the connection to the SDV, the feed-through terminals and the connection to the sensor.
0004	Self-diagnosis of RTD2 temperature jump	Using unshielded cable to connect the Pt100 sensor to the SDV.	Check if shielded cable is being used to connect the temperature sensor to the SDV.



		<p>Shields of the cables connecting the SDV to the Pt100 sensor are not grounded or are grounded in more than one place.</p> <p>Internal temperature sensor failure.</p>	<p>Check that the shielding of the cable connecting the SDV to the temperature sensor is grounded only on one side of the connection and the other end is insulated.</p> <p>Replace the defective temperature sensor.</p>
<b>0008</b>	Self-diagnosis of RTD3 temperature jump	<p>Using unshielded cable to connect the Pt100 sensor to the SDV.</p> <p>Shields of the cables connecting the SDV to the Pt100 sensor are not grounded or are grounded in more than one place.</p> <p>Internal temperature sensor failure.</p>	<p>Check if shielded cable is being used to connect the temperature sensor to the SDV.</p> <p>Check that the shielding of the cable connecting the SDV to the temperature sensor is grounded only on one side of the connection and the other end is insulated.</p> <p>Replace the defective temperature sensor.</p>
<b>0010</b>	Self-diagnosis of overflow when measuring oil temperature	<p>Internal SDV failure or unidentified external cause.</p>	<p>Contact Treotech technical support.</p>
<b>0020</b>	Self-diagnosis of overflow when measuring the temperature of winding 1		
<b>0040</b>	Self-diagnosis of overflow when measuring the temperature of winding 2		
<b>0080</b>	Self-diagnosis of overflow when measuring the temperature of winding 3		
<b>0100</b>	Self-diagnosis of overflow in the CT1 measurement		
<b>0200</b>	Self-diagnosis of overflow in the CT2 measurement		
<b>0400</b>	Self-diagnosis of overflow in the CT3 measurement		
<b>0800</b>	Self-diagnosis of overflow in the PT measurement		



1000	Self-diagnosis of CT measurement error of cooling group 1	Internal SDV failure or unidentified external cause.	Contact Treetech technical support.
2000	Self-diagnosis of CT measurement error of cooling group 2		
4000	Self-diagnosis of CT measurement error of cooling group 3		
8000	Self-diagnosis of CT measurement error of cooling group 4		

Table 27 - Self-diagnosis panel 3

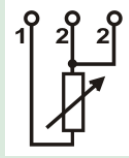
Self-diagnosis panel 3			
Code	Description	Probable cause	Recommended procedure
0001	Self-diagnosis of parameterization	Falha interna ao SDV ou causa externa não identificada.	Contact Treetech technical support.
0002	Self-diagnosis in the RTD measurement circuit	Falha interna ao SDV ou causa externa não identificada.	Contact Treetech technical support.
0004	Self-diagnosis of high temperature differential between redundant oil sensors	<p>Poor contact or disconnection in one of the cables connected to terminals 1 or 2 of the temperature sensor.</p>  <p>Using unshielded cable to connect the Pt100 sensor to the SDV.</p> <p>Redundant top oil temperature measurement is programmed in the “Select redundant sensor for oil temperature” parameter, but only one sensor is being used for the top oil.</p> <p>“Maximum temperature difference between redundant sensors” parameter programmed with a very low value.</p> <p>Shields of the cables connecting the SDV to the Pt100 sensor are not grounded or are grounded in more than one place.</p>	<p>Check for poor contacts or disconnections along the entire length of the cables connected to terminals 1 or 2 of the temperature sensors, including the connection to the SDV, the feed-through terminals and the connection to the sensors.</p> <p>Check if shielded cable is being used to connect the temperature sensors to the SDV.</p> <p>Correct the programming of the “Select redundant sensor for oil temperature” parameter according to the configuration actually used for the temperature sensors.</p> <p>Correct the programming of the “Maximum temperature difference between redundant sensors” parameter, so that it is not less than the normal temperature difference between the redundant sensors at the top of the oil selected in the “Enable temperature sensor ‘x’” parameters.</p> <p>Check that the shielding of the cable connecting the SDV to the temperature sensor is grounded</p>

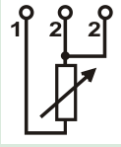
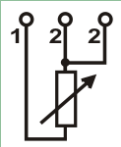
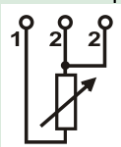

		Internal temperature sensor failure.	only on one side of the connection and the other end is insulated.  Replace the defective temperature sensor.
0008	Self-diagnosis of 1v65 voltage	Internal failure	Contact Treetech technical support.
0010	Self-diagnosis reading on Pt100 (RTD1)	Poor contact or disconnection in the cable connected to terminal 1 of the temperature sensor.	Check for poor contacts or disconnections along the entire length of the cable connected to terminal 1 of the temperature sensor, including the connection to the SDV, the feed-through terminals and the connection to the sensor.  Check if shielded cable is being used to connect the temperature sensor to the SDV.  Check that the shielding of the cable connecting the SDV to the temperature sensor is grounded only on one side of the connection and the other end is insulated.  Disable measurement of unused sensors by changing the "Enable temperature sensor 'x'" parameter.  Replace the defective temperature sensor.
0020	Self-diagnosis reading on Pt100 (RTD2)		
0040	Self-diagnosis reading on Pt100 (RTD3)	 <p>Using unshielded cable to connect the Pt100 sensor to the SDV.</p> <p>Shields of the cables connecting the SDV to the Pt100 sensor are not grounded or are grounded in more than one place.</p> <p>The sensor is not in use, but its measurement is enabled in the "Enable temperature sensor 'x'" parameters.</p> <p>Internal temperature sensor failure.</p>	
0080	Self-diagnosis of calibration on Pt100 (RTD1)	 <p>Poor contact or disconnection in the cable connected to terminals 2 of the temperature sensor.</p> <p>Using unshielded cable to connect the Pt100 sensor to the SDV.</p>	Check for poor contacts or disconnections along the entire length of the cables connected to terminals 2 of the temperature sensor, including the connection to the SDV, the feed-through terminals and the connection to the sensor.  Check if shielded cable is being used to connect the temperature sensor to the SDV.
0100	Self-diagnosis of calibration on Pt100 (RTD2)	 <p>Poor contact or disconnection in the cable connected to terminal 2 of the temperature sensor.</p> <p>Using unshielded cable to connect the Pt100 sensor to the</p>	Check for poor contacts or disconnections along the entire length of the cables connected to terminals 2 of the temperature sensor, including the connection to the SDV, the feed-through terminals and the connection to the sensor.  Check if shielded cable is being

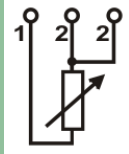

		<p>SDV.</p> <p>Shields of the cables connecting the SDV to the Pt100 sensor are not grounded or are grounded in more than one place.</p> <p>The sensor is not in use, but its measurement is enabled in the “Enable temperature sensor ‘x’” parameters.</p> <p>Internal temperature sensor failure.</p>	<p>used to connect the temperature sensor to the SDV.</p> <p>Check that the shielding of the cable connecting the SDV to the temperature sensor is grounded only on one side of the connection and the other end is insulated.</p> <p>Disable measurement of unused sensors by changing the “Enable temperature sensor ‘x’” parameter.</p> <p>Replace the defective temperature sensor.</p>
<b>0200</b>	Self-diagnosis of calibration on Pt100 (RTD3)	<p>Poor contact or disconnection in the cable connected to terminal 2 of the temperature sensor.</p>  <p>Using unshielded cable to connect the Pt100 sensor to the SDV.</p> <p>Shields of the cables connecting the SDV to the Pt100 sensor are not grounded or are grounded in more than one place.</p> <p>The sensor is not in use, but its measurement is enabled in the “Enable temperature sensor ‘x’” parameters.</p> <p>Internal temperature sensor failure.</p>	<p>Check for poor contacts or disconnections along the entire length of the cables connected to terminals 2 of the temperature sensor, including the connection to the SDV, the feed-through terminals and the connection to the sensor.</p> <p>Check if shielded cable is being used to connect the temperature sensor to the SDV.</p> <p>Check that the shielding of the cable connecting the SDV to the temperature sensor is grounded only on one side of the connection and the other end is insulated.</p> <p>Disable measurement of unused sensors by changing the “Enable temperature sensor ‘x’” parameter.</p> <p>Replace the defective temperature sensor.</p>
<b>0400</b>	Self-diagnosis of TP measurement error	Internal SDV failure or unidentified external cause.	Contact Treotech technical support.
<b>0800</b>	Self-diagnosis of CT1 measurement error	Internal SDV failure or unidentified external cause.	Contact Treotech technical support.
<b>1000</b>	Self-diagnosis of CT2 measurement error	Internal SDV failure or unidentified external cause.	Contact Treotech technical support.
<b>2000</b>	Self-diagnosis of CT3 measurement error	Internal SDV failure or unidentified external cause.	Contact Treotech technical support.
<b>4000</b>	Self-diagnosis of overflow in the RTD1 measurement	Internal SDV failure or unidentified external cause.	Contact Treotech technical support.
<b>8000</b>	Self-diagnosis of overflow in the RTD2 measurement		



## 6.2. Alarms

For alarms, the SDV also features three panels, each with four hexadecimal digits and capable of representing up to four different alarms. Each alarm is represented by one of the following values: 1, 2, 4, and 8. The value displayed on the digit will be the sum of all active alarms for that digit. If, for example, a certain digit displays the number 3, this means that alarms 1 and 2 are active (1 + 2 = 3). If a digit displays the letter B, for example, alarms 1, 2, and 8 are currently active, since in hexadecimal numbers B = 1 + 2 + 8.



Figure 112 - Alarms

Table 28 - Alarm panel 1

Alarm panel 1	
Code	Alarm Description
0001	Alarm due to high loss of life of winding 1.
0002	Alarm due to high loss of life of winding 2.
0004	Alarm due to high loss of life of winding 3.
0008	Alarm due to overvoltage.
0010	Alarm due to overcurrent.
0020	Alarm due to undervoltage.
0040	Alarm due to OLTC blocking.
0080	Alarm due to OLTC check.
0100	Alarm due to maintenance warning for high number of tap changes
0200	Alarm due to maintenance warning for high switched current
0400	Alarm due to maintenance for high number of tap changes
0800	Alarm due to maintenance for high switched current
1000	Alarm due to high transmitter cursor voltage
2000	Reserved
4000	Reserved
8000	Reserved



Table 29 - Alarm panel 2

Alarm panel 2	
Code	Alarm Description
0001	Alarm due to improper activity of cooling group 1
0002	Alarm due to high current of cooling group 2
0004	Alarm due to low current of cooling group 2
0008	Alarm due to improper activity of cooling group 2
0010	Alarm due to high current of cooling group 3
0020	Alarm due to low current of cooling group 3
0040	Alarm due to improper activity of cooling group 3
0080	Alarm due to high current of cooling group 4
0100	Alarm due to low current of cooling group 4
0200	Alarm due to improper activity of cooling group 4
0400	Alarm due to low useful life of winding 1
0800	Alarm due to low useful life of winding 2
1000	Alarm due to low useful life of winding 3
2000	Alarm due to low lifetime of winding 1
4000	Alarm due to low lifetime of winding 2
8000	Alarm due to low lifetime of winding 3

Table 30 - Alarm panel 3

Alarm panel 3	
Code	Alarm Description
0001	Alarm due to high oil temperature
0002	Alarm due to high temperature of winding 1
0004	Alarm due to high temperature of winding 2
0008	Alarm due to high temperature of winding 3
0010	Alarm due to oil shutdown temperature
0020	Alarm due to winding 1 shutdown temperature
0040	Alarm due to winding 2 shutdown temperature
0080	Alarm due to winding 3 shutdown temperature
0100	Alarm due to oil temperature shutdown timing
0200	Alarm due to winding 1 temperature shutdown timing
0400	Alarm due to winding 2 temperature shutdown timing
0800	Alarm due to winding 3 temperature shutdown timing
1000	Alarm due to high instantaneous temperature differential
2000	Alarm due to high filtered temperature differential
4000	Alarm due to high current of cooling group 1
8000	Alarm due to low current of cooling group 1



### 6.3. Alarm memories and self-diagnosis

To check which alarms and self-diagnoses have occurred recently, simply consult their respective memories. To do this, press the and keys sequentially. To navigate between screens, use the and keys. To clear (reset) the alarm or self-diagnosis memories, access the corresponding screen and hold the key for 5 seconds.



Figure 113 - Alarm memory and self-diagnosis



## 7. Commissioning for entry into service

After installing the equipment, commissioning must follow the basic steps below.

### 7.1. General commissioning guidelines

- ✓ Before energizing the transformer, check that the current transformer (CT) circuits are correctly connected to the SDV input, ensuring that no CT is open;
- ✓ Check the mechanical and electrical installations according to the recommendations in [chapter 3](#) of this manual. Also check that the electrical connections are correct (e.g., by performing continuity tests);
- ✓ Perform all SDV parameterization according to the instructions in [chapter 5](#) of this manual;
- ✓ If dielectric strength tests are performed on the wiring (applied voltage), disconnect the cables connected to the SDV's ground terminal to avoid destroying the surge protection devices inside the equipment. These protection devices are internally connected between the input/output terminals and ground, clamping the voltage at approximately 300 V. Applying high voltages for a long period of time (e.g., 2 kV for 1 minute) would destroy these protection devices;
- ✓ Reconnect the ground cables to the SDV terminals if they were disconnected for applied voltage testing;
- ✓ Power the SDV with any voltage in the range of 85 to 265 V AC/DC, 50/60 Hz;
- ✓ Verify that the current loop output displays the correct value in relation to the associated variable;
- ✓ Using a continuity indicator, test the alarm contacts. The contacts can be forced to close and open by changing their operating mode from NO to NC and vice versa;
- ✓ Using a suitable computer, communication converter and software, as applicable, check the operation of the SDV's RS-485 port.

### 7.2. Commissioning guidelines for regulation functionality

- ✓ Disable commands to the on-load tap changer or select the tap changer for local command before energizing the SDV;
- ✓ Verify that the SDV voltage, current, and power factor measurements are correct and test the actuation of the dry contact inputs;
- ✓ If possible, use variable AC voltage and current sources to vary these quantities at the SDV input. Verify that the results match on the display;
- ✓ Check the operation of the contacts for voltage raising and lowering, the operation of the various alarms (U<, U>, I>) and the blocking of the OLTC;



- ✓ Normalize commands for OLTC.

### 7.3. Commissioning guidelines for temperature functionality

- ✓ Ensure that no contact operations will interact with other systems during this phase. If necessary, isolate all control, alarm, and shutdown contacts;
- ✓ Connect a temperature calibrator, resistive decade or check the temperature of the Pt100 connected to each SDV measurement input, checking if the measurements are correct;
- ✓ Inject AC current into the SDV current measurement inputs, checking that the indications are correct on the equipment query screens;
- ✓ Using a continuity tester, test the operation of the alarm, shutdown, and forced cooling contacts. Contact operation can be forced, for example, by reducing their settings to values lower than the current readings;
- ✓ Reconnect any contacts that may have been isolated.



## 8. Technical data and type tests

### 8.1. Technical data

Table 31 - Technical data

Hardware	Range/Description
Supply voltage Tension d'alimentation	85...250 Vac/Vdc, 50/60 Hz
Maximum consumption Consommation maximale	< 12 W
Operating temperature Température de fonctionnement	-40... 85°C
Degree of protection Degré de protection	IP20
Case material Matériau du boîtier	Aluminum
Fixing Fixation	DIN Rail or Panel Rail DIN ou Panneau
Humidity Humidité	5% to 90% humidity without condensation 5 % à 90 % sans condensation
Altitude	1000 meters 1000 mètres
Degree of pollution Degré de pollution	II
Overvoltage category Catégorie de surtension	II
Open equipment Équipement ouvert	✓
Cabling Câblage	<ul style="list-style-type: none"> <li>Wire Gauge: 12 to 30 AWG / 0.2 - 2.5 mm<sup>2</sup> Calibre du fil: 12 à 30 AWG / 0.2 - 2.5 mm<sup>2</sup></li> <li>Tightening Torque (Fixing): 0.2 to 0.25 Nm Couple de serrage (fixation): 0.2 à 0.25 Nm</li> <li>Tightening Torque (Wire): 0.4 to 0.5 Nm Couple de serrage (Fil): 0.4 à 0.5 Nm</li> <li>Material: Copper Matériau: Cuivre</li> <li>Compliance: UL508 – for use with cables rated for 60/75°C wire only Conformité: pour utilisation avec câbles certifiés 60/75 °C uniquement</li> </ul>
<b>Measurement inputs / Entrées de Mesure</b>	
1x Voltage measurement (PT) 1x Mesure de tension (TP)	0...185 Vrms
1x Potentiometric transmitter 1x Transmetteur potentiométrique	2 a 50 (Until 960 Ω) 2 à 50 (Jusqu'à 960 Ω)
3x Current CTs (1 regulation + 2 for thermal imaging) 3x TC de courant (1 régulation + 2 pour image thermique)	External CT 0...10 Aca rms TC externe 0...10 Aca rms
3x RTDs 3x RTD (Sondes de température)	Pt100 Ω at 0 °C 3-wire, range: -55...200 °C Pt100 Ω à 0 °C, 3 fils, plage : -55...200 °C
4x Ventilation CTs 4x TC de ventilation	External CT 0...10 Aca rms TC externe 0...10 Aca rms



1x BCD 1x BCD	7 dry contact inputs 7 entrées à contact sec
6x Wet contacts 6x Contacts polarisés	Maximum input voltage: 250 Vac/Vdc Tension d'entrée maximale : 250 Vac/Vdc
<b>Outputs / Sorties</b>	
1x OLTC Relay 1x Relais OLTC (Régleur en charge)	<ul style="list-style-type: none"> <li>• NO (Normally Open) contacts Contacts NO (Normalement Ouvert)</li> <li>• Dielectric Strength: 4000 Vac Rigidité diélectrique : 4000 Vac 5 A at 125 VAC (NA) 5 A at 250 VAC (NA) 5 A at 30 VDC (NA)</li> </ul>
1x Self-diagnosis relay 1x Relais d'autodiagnostic	<ul style="list-style-type: none"> <li>• NC (Normally Closed) contacts Contacts NC (Normalement Fermé)</li> <li>• Dielectric Strength: 4000 Vrms Rigidité diélectrique : 4000 Vrms 3 A at 125 VAC (NF) 3 A at 250 VAC (NF) 3 A at 30 VDC (NF)</li> </ul>
4x Ventilation relays 4x Relais de ventilation	<ul style="list-style-type: none"> <li>• NC (Normally Closed) contacts NC (Normalement Fermé)</li> <li>• Dielectric Strength: 4000 Vrms Rigidité diélectrique : 4000 Vrms 3 A at 125 VAC (NF) 3 A at 250 VAC (NF) 3 A at 30 VDC (NF)</li> </ul>
11x Signaling relays and commands for switch or TRIP 11x Relais de signalisation et commandes (Déclenchement/TRIP)	<ul style="list-style-type: none"> <li>• NO (Normally Open) contacts NO (Normalement Ouvert)</li> <li>• Dielectric Strength: 4000 Vac Rigidité diélectrique : 4000 Vrms 5 A at 125 VAC (NA) 5 A at 250 VAC (NA) 5 A at 30 VDC (NA)</li> </ul>
<b>Network interfaces / Interfaces réseau</b>	
Serial communication ports Ports de communication série	2 RS-485 (TIA-485-A), 1 RS-485 (TIA-485-A) or 1 RS-232 (TIA-232-F)
IEEE 802.3 (10/100 Mbps) communication ports <sup>1</sup> Ports de communication Ethernet (IEEE 802.3)	<p>Available in the following models: RJ45: 2 RJ45 Ethernet (10/100BASE-T); FOFO: 2 Fiber Optic Ethernet (10/100BASE-FX; MM 1310nm SC connector) (UL certified); FOSR: 1 Fiber Optic Ethernet (10/100BASE-FX; MM 1310nm SC connector) + 1 Serial Fiber Optic (MM 850nm SC connector).</p> <p>RJ45: 2x RJ45 Ethernet (10/100BASE-T) FOFO: 2x Ethernet Fibre Optique (10/100BASE-FX ;</p>



	MM 1310nm, connecteur SC) FOSR: 1x Ethernet Fibre Optique + 1x Série Fibre Optique (MM 850nm, connecteur SC)
Service port (parameterization) Port de service (Paramétrage)	RJ45: 1 Ethernet RJ45 (10/100BASE-T) 1x Ethernet RJ45 (10/100BASE-T)
Master/Client protocols Protocoles Maître/Client	Modbus® (RTU and TCP) and DNP3 (RTU e TCP) Modbus® (RTU et TCP) et DNP3 (RTU et TCP)
Slave/Server protocols Protocoles Esclave/Serveur	Modbus® (RTU and TCP) and DNP3 (RTU e TCP) IEC 61850 (MMS server / GOOSE Publisher) <sup>2</sup> Modbus®, DNP3, IEC 61850 (Serveur MMS / Éditeur GOOSE)
<b>Dimensions and weight / Dimensions et poids</b>	
Dimension Dimensions	131mm x 134mm x 156mm
Weight Poids	1.200 kg 1,200 kg



## 8.2. Type tests

Table 32 - Type tests

<b>Immunity to high-energy surges (IEC 60255-26:2023)</b>	
Differential mode	2 kV (+/-)
Common mode	4 kV (+/-)
<b>Immunity to electrical transients (1 Mhz Burst, IEC 60255-26:2023)</b>	
Peak value 1st cycle	2.5 kV (common mode), 1 kV (dif. mode)
Frequency	1 MHz
Repetition rate	200 bursts/s
<b>Applied voltage (IEC 60255-26:2023)</b>	
Dielectric strength	2 kV at 60 Hz for 1 minute
Voltage impulse	5 kV (+/-)
<b>Immunity to radiated electromagnetic fields (IEC 60255-26:2023)</b>	
Frequency	80...2500 Mhz
Modulation index	80% and 1 kHz sinusoidal
Field intensity	10 V/m
Power supply	220 V / 60 Hz
<b>Immunity to conducted electromagnetic disturbances (IEC 60255-26:2023)</b>	
Field intensity	10 Vrms
Frequency	0.15 a 80 MHz
Modulation index	80% and 1 kHz sinusoidal
Scan frequency	150 kHz to 80 MHz
Fixed frequencies	27
Duration	20 s
Power supply	220 V / 60 Hz
<b>Immunity to industrial frequency magnetic fields (IEC 61000-4-8)</b>	
Magnetic field intensity and direction	30 A/m 3 orthogonal axes
<b>Electrostatic discharges (IEC 60255-26:2023)</b>	
Air discharge	15 kV
Contact discharge	220 V / 60 Hz
<b>Immunity to fast electrical transients (IEC 60255-26:2023)</b>	
Power, inputs and outputs (Class A)	4 kV (+/-)
Current output	2 kV (+/-)
<b>Conducted emission (IEC 60255-26:2023)</b>	
Conducted emission limits (Class A)	79 dB (uV) @ 150 kHz...500 kHz (QP) 73 dB (uV) @ 500 kHz...30 MHz (QP) 66 dB (uV) @ 150 kHz...500 kHz (AV) 60 dB (uV) @ 500 kHz...30 MHz (AV)
<b>Radiated emission (IEC 60255-25)</b>	
Radiated emission limits (Class B)	50 dB (uV/m) @ 30 MHz...230 MHz (QP) 57 DB (uV/m) @ 230 MHz...1 GHz (QP)
<b>Power failure (IEC 61000-4-11)</b>	
Amplitude variation	0...80% amplitude
Affected cycles	½...300 cycles
Power supply	85 V...265 V - 50/60 Hz
Short interruptions	5 seconds 85 V and 265 V 50/60 Hz
<b>Cold tolerance (IEC 60068-2-1)</b>	
Temperature	-40°C
Test time	16 hours
<b>Dry heat tolerance (IEC 60068-2-2)</b>	



Temperature	+85 °C
Test time	16 hours
<b>Humid heat tolerance (IEC 60068-2-78)</b>	
Temperature and relative humidity	+40 °C...85% UR
Test time	24 hours
<b>Thermal cycle (IEC 60068-2-14)</b>	
Temperature range	-40...85 °C
Total test time	120 hours
<b>Response to vibration (IEC 60255-21-1)</b>	
Application mode	Sinusoidal
Amplitude and frequency range	0.075 mm (10...59 Hz) 1 G (59...150 Hz)
Duration	8 min/eixo
<b>Vibration durability (IEC 60255-21-1)</b>	
Application mode	Senoidal
Amplitude and frequency range	2G (10...150 Hz)
Duration	160 min/axis



## 9. Order specification

In the SDV purchase order, the following items must be specified:

### 1. Product name

- Smart Device for Voltage Regulation - SDV.

### 2. Quantity

- Number of units

### 3. Model

Choose one of the following options:

- SDV FOFO: 2 Fiber Optic Ethernet (UL Certified);
- SDV FOSR: 1 Ethernet optical fiber + 1 serial optical fiber;
- SDV RJ45: 2 Ethernet RJ45.



**Treetech<sup>®</sup>**

Treetech Tecnologia  
Rua José Alvim, 112, Centro  
CEP 12940-750 - Atibaia/SP  
+ 55 11 2410-1190  
[www.treetech.com.br](http://www.treetech.com.br)